

PHAsisROBy AI DRIVEN NDT

mobile automated spot weld inspection

What is PHAsisROBy?

- A complete fully autonomous mobile automated NDT ultrasonics inspection system
- Built for speed, clarity, and user delight
- Based on PHAsis BLU and the new software platform PHAsis KAI
- Infused with AI at multiple levels from experiment design to signal processing for better efficiency and precision
- Running with a robot in full collaboration mode

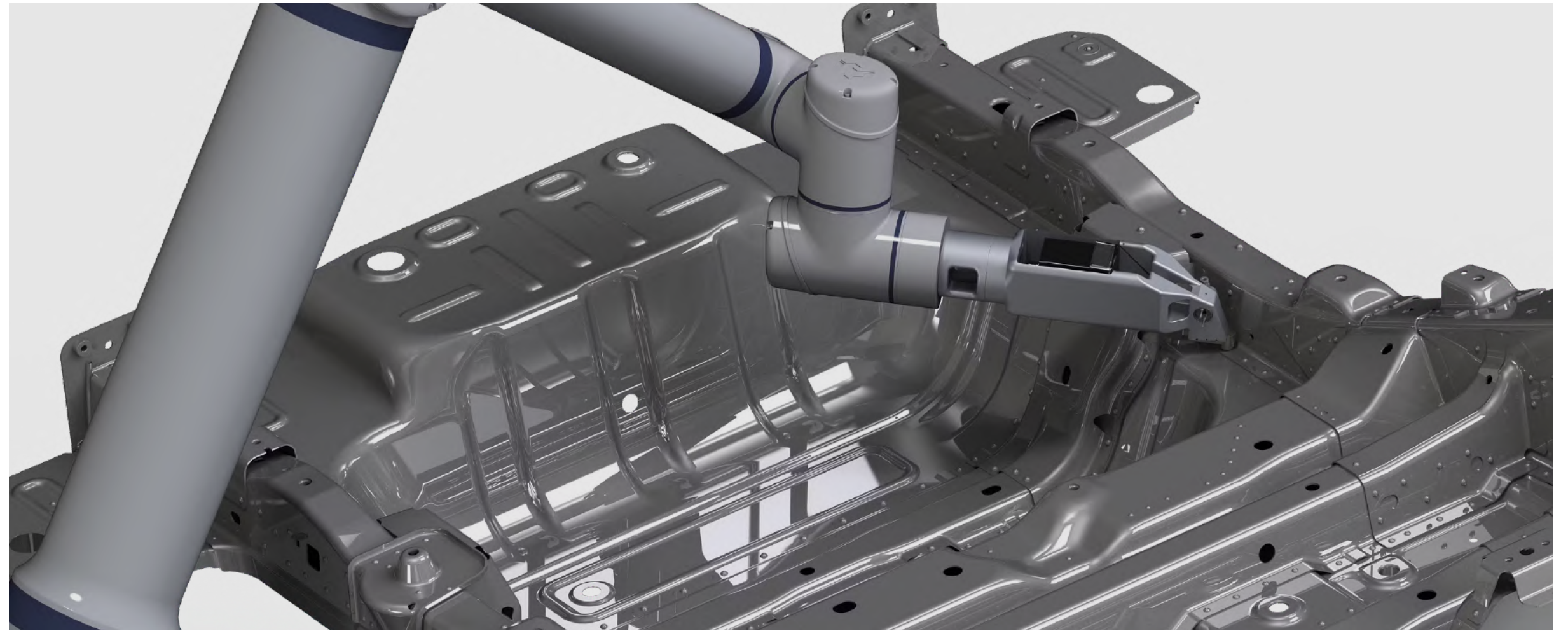

Our concept and vision

Multi-modular system for manual inspection workplaces

A future-proof solution for better and faster testing, efficient processes, and relief for employees.

- Robot brand selectable
- Modular architecture, built to evolve
- Modern architecture both hard- and software side
- Easy to use and install - complete system or partly

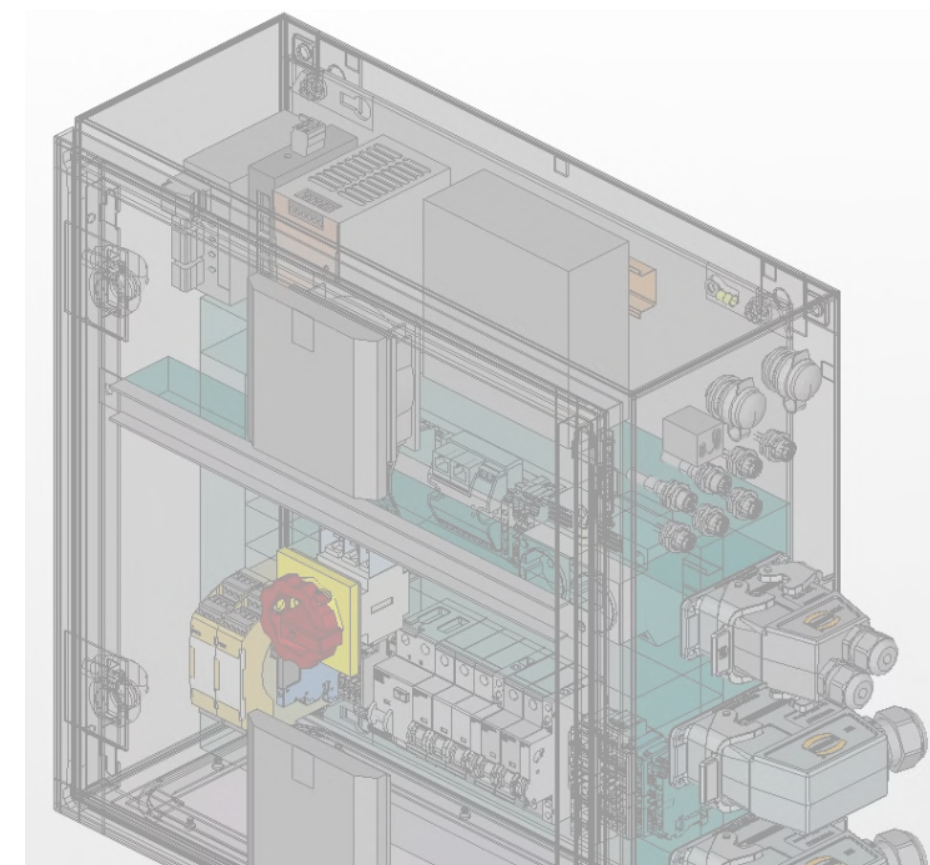
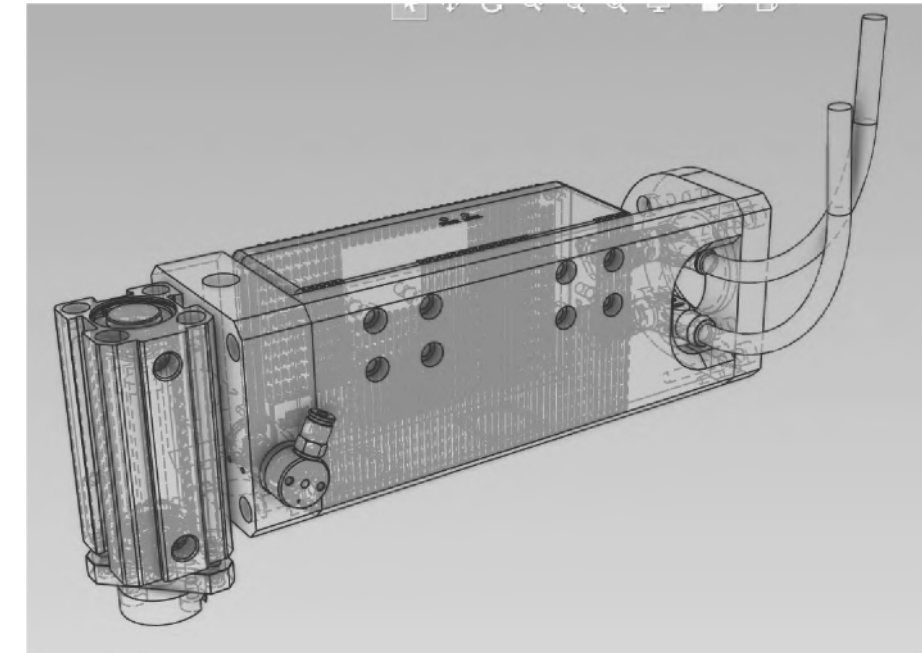
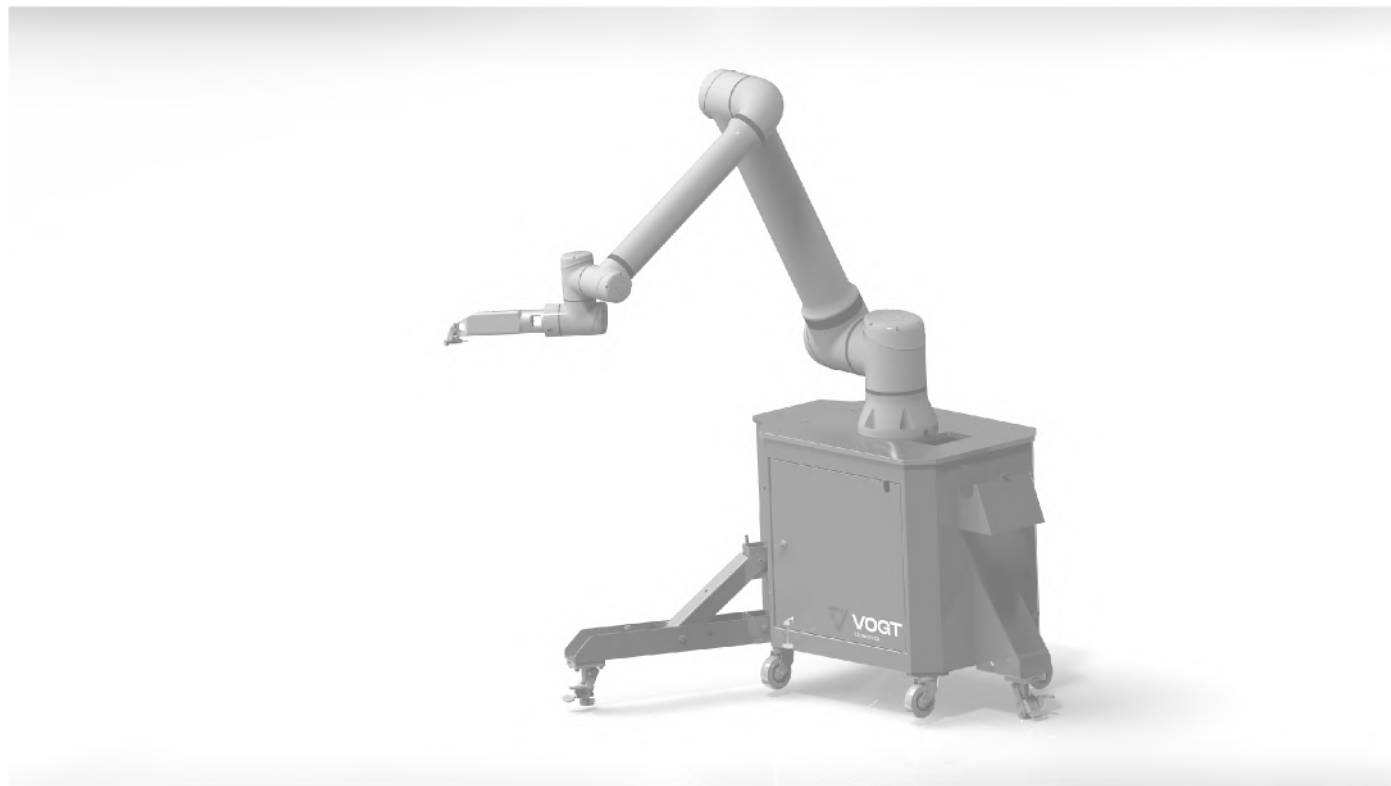

Inspiring - all robots, modular functional set, no limits

- Multi-modular kit with open API for collaborative robots
- All cobot brands, all models
- **Accelerate** – reduce inspection time significantly
- **Unify** – one phased array NDT inspection solution
- **Delight** – create a system customer love to use

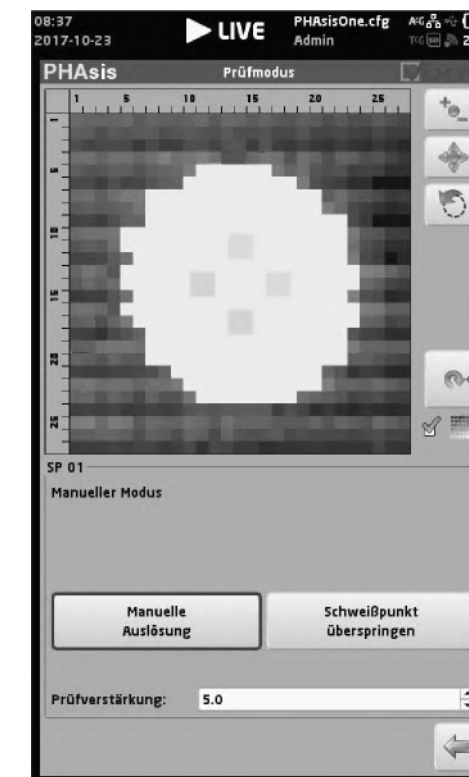
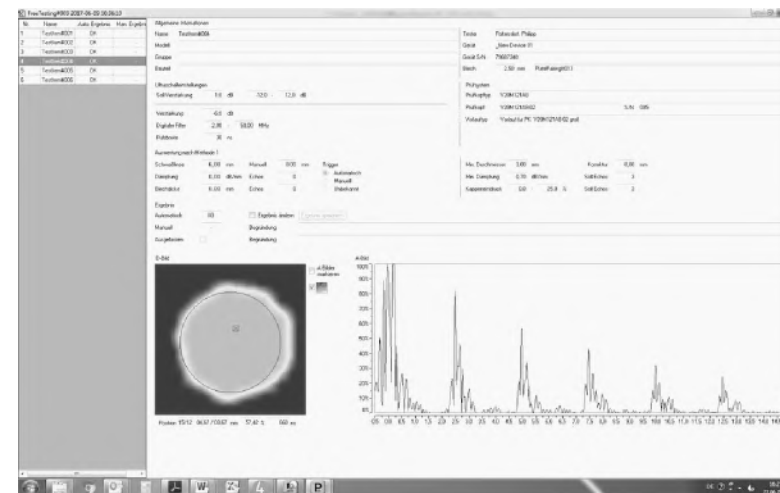

AI driven mobile automation solution for maximum efficiency

0 1

The future is automation - no doubt

The existing manual inspections are human resources intensive and needed to be automated

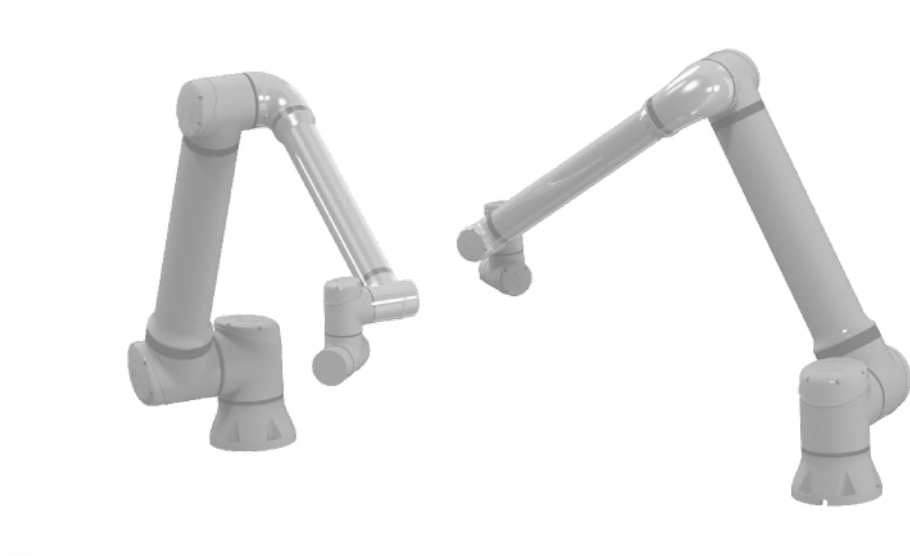

0 2

Meet modern expectations - created for operators

Better precision - more performance - faster inspections with collaborative robots

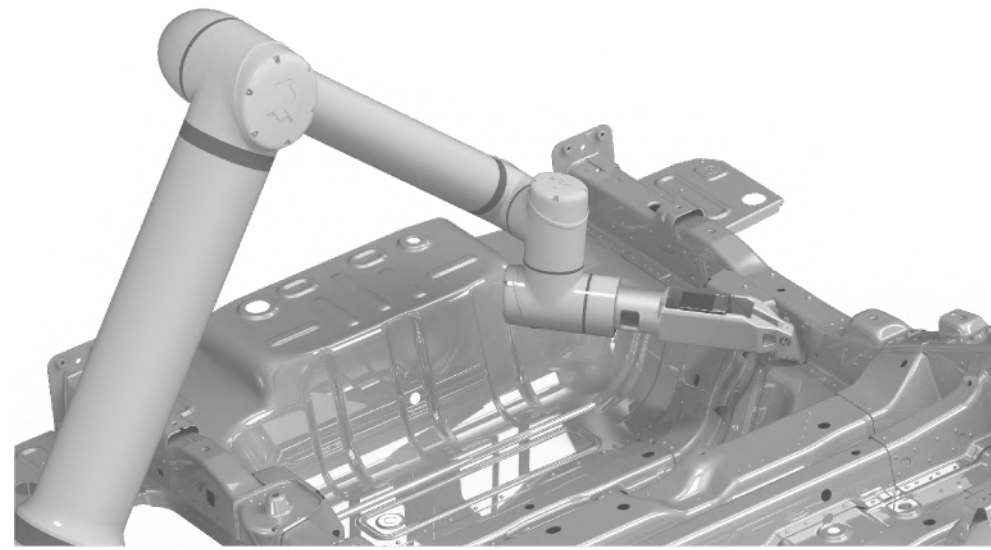

0 3

Mobile robot base KURT™

full flexible on wheels - stabile positioned on 3 legs™



All you need to have - the components

0 4

AI driven vision system for easiest usability **"Hawk"**

AI helps to identify any position (system, component, spot weld, probe adjustment), as well as obstacles (burrs, splatters) around the spot weld.

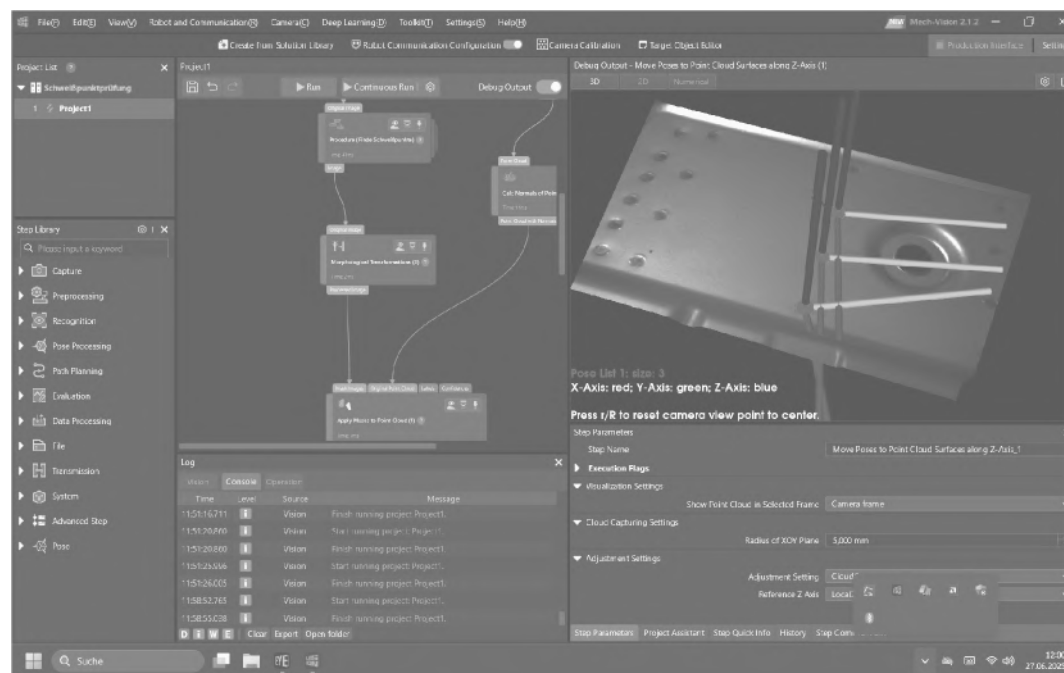

0 5

Easy to use control system **"Octopus"**

Automation and robotics nowadays are not complicated to use anymore

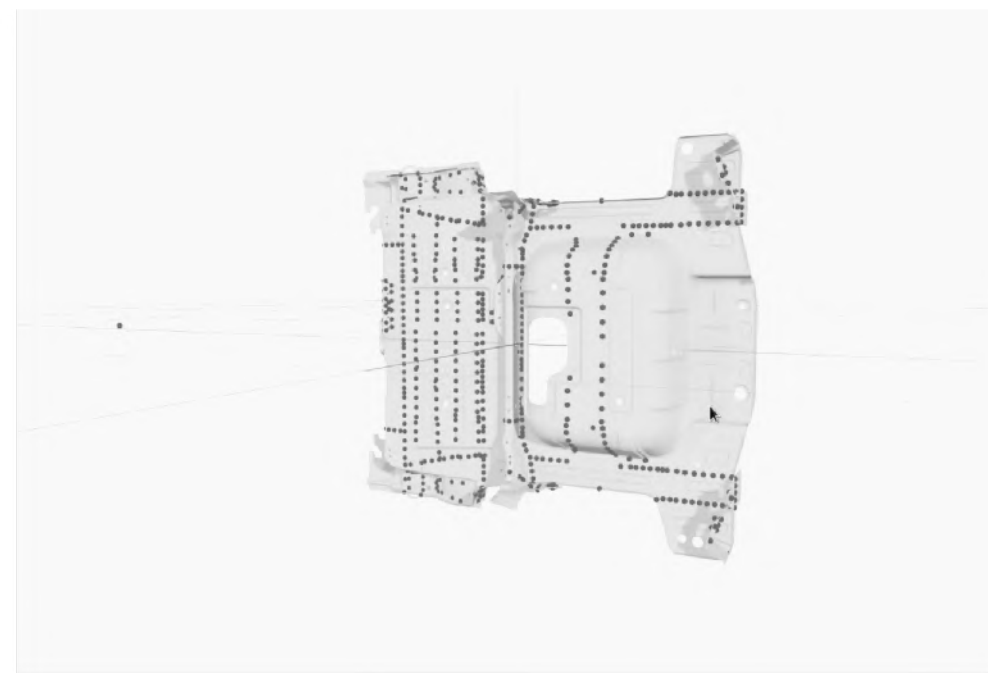

0 6

AI driven* Ultrasonic system **"PHAsis BLU"**

Phased array inspection technology for highest precision

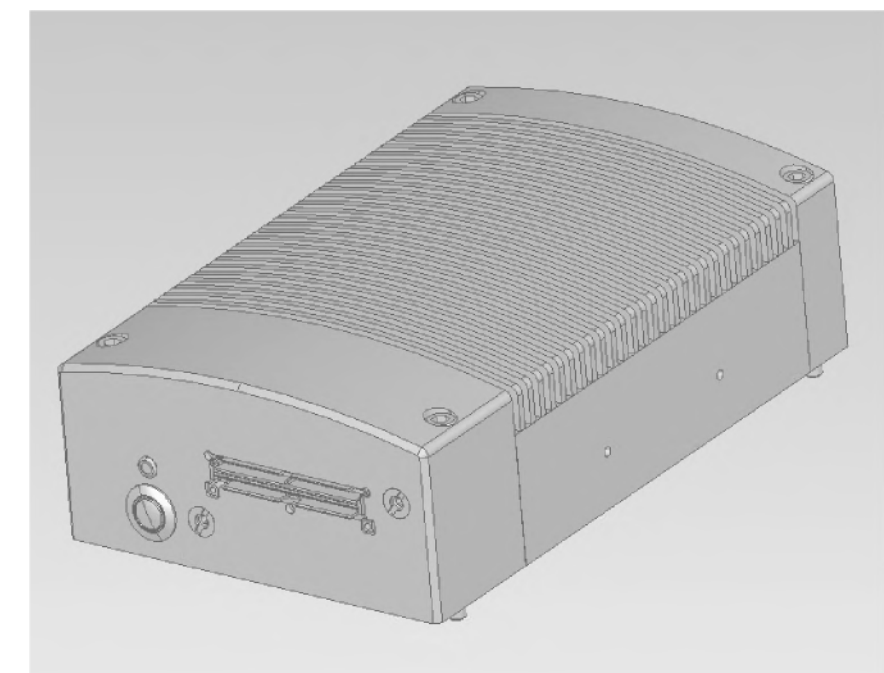

Necessary technology

07

Control cabinet "**Charlie**" with I/O link architecture

Our special control cabinet contains an IPC for the software applications, is based on I/O link architecture for cascability and can carry optional any PLC for safety integrations

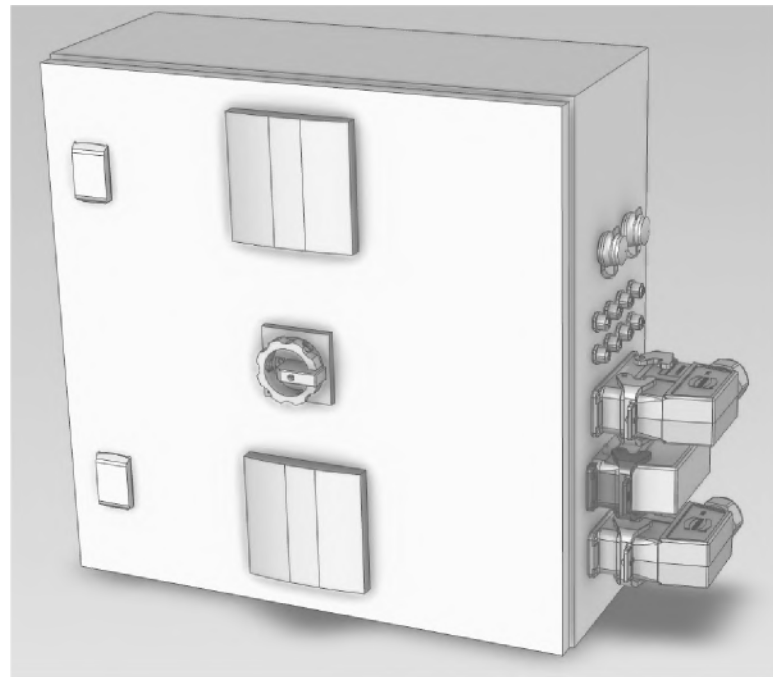

08

EOAT "**Hardy**" all-in-one tool collaborative approved

Miniaturized end-of-arm-tool (270 mm length), combined with the newest phased array probe for highest precision in ultrasound inspection

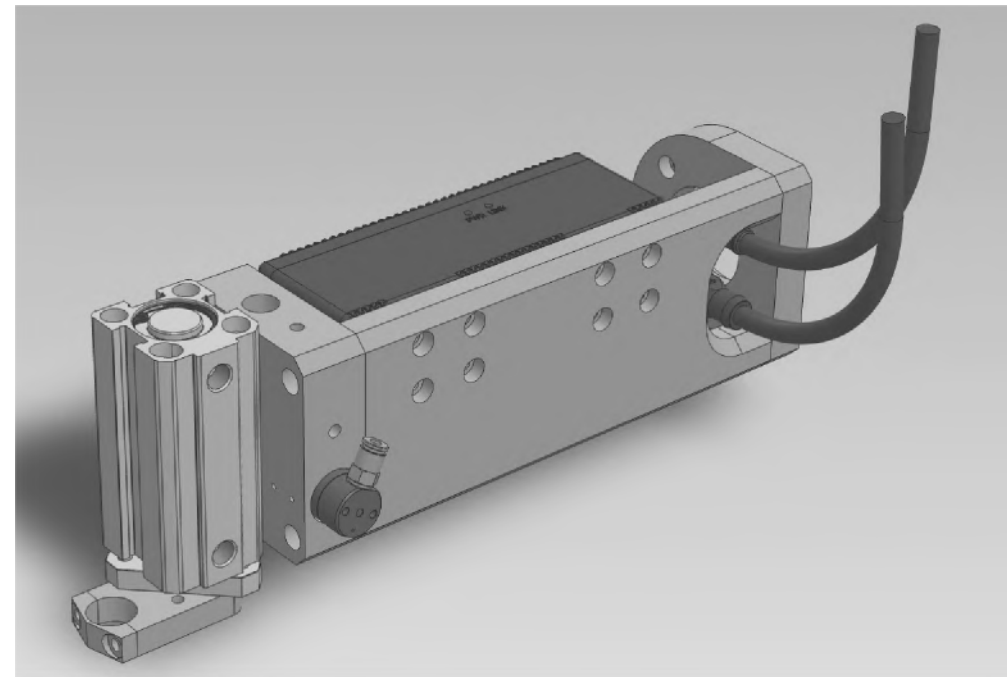

09

Sprayer system "**Dolphin**" for optimally UT coupling

An effective sprayer system dispenses not too much and not too less water to the surface

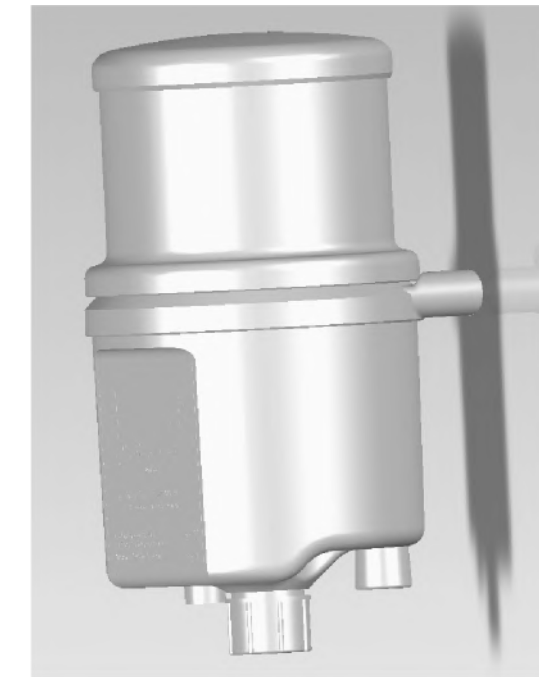

mobile self calibrating system - position and parts with a new era of 3D vision "Hawk"

- Vision software running on deep learning AI software system
- Orientating of the robot system in the room (6D)
- Find and calibrate the component against the system (6D), doesn't matter if it is just a part or a full car body
- Find and identify the spot welds on the surface according to a test plan or in free mode
- See the indentation and according to that, recalculate the positioning of the probe in relation to the specific spot
- See burrs and splatters at the specific spot to avoid damage of the membrane while touch sharp corners

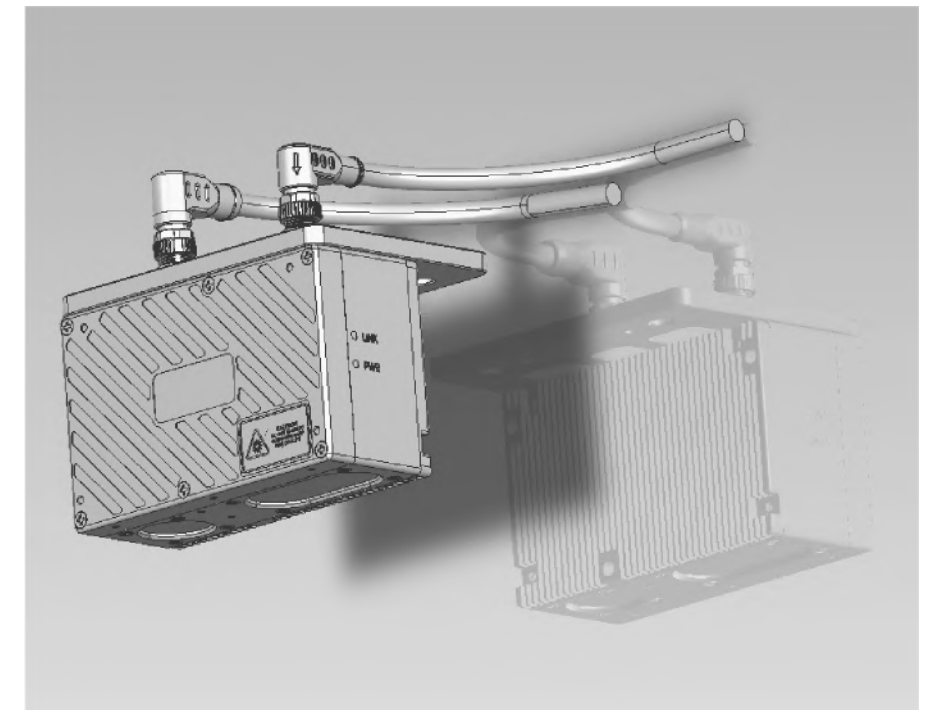
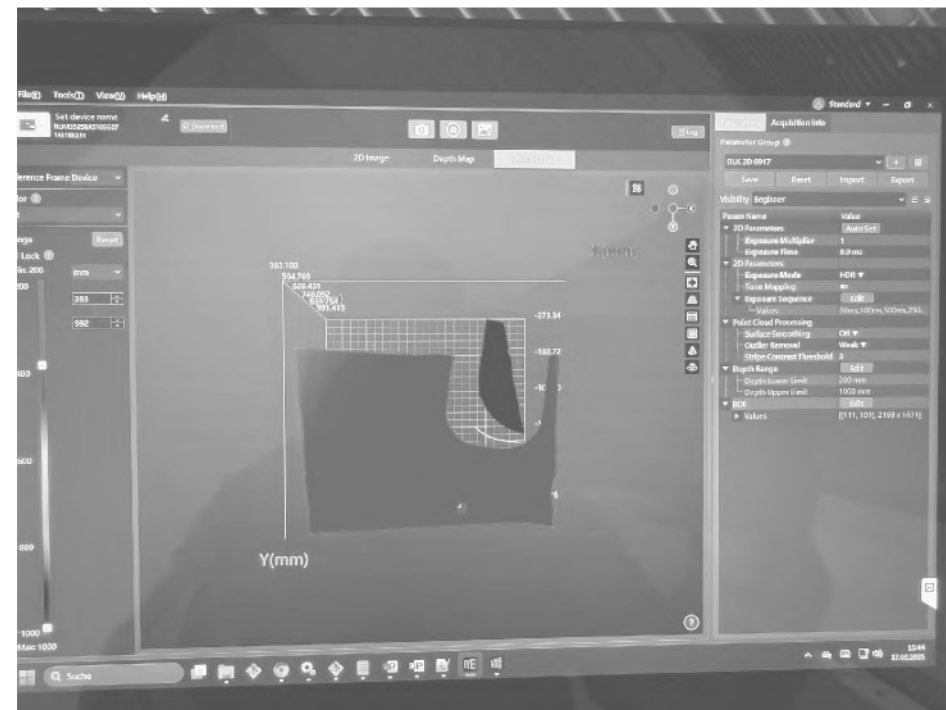
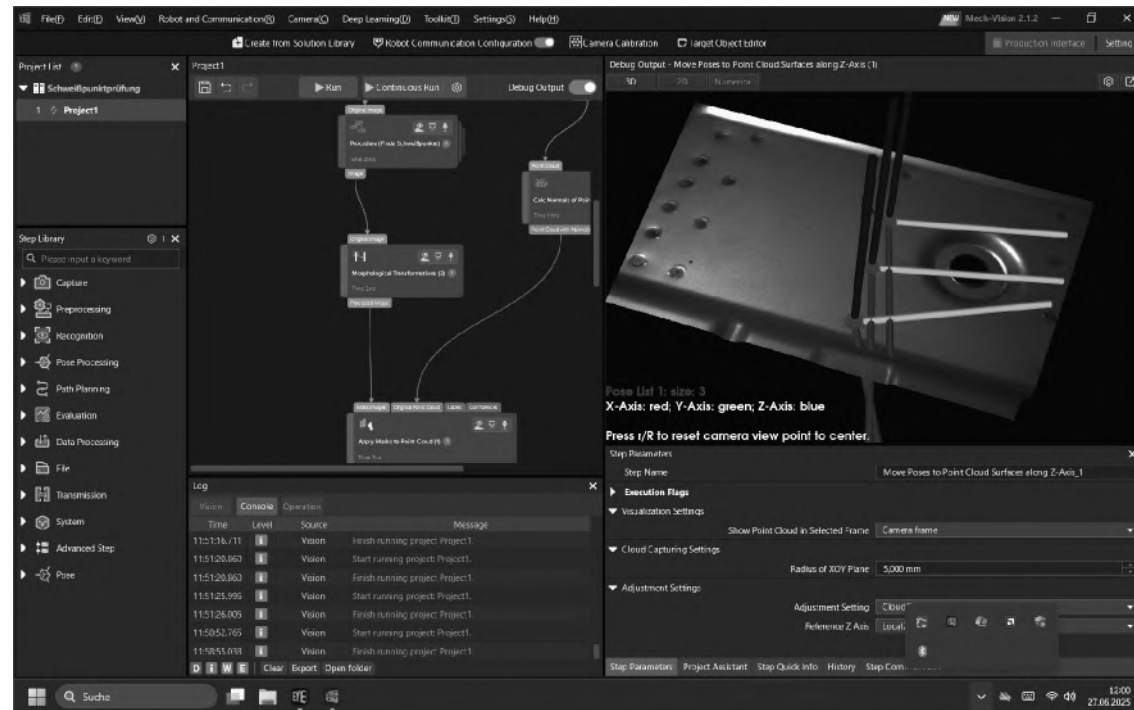

HMI - user interface and operation software "Octopus"

- Inspection part and order management
- HMI Human machine interface
- collaborative robot control (all brands, all models)
- Industrial robot control (all brands, all models)

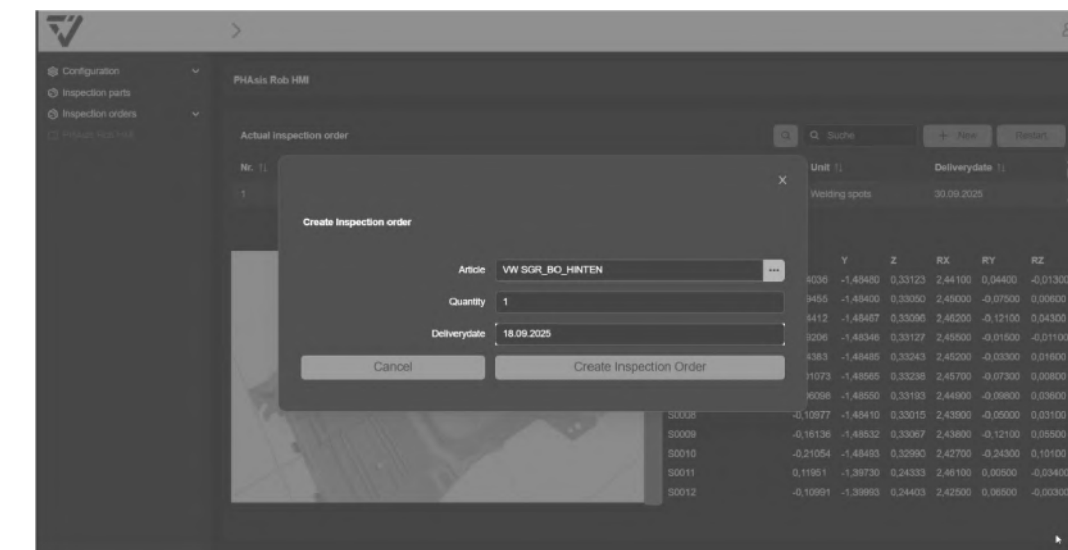
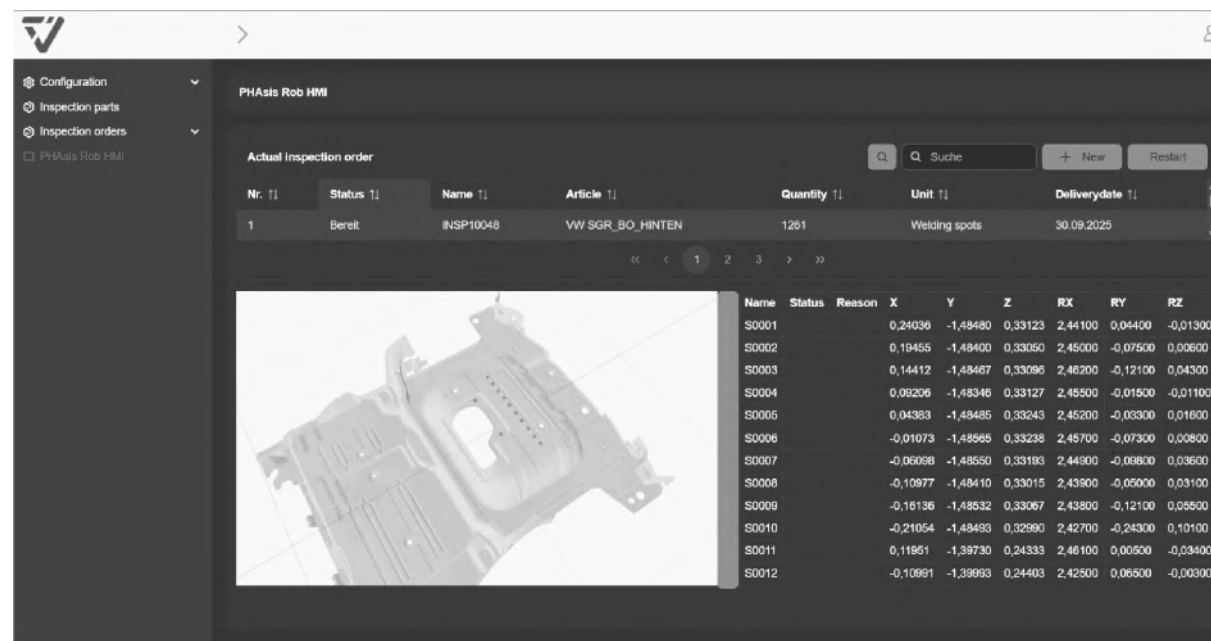

Ultrasonic device with software package KAI "PHAsis BLU"

- Phased array ultrasonic system with 121/64 element probes
- **AI driven** software with multiple options for inspection strategies
- spot weld inspection in steel and aluminum, 2-layer, 3-layer, MRD, RobSpin
- adhesive bonding inspection point-based and for areas

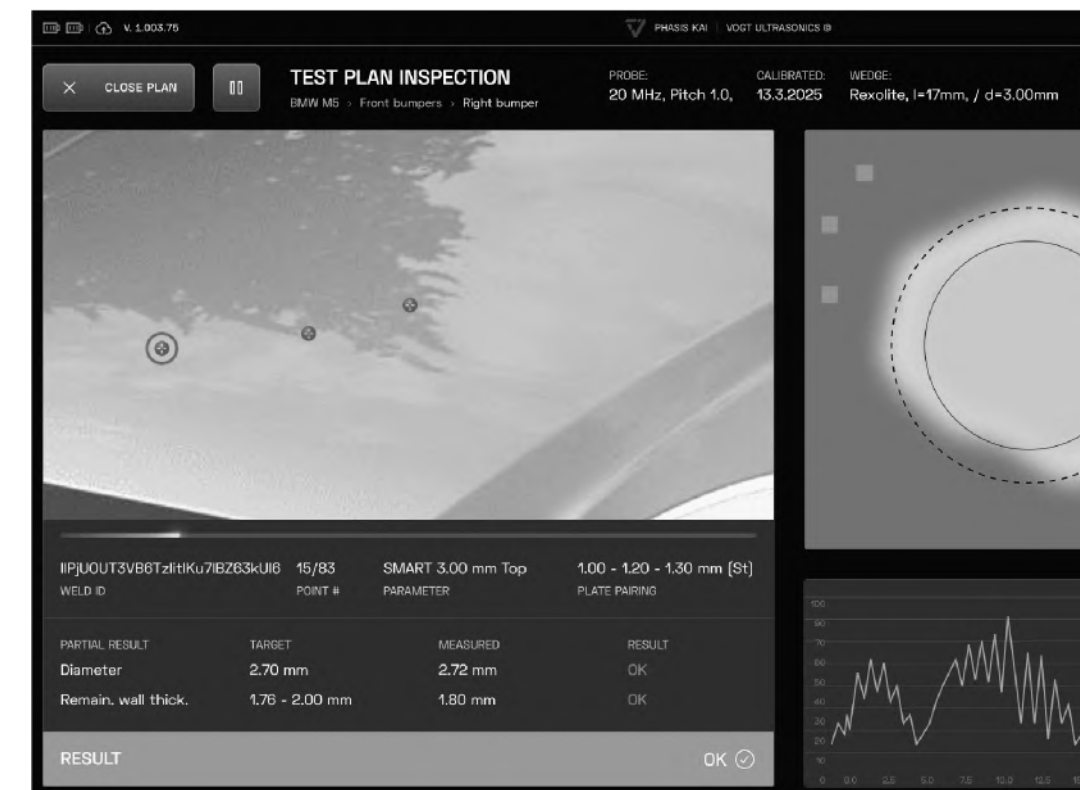
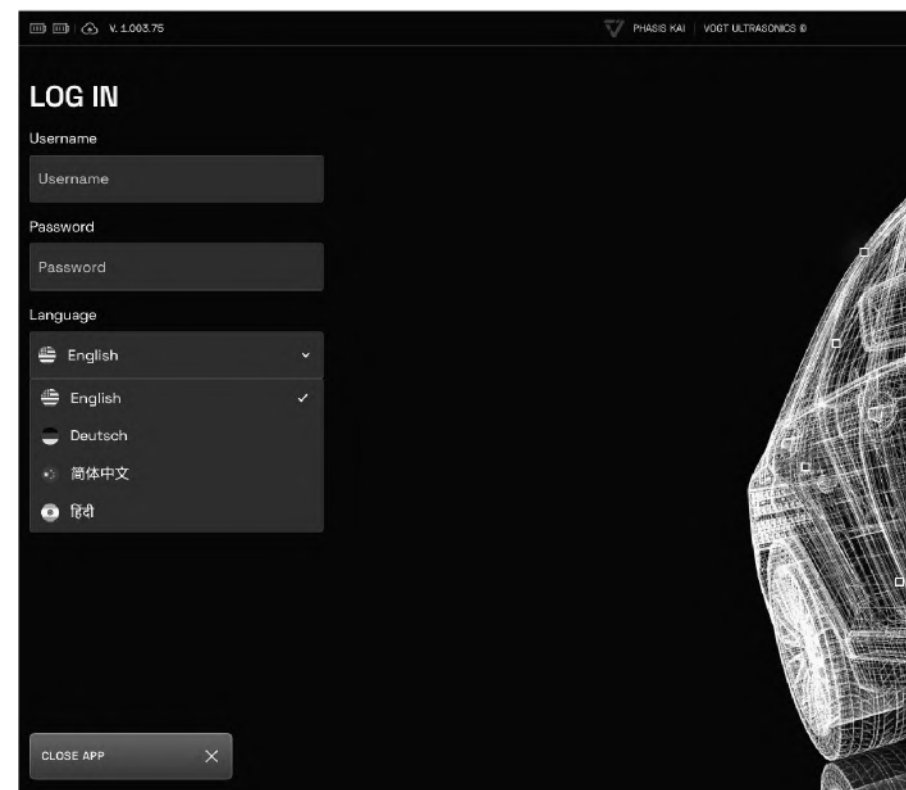
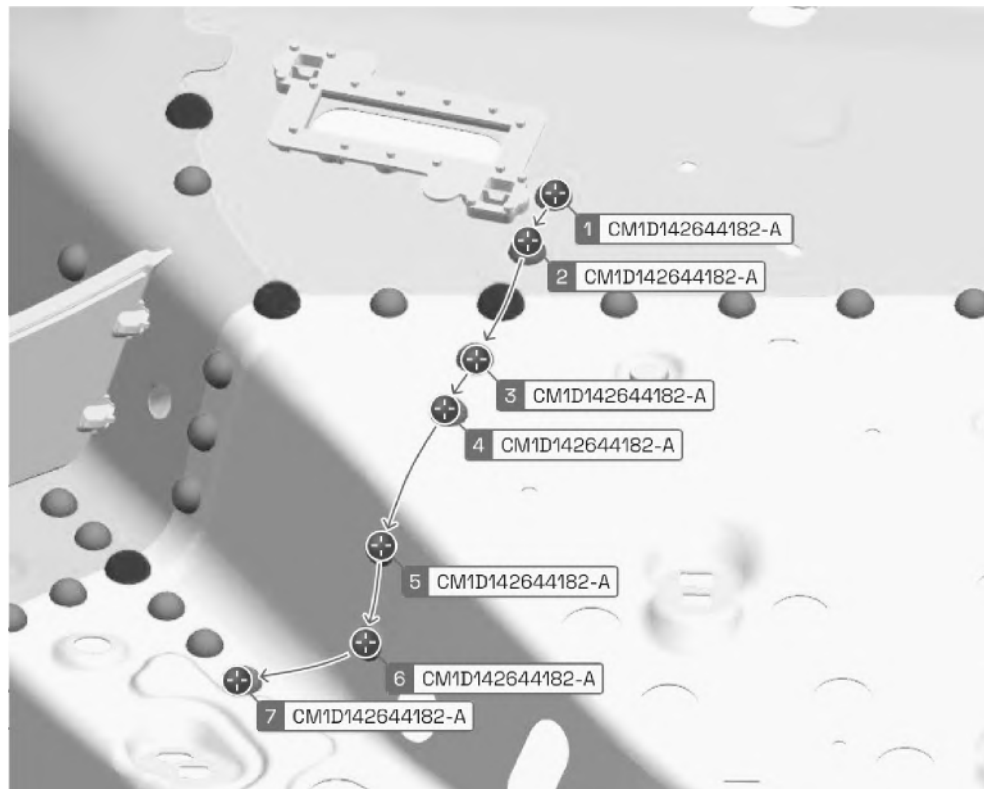

End of arm tool EOAT "Hardy"

- ultra compact housing for optimized reachability
- home of the ultrasonic probe and the sprayer nozzle
- carrying the 3D vision system Hawk with maximum degrees of freedom
- laser pointer for advanced teach-in processes

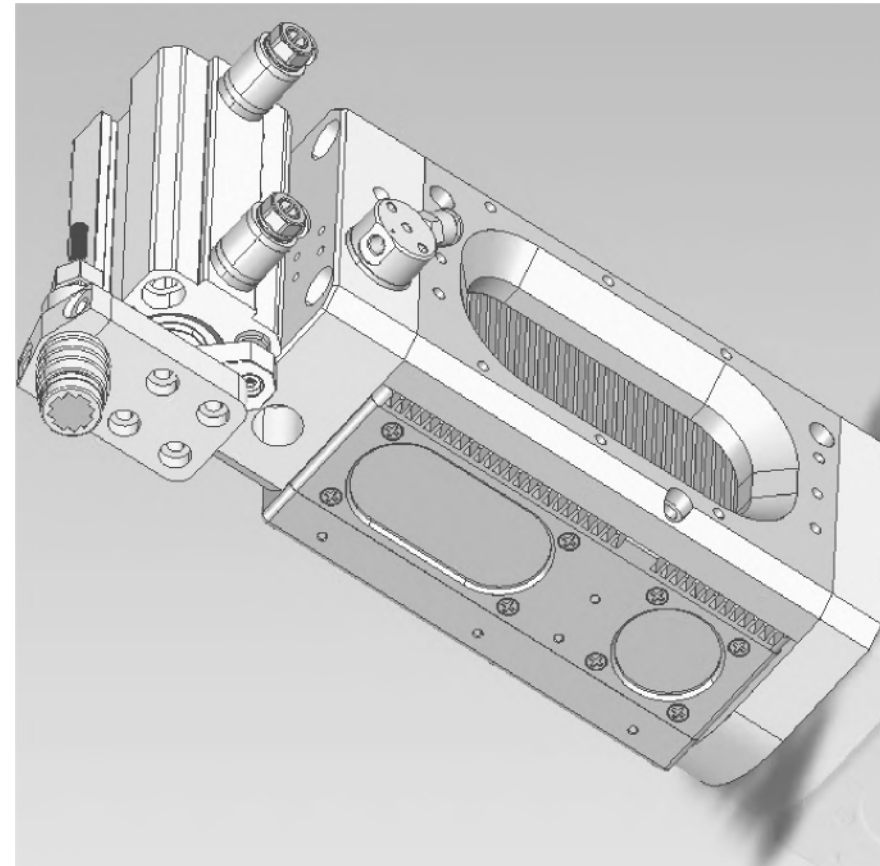
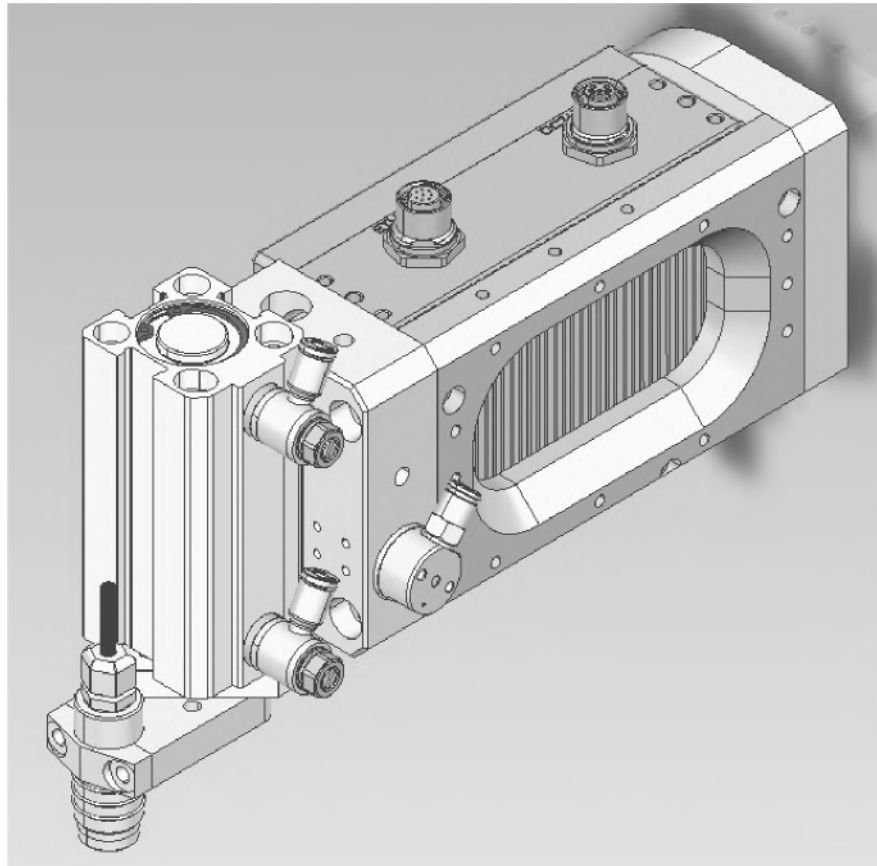

OCTOPUS - operating system MODULES

Inspection part and order management

Manages the creation and tracking of inspection parts and orders, allowing users to define part types, track individual inspection demands, and schedule and monitor multiple inspection orders. The system is built on a 100% Java/Jakarta, service-based architecture with an SQL database for traceability.

Inspection part import and plan import

Allows for flexible data import of both inspection parts and plans. Parts can be imported via predefined MS Excel imports, while plans can be imported using various file-based protocols, databases, OPC UA, or web services. The system can be extended to import from IT systems like SAP or Infor upon request.

Manual robot teaching

Assists operators in creating and saving robot waypoints, welding spots, or reference points using a graphical user interface. No coding skills are necessary, as the interface guides users through point creation, adjustment, and deletion.

Inspection result export

Enables the customizable export of inspection results using the same interface technologies as the import function. This allows the system to comply with specific customer IT/OT infrastructure and protocols. Predefined exports to ERP systems like SAP or CAQ systems such as SIEMENS Opcenter Quality are available upon request.

STEP CAD import, welding point extraction, and transformation

Imports STEP CAD files and extracts spherical points representing weld locations from the geometry, automating the setup for inspection or welding tasks. It includes an interactive viewer for manual verification and converts the extracted CAD points into robot coordinates for precise path planning.

Human Machine Interface (HMI)

A user-friendly, HTML5-based interface that displays real-time equipment status, error messages, and information prompts. It allows operators to easily run inspection workflows and monitor robot and process status via simple screens¹⁴. The HMI can be adapted to specific customer needs and workflows.

OCTOPUS - operating system MODULES

Collaborative robot and industrial robot control

Provides cell management for controlling both **collaborative robots** and **industrial robots**, integrating advanced devices like 3D AI cameras and various sensors. The system includes real-time monitoring, feedback, and diagnostics for quick troubleshooting. It natively supports Universal Robots, Nachi, and Fanuc, with the ability to integrate other brands upon request.

Value chain of the complete system - service part

Installation and commissioning
on site

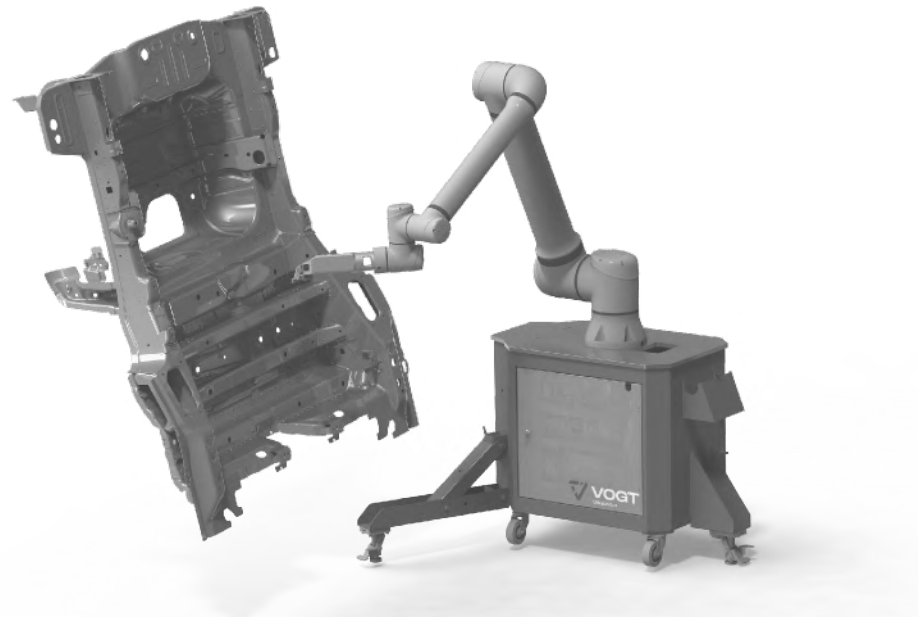

- Installation of VOGT PHAsis Roby in production environment
- software installation and adaption
- calibration of vision and complete system
- interface installation to superior data systems
- ultrasonic hard- and software installation
- commissioning the complete system

Benefits



Modern user interface seamless integration e.g. with hand units PHAsis NEO and PHAsis ROB/Roby

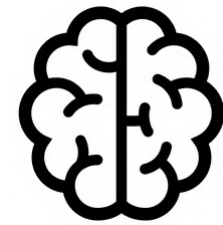

High precision with AI beyond traditional methods' capabilities

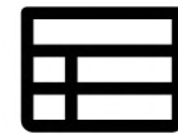

extended database connectivity



Multi-user access & roles for inspection teams



HMI & setup easy to use for operators and admins

AI Enhanced User Experience

- **Automated Measurement Planning:** AI automatically generates an optimal measurement plan, significantly accelerating the process and improving user efficiency
- **Improving Data Entry Efficiency:** AI prefills a major part of user input fields based on detected user intention, greatly increasing speed of use

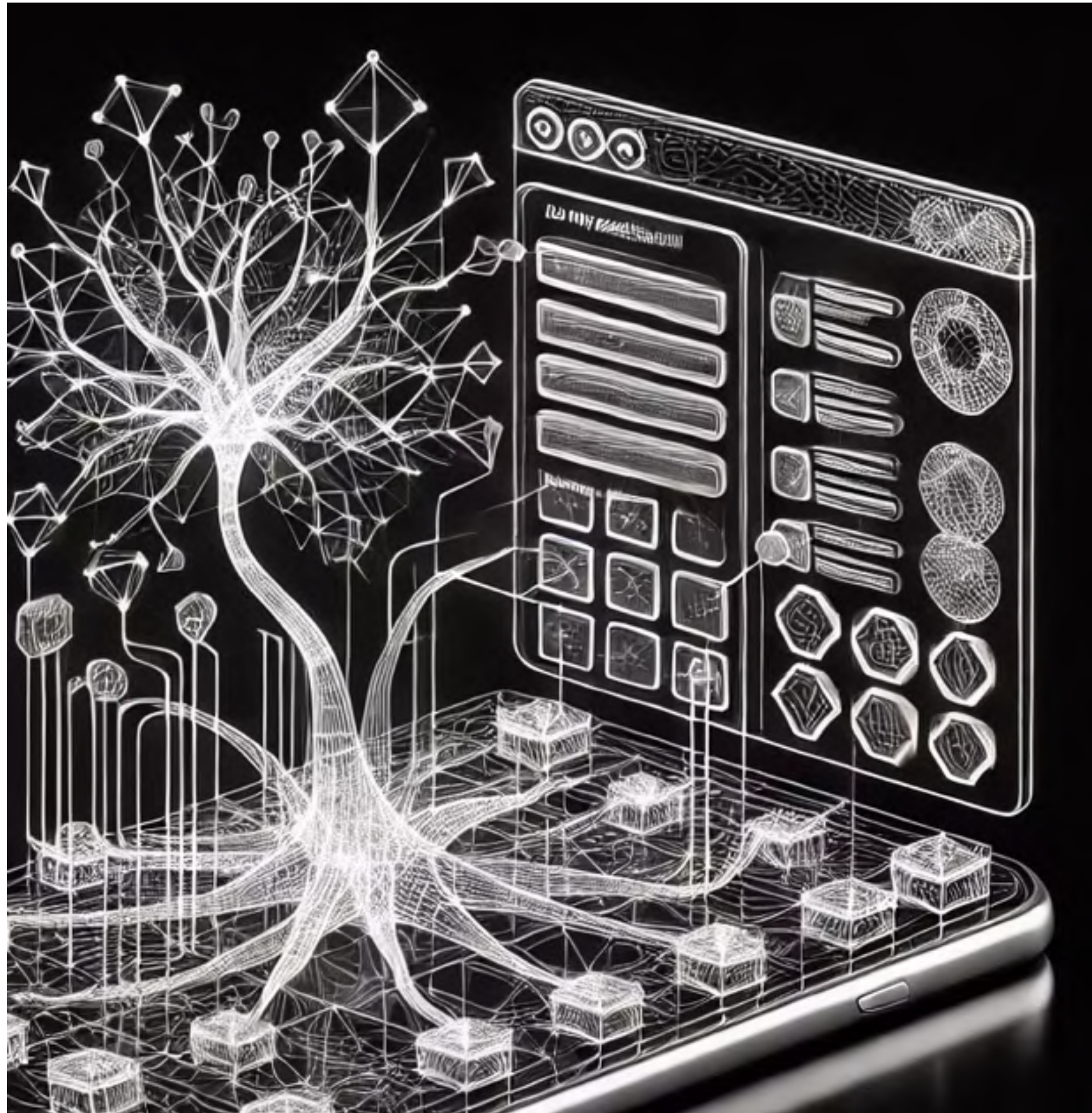

AI High Precision Measurement

- **Traditional methods** rely on thresholds and filters to extract a small subset of data for analysis.
- In contrast, **AI can process raw, high-dimensional data**—hundreds of thousands of values—unlocking much higher precision and deeper insights.
- Zinc cladding detection: A good example where this method brings a whole new feature that was previously out of reach

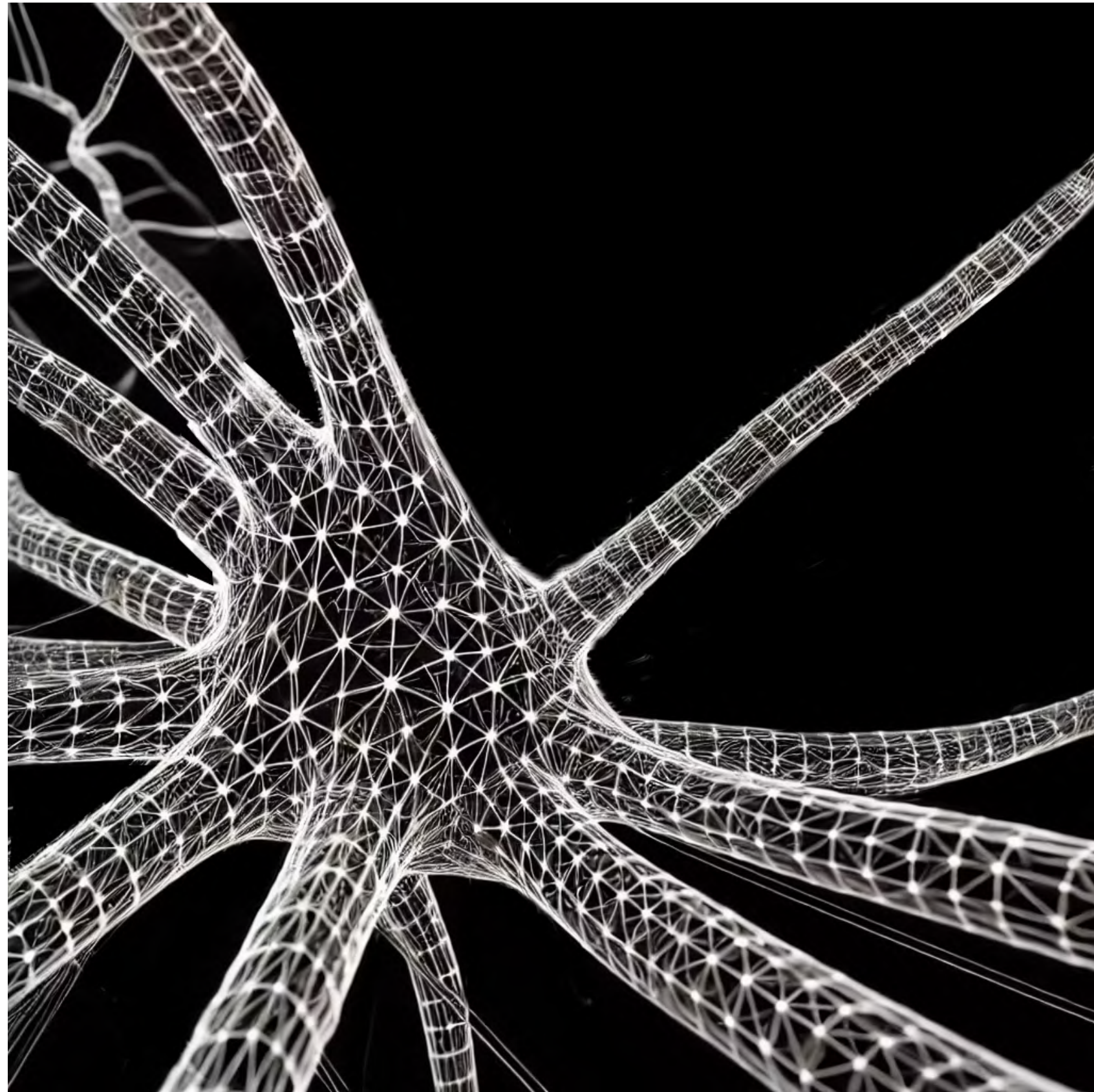

PHAsis ROBy

An automated platform for ultrasonic inspection.

