

UK STOCK
SAME DAY
DESPATCH

ISOTOOLS

**ENGINEERED FOR PRECISION
BUILT FOR PERFORMANCE**

— Selected by Experts —



The logo for ISO TOOLS, with 'ISO' in gold and 'TOOLS' in white, set against a dark blue background with a gold sunburst graphic in the top left corner.

ISO TOOLS

WELCOME TO ISOTOOLS LTD

Selected Cutting Tools. Proven in Production.

ISOTOOLS specialises in supplying high-performance cutting tools that deliver reliable results in real-world machining environments.

This brochure presents a carefully selected range of cutting tools chosen by our technical specialists based on proven performance within the metalworking sector. Each product has been validated in production to provide **consistent tool life, high quality surface finishes, and outstanding value.**

Our focus is simple:

to supply precision tools that help manufacturers increase machining capacity, improve productivity, and maximise profitability.

With extensive UK stock and same-day despatch on selected lines, ISOTOOLS ensures you get the tools you need — when you need them.

WHY CHOOSE ISOTOOLS?

- ✓ Selected by experts
- ✓ Consistent tool life & high quality surface finishes
- ✓ Proven in production
- ✓ Stocked in the UK
- ✓ Same-day despatch available
- ✓ Technical support you can rely on

A collection of various metal cutting tools, including end mills, drill bits, and reamers, arranged in a row against a dark blue background.

T: 01329 237 466

ISO TOOLS

SP210 ENDMILL

FOR HIGH EFFICIENCY MACHINING

Introducing the **SP210 4 Flute Variable Helix Endmill**, engineered for high-efficiency machining across a diverse range of materials, including steels, stainless steels, cast iron, and exotic alloys.

This endmill offers exceptional value amidst rising carbide prices, ensuring you get the most out of your investment.

Available in square corner, corner radius, corner chamfer, and ball nose types, it delivers market-leading performance that meets the demands of any machining project.

Elevate your machining capabilities with the SP210 and experience unparalleled precision and durability.

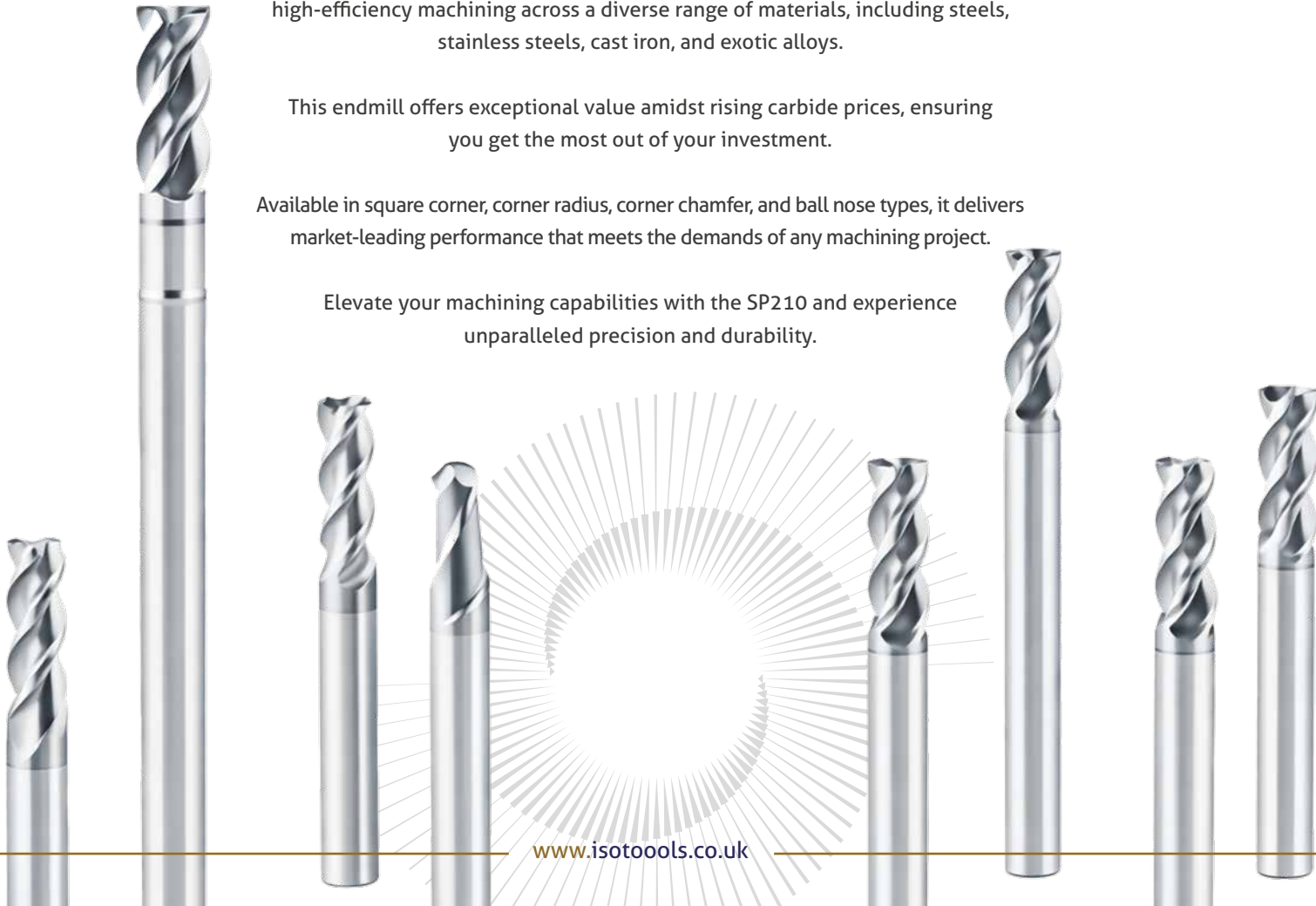

www.isotoools.co.uk

ISO TOOLS

ALUMINUM ALLOY ENDMILL RANGE

High Performance Endmills for Efficient Aluminum Machining

SA100 High Efficiency Milling of Aluminum Alloy

- Optimized geometry for rough milling and semi-finishing
- New DLC (Diamond-Like Carbon) coating for enhanced performance and wear resistance
- Proven top-tier performance against market leaders at reduced cost.

UA100 General Machining of Aluminum Alloy

- Versatile tools ideal for general aluminum and copper alloy machining
- Special edge design reduces vibration and built-up edge of cutting tools
- Available in a variety of sizes, corner radii and lengths for same day despatch to suit your machining needs.



STEEL TURNING INSERT RANGE

High Performance Inserts for Steel Machining

Steel Turning Inserts

**GPT6 Series – Advanced grades
for steel machining**

- Available in both positive and negative ISO insert styles
- Geometries (GP, QM, QR, QH, MM) for all machining stages
- QM first choice for negative turning, MM for positive finish turning
- Optimised for roughing, semi-finishing and finishing
- High wear resistance for extended tool life
- Stable performance in continuous and interrupted cuts
- Proven performance in aerospace and general steels

Cermet Finishing Inserts

**GPT3 Series -
High-performance cermet**

- Designed for high-speed finishing of steels
- Excellent surface finish and dimensional accuracy
- Heat-resistant grades for stable machining
- Consistent performance in finishing applications

Why Choose Cermet?

- Superior surface finish vs carbide
- Reduced built-up edge
- Higher cutting speeds in finishing
- Consistent tool life in stable conditions

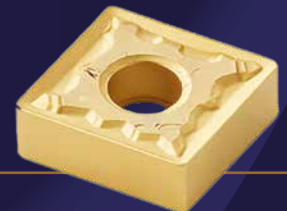
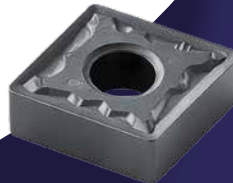
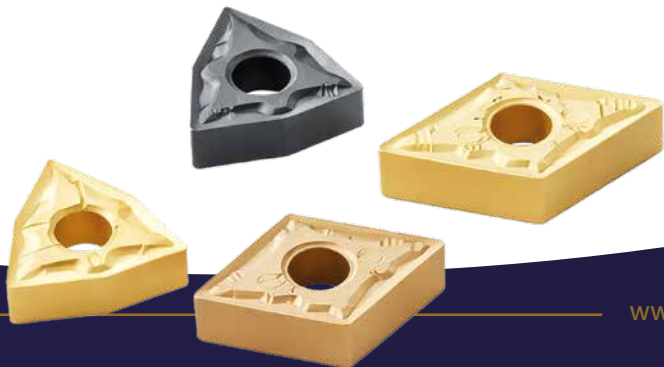

ISO TOOLS



ADVANCED TURNING SOLUTIONS

CBN for Hard Turning & PCD for Non-Ferrous Applications

CBN Hard Turning Solutions

Precision machining for hardened materials above 50 HRC

Product Highlights

- Newly developed TiAlN coating for enhanced wear resistance and high temperature performance
- Dedicated grades for light interrupted and continuous hardened steel machining
- Optimised grades for general purpose hardened steel applications
- High toughness grades for heavily interrupted steel machining

Applications

- Hardened steels above 50 HRC
- Bearings, shafts and precision components
- Finishing operations replacing grinding

PCD Turning Solutions

High performance machining for non-ferrous and abrasive materials

Product Highlights

- Exceptional tool life in aluminium and non-ferrous materials
- Outstanding surface finish for high precision components
- High resistance to wear in abrasive materials and composites
- High speed machining capability for increased productivity
- Reduced built-up edge for consistent and reliable performance

Applications

- Automotive and aerospace components
- Aluminium and non-ferrous materials
- Composite and abrasive materials
- High precision finishing operations

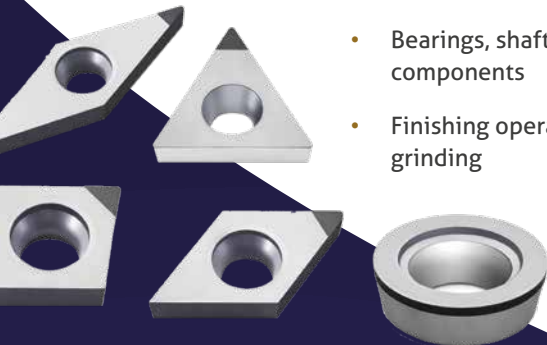



ISOTOOLS

PRECISION THREAD TURNING SOLUTIONS

External & Internal Threading Tools

Thread Turning Solutions

High performance threading for the most demanding applications

- Strong performance in difficult to machine materials
- Stable clamping systems for maximum process security
- Optimised geometries for reliable chip control and consistency

Engineered for Performance

GM3 grades for enhanced performance in threading applications

- Proven performance against market leaders
- Exceptional tool life in demanding production environments
- Reliable performance in difficult to machine materials
- Consistent results across batch and high-volume machining
- Engineered for process stability

Available in a wide range of options

- External and internal threading, right-hand and left-hand
- Available in 11, 16 and 22 insert sizes
- ISO metric, UN and BSP(W) thread forms available





THREADING TOOLS

Quality without compromise

Complete threading solutions including high performance taps, dies, gauges and tap-extensions.

Precision Threading Solutions

Engineered for Quality

ISOTOOLS is proud to partner with Hahnreiter Gewindetechnik, bringing over 150 years of German manufacturing excellence in threading tools to the UK market.

Building on an established presence, this partnership combines Hahnreiter's engineering heritage with ISOTOOLS' local expertise and technical support — delivering enhanced service, availability, and application support to customers across the UK.



ISOTOOLS

Technical & Distribution Partner

Why Hahnreiter?

150+ years of German engineering excellence in threading tool manufacture.

Hahnreiter provides a comprehensive range of standard solutions alongside application-specific tooling.

Proven performance with consistent thread quality, longer tool life, and reduced downtime.

ISO TOOLS Ltd

Unit E4 Fareham heights Standard Way Fareham PO16 8XT

www.isotools.co.uk t: 01329 237 466 f: 01329 237 467

