

**Wickman**  
[www.wickman-group.com](http://www.wickman-group.com)

Precision and productivity with CNC multispindles from Wickman

*Better lathes, better results*



[www.wickman-group.com](http://www.wickman-group.com)

# Wickman *Better lathes, better results.*

## Welcome

We are a global supplier and manufacturer of multispindle lathes, designed to produce medium and large volumes of extremely precise, high quality components. Our services and sales network extends to all parts of the world, with offices based in the UK, Brazil, USA, China & India.

Our key industries: automotive, aerospace, defence, agriculture, hydraulic, white goods, electronics, oil and gas.

We manufacture multispindle lathes with CNC, servo or CNC & PLC control, capable of turning components from 5mm up to 82mm diameter.

In 2000, when Owen Coyne and Chris Barrett took over Wickman, they revitalised a brand with a long tradition of excellence. Since the 1930s, we have been known for producing quality multispindle lathes with a forty or fifty years lifespan. Aftercare and service are fundamental aspects of our approach, demonstrated through continually providing spares for machines we originally made many decades ago.

As well as manufacturing world-renowned multispindle lathes, we also provide products and services from our associated companies – and turning machines, Manurhin CNC sliding head machines and Cucchi Bar Loading Technology.

### ♥ Customer-focused company

We are a customer-focused and driven business. We offer solutions that increase efficiency and productivity for our customers and always aim for affordable technical solutions so that we can give our customers a great deal!

### 🌐 A global company

Wickman sales, service and technical support are recognised to be the best in the world. Selling a machine is only part of the process; every sale comes with a commitment to our customers. We are proud to build long term business relationships with our customers worldwide and give them all the support that we can.

### 👍 A company that understands

From an operational point of view, we guarantee maximum flexibility in terms of costs and needs of all our customers both old and new. We tailor machines to suit the buyer's specific requirements; we understand the importance of customer service.

### 📈 A sustainable and successful company

Over the last 12 years, we have extended our product range, developed their global services and support system and invested in a focused, successful team. We are proud to be a leading global supplier of high quality and affordable machinery to the turned parts industry.

## What you see is what you get

Our employees pride themselves on being open-minded team players and understanding the customers' needs and requirements. Our management team use a practical approach to achieving clearly defined targets that are reviewed annually.



TANGI-FLOW

## Wickman CNC Range

CNC multispindles from Wickman are designed to meet the requirements of the modern machining world. Where you need superb machining accuracy, the strength to machine tough materials and produce complex shapes, you need something special. Our CNC machines are ideal where high outputs are required, with improved processes, increased efficiency and rapid set-up. They are built to be exceptionally reliable and inexpensive to maintain. All models are designed to deliver precision components, time after time, without continuous re-adjustment.

These machines combine the standard Wickman machine format with the advantages of CNC controls and AC Drive technology. The familiar Wickman construction avoids the difficulties and expense of re-training operators and setters. In addition, tooling and attachments are fully compatible with other Wickman machines.



### Lubrication

ACW range are specified as standard with a monitored cutting oil delivery system  
Standard system can deliver up to 200 litres per minute through multiple valve controlled outlets

**Upgrade is available on request to meet your coolant control requirements:**

- Mid to High pressure coolant system
- Micro filtration
- Dry sump Oil chilling
- Removable swarf tray

### Safety

New, enclosed guarding system offers the best in health, safety and environmental protection. Acoustic covers provide excellent sound insulation and oil spillages are reduced for safer working conditions. The fully interlocked system is CE and OSHA ready.

## Range

A superb range of adaptable and dependable lathes which are fully configurable for up to **28 CNC controllable axes**. Our 7 Axes Standard Machine is complete with 2 axes CNC cross slides position 4 & 5, single axis main tool centre block & single axis control of the upper independent end working slides 4 & 5.

Custom CNC slides available on request.



## Control

Simple to program advanced systems give the operator complete control of coolant, conveyor, spindles, lights, guards and interlocks. Incorporating a full, clear display panel on each side, controls can be configured for up to 28 axes.

- Siemens 840Dsl / Fanuc 30i
- Touchscreen and keyboard
- ISO programming Windows based control
- % speed and feed overrides
- Machine cycle start / stop

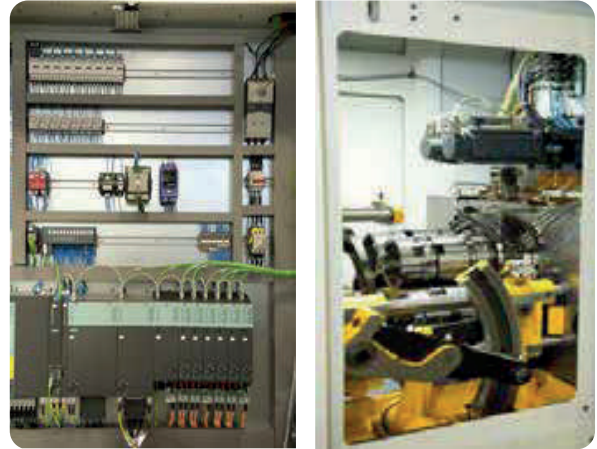

## Options

We are delighted to tailor our CNC models to our customer's exact requirements. Please talk to us about the many options and bespoke solutions that we can supply.

# Attachments

## Pick up

- Hydraulic or Pneumatic pick up & back machine
- Pick up & brake
- Heavy duty back machining slide

## Threading

- Single point CNC internal and external thread cutting
- Thread milling
- Thread rolling
- Tapping – pneumatic or standard clutch type

## High speed drilling

- Standard Wickman configuration
- High pressure through spindle coolant

## Recessing

- Ramp recessing
- Push over recessing
- Recess milling

## Flat generating

- Plunge type
- End working type
- Quill type
- Reverse type

## Slotting, drilling & end milling

- Synchronous slotting – frontal type, on & off centre
- Synchronous radial drilling and milling
- Phased milling and slotting

## Reaming and broaching

- Slow reaming spindle or advanced (accelerated) type with synchronous spindle
- Driven broaching/drifting – synchronised rotating spindle
- Non-driven, free-revolving broaching *i.e. Tangi-Flow*

## Component marking

- Roll marking – applied from the cross slide
- Frontal marking head – applied from the centre block to mark the front of part

## Cross slide drilling, tapping and milling

Spindle stopping option only

- Cross drilling – single or multi drill\*
- Cross tapping
- Cross milling – flat bottom, slot, dual slot etc.

## Toolholders and collets

- Compatible with all standard Wickman toolholders and collets



\*Subject to machine configuration

# Technical Specifications

Figures shown below are based on a STANDARD 7 axis CNC multispindle lathe.  
Custom CNC slides & extra axes are available on request.

	6-25	6-44	6-57
Machine control	Siemens 840D / Fanuc 30 i	Siemens 840D / Fanuc 30 i	Siemens 840D / Fanuc 30i
Maximum bar capacity			
Standard stock reel	26 mm	44 mm	57 mm
With bar loader	28 mm	46 mm	59 mm
Spindle speeds	900-3500 rpm	150-2250 rpm	50-2000 rpm
Spindle motor power	28kw	37 kw	37 kw
Feed stroke - centre block	127 mm	178 mm	230 mm
Cross slide strokes			
Position 1 & 2	0-25.4 mm	0-32 mm	0-35 mm
Position 3 & 6	0-25.4 mm	0-32 mm	0-35 mm
CNC cross slide strokes			
Positions 4 & 5	X-46 mm Z-90 mm	X-90 mm Z-74.5 mm	X-90 mm Z-150 mm
CNC independent slide	W-127 mm	W-150 mm	W-230 mm
CNC slide feed rates	0-15,000 mm	0-15,000 mm	0-15,000 mm
Index time	1.4 seconds	2 seconds	2.5 seconds
Machine weight	5,200 kgs	8,100 kgs	10,100 kgs

All technical data given is for guidance purposes only and may be subject to change

# Machine Dimensions

## WICKMAN CNC MACHINE

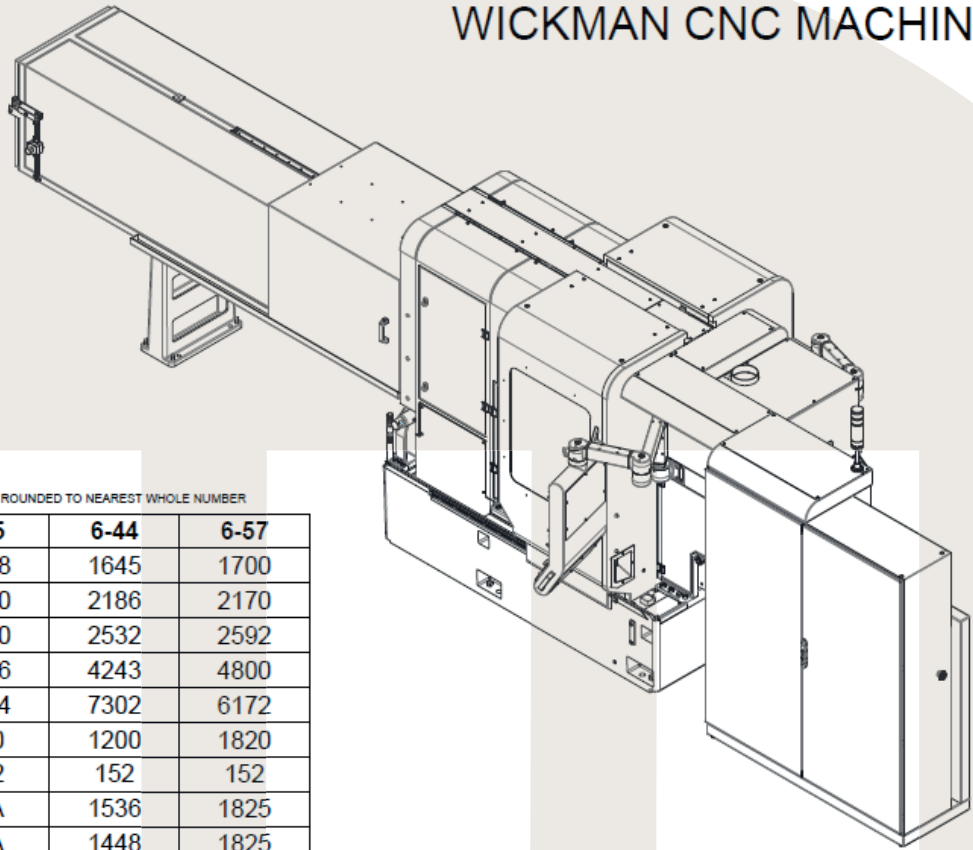

DIMENSIONS IN 'mm' - ROUNDED TO NEAREST WHOLE NUMBER

	6-25	6-44	6-57
W	1028	1645	1700
H1	2200	2186	2170
H2	2600	2532	2592
L1	3346	4243	4800
L2	6254	7302	6172
C	800	1200	1820
ØE	152	152	152
P1 (max)	N/A	1536	1825
P2 (max)	N/A	1448	1825

## WICKMAN CNC MACHINES

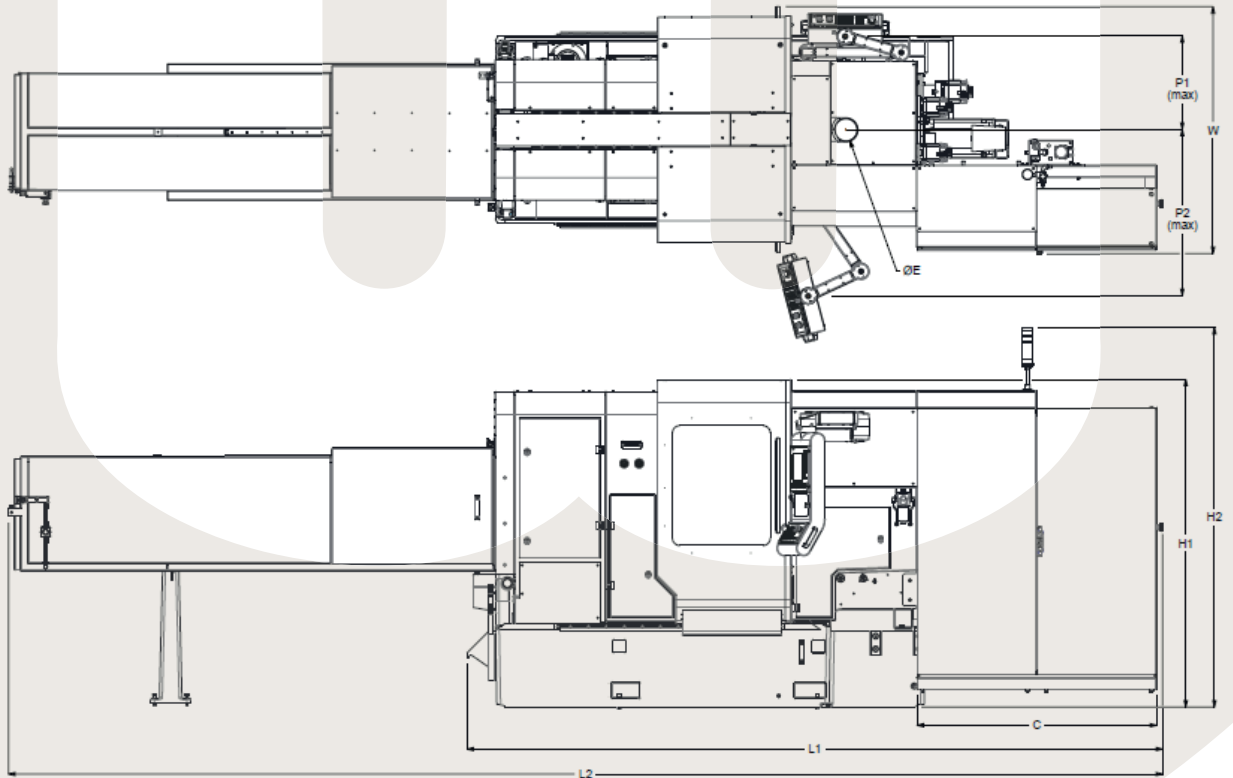

## Other Machines in our Range

### Wickman ACW Servo

Wickman ACW lathes combine the standard Wickman machine format with the advantages of the AC-drive technology. Their familiar construction avoids the difficulties and expense of re-training operators and setters, in addition, tooling and attachments are fully compatible with other Wickman machines.



## Wickman Worldwide

Let Wickman provide and support your turning needs  
for now and in the future

Brazil: 0055 (0) 19 3515 7337

Poland:

0048 (0) 42 658 0065

France: 0033 (0) 450 340041

UK & Rest of World: 0044 (0) 2476 547 900

Spain: 0034 (0) 679 714 195

USA:

001 847 458 6400



India: 0091 (0) 9902095976/79

China:

0086 (0) 512 3687 7999



Wickman Group, Automatic House, Discovery Way, Binley, Coventry, UK, CV3 2TD  
T: 02476 547 900 E: enquiries@wickman-group.com W: www.wickman-group.com

 @Wickman\_group  Wickman Group



[www.wickman-group.com](http://www.wickman-group.com)