

SCHMIDT® ManualPress

From 1.6 kN to 22 kN

Efficient manufacturing requires appropriate means of production – not always automation. In particular, with small production runs, manual presses are often the most cost effective solutions.

We are continually developing the range of manual presses so that you can achieve your production targets. The expertise we have gained from our exposure to numerous production applications has been implemented in our new models. Therefore, we can offer a wide range of manual presses to suit all requirements.

Characteristics

- Flexibility
 - Rapid changeover due to the easy and secure adjustment of the working height
 - Table tops with precision T-slot and precise alignment between the ram and table bores allow for accurate and repeatable set ups which reduces set-up times
 - The original position of the hand lever can be varied by 360°
 - Horizontal pull (111/113)
 - Available for left-handed and right-handed use
 - The return stroke force of the ram can be adapted to different tool weights
- Precision
 - Alignment < 0.05 mm between upper and lower tool
- Maintenance-free
 - No lubrication necessary
- Long service life

Depending on the application, there is a wide selection of rack-and-pinion presses and toggle presses to choose from. Furthermore, a modular product design gives you the opportunity to choose the appropriate press for your application.



SCHMIDT® Rack-and-Pinion Presses

Constant force over the entire stroke

Do you need force over a longer stroke distance for assembly processes? Then **SCHMIDT® Rack-and-Pinion Presses** are the right choice.

Characteristics

- Long stroke
- Linear force progression
- Precise adjustment of the press depth via an integrated hardened adjustable stop
- Honed ram guiding and ground rams provide a long service life and a precise guidance



Press Type 5



Press Type 3 or 5



Press Type 1 or 2



Improved return stroke mechanism for rack-and-pinion presses No. 3 and 6 with stroke 100 mm and 160 mm

The use of a spring package optimized specifically for large strokes improves ergonomics significantly. In addition, the use of the **Ergohandle** ensures that even with angles of rotation $>360^\circ$, no switching of hand position is necessary. The force feedback on the hand lever is kept as constant as possible over the entire stroke by a balance weight.



Press Head

No.1 and No.2 have a ground guidance plate and teflon-coated adjustable gibs for precise and torsion-proof guidance.

From 1.6 kN to 2.5 kN

Press Type		5	5R	3	3R	6	6R	1	1R	2	2R
Press head type		5	5R	3	3R	3	3R	1	1R	1	1R
Nominal force	kN	1.6	1.6	2.4	2.4	2.4	2.4	2.5	2.5	2.5	2.5
Working stroke up to	A mm	40	40	70	70	70	70	80	80	80	80
				160	100	160	100	100	100	100	100
Press head height	S mm	240	240	350	350	350	350	400	400	400	400
				350	350	350	350				
Throat depth	C mm	65	65	86	86	86	86	86	86	86	86
Ram bore	Ø mm	10H7	10H7	10H7	10H7	10H7	10H7				
Collet (standard Ø10)	Ø mm							1-17	1-17	1-17	1-17
Hand lever left		o	o	o	o	o	o	●	●	●	●
Angle of rotation/mm stroke		4.1°	4.1°	3.2°	3.2°	3.2°	3.2°	2.2°	2.2°	2.2°	2.2°
Max. weight of the upper tool ²⁾	kg	1.5	1.0	2.5	2.0	2.5	2.0	1.0	1.0	1.0	1.0
Return stroke lock¹⁾											
Minimum working stroke	mm		17		18		18		26		26
Locked position 1	mm bef. BDC		11.5		13		13		19.5		19.5
Locked position 2	mm bef. BDC		3.5		4.5		4.5		7		7
Disengaging accuracy	mm		0.06		0.07		0.07		0.08		0.08
Working height³⁾	F										
Frame No. 13	mm	55-200	55-200								
Frame No. 3	mm			75-220	75-220			120-260	120-260		
Frame No. 2	mm					100-355	100-355			145-360	145-360
Frame No. 2-600 o	mm			200-600	200-600	200-600	200-600	245-650	245-650	245-650	245-650
Frame No. 2-1000 o	mm			330-1030	330-1030	330-1030	330-1030	380-1080	380-1080	380-1080	380-1080
Weight	approx. kg	11	11	22	22	30	30	23	23	31	31

Accessories	5	5R	3	3R	6	6R	1	1R	2	2R
Mechanical counter	o	o	o	o	o	o	o	o	o	o
Throat depth frame (total depth) 111 mm, 131 mm, 160 mm, 200 mm			o	o	o	o	o	o	o	o
Additional fixture mounting plate suitable for throat depth frame			o	o	o	o	o	o	o	o
Micrometer stop	o	o	o	o	o	o				

Frame Overview	Press Type	Frame Height M without height adj. (mm)	Table Size B x T (mm)	Table Bore D (Ø mm)	Table Height K (mm)	Mounting Surface B x L (mm)
No. 13	5	330	110 x 80	20H7	46	110 x 185
No. 3	3, 1	400	150 x 110	20H7	60	150 x 260
No. 2	6, 2	536	185 x 110	20H7	60	185 x 280
No. 2-600	3, 6, 1, 2	810	200 x 160	20H7	98	200 x 290
No. 2-1000	3, 6, 1, 2	1250	200 x 160	20H7	98	200 x 290

Options

- Series with no additional charge o Additional charge applies

¹⁾ Adjustment of locking position on request

²⁾ The weight was determined with hand lever position 45° forward (guide)

³⁾ Typical values; can vary ± 3 mm due to casting and production tolerances

Other available options

- Nickel plated – cast parts are electroless nickel plated, steel components black oxide finished, aluminum anodized, precision steel surfaces are untreated
- Custom paint – press and column can be painted to customer's color specification
- Bores for adapting tooling – customer specific sizes can be supplied

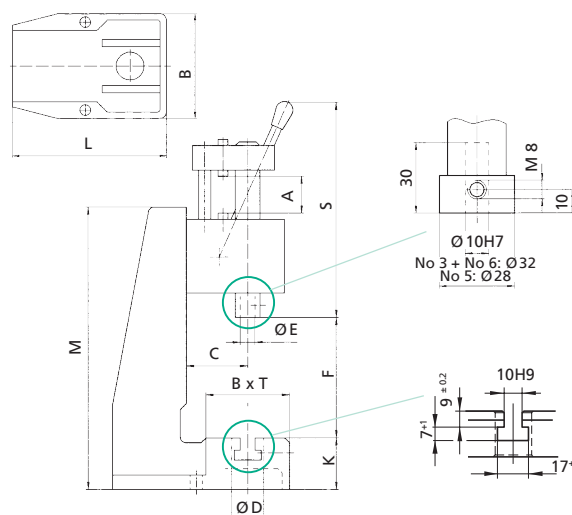
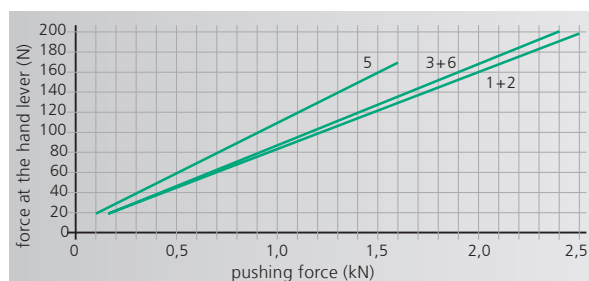

Detailed dimensional drawings can be downloaded: www.schmidttechnology.de

SCHMIDT® Toggle Presses

The high force at the end of stroke, just where it is important

Do you need a high force at the end of stroke for material transforming processes? Then **SCHMIDT® Toggle Presses** are just the right choice.

Characteristics

- High force at the end of stroke (see diagram below)
- Honed bores and ground rams provide a long service life and a precise guidance



Press Type 13RFZ



Press Type 11 / 14 - 17

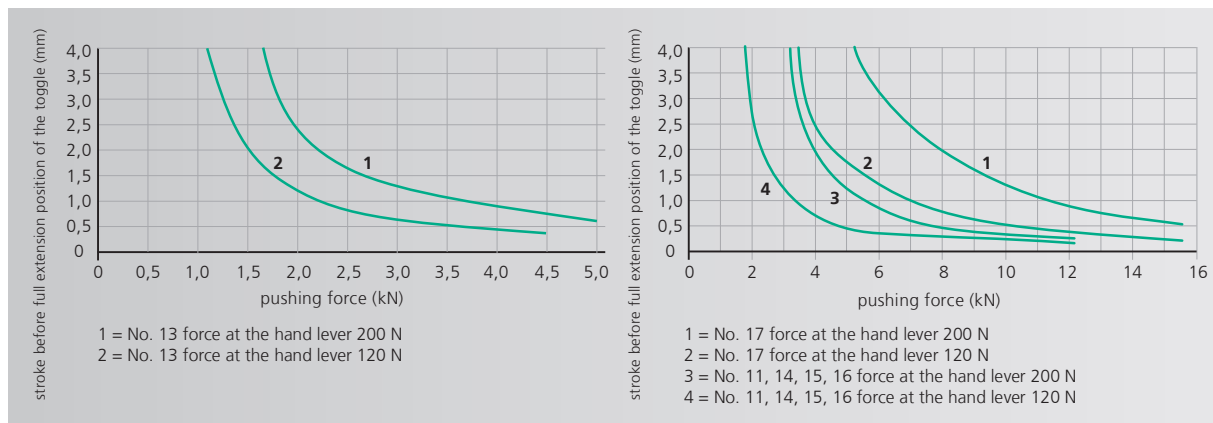

Maximum force will be reached just before extended position

From 5 kN to 15 kN

Press Type		13 13F	13R 13RF	11 11F	11R 11RF	15 15F	15R 15RF	14 14F	14R 14RF	16 16F	16R 16RF	17 17F
Press head type		13-40 13F-35	13R-40 13RF-35	11-45 11F-35	11R-45 11RF-35	11R-45 11F-35	11R-45 11RF-35	11-60 11F-50	11R-60 11RF-50	11-60 11F-50	11R-60 11RF-50	11-20 11F-20
Nominal force	kN	5	5	12	12	12	12	12	12	12	12	15
Working stroke up to	A mm	40 35	40 35	45 35	45 35 ³⁾	45 35 ³⁾	45 35 ³⁾	60 50	60 50	60 50	60 50	20 20 ³⁾
Throat depth	C mm	65	65	86	86	86	86	86	86	86	86	86
Press head height	S mm	385 400	385 400	520 540	520 540	520 540	520 540	500 520	500 520	500 520	500 520	620 640
Ram bore	Ø mm	10H7	10H7	10H7	10H7	10H7	10H7	10H7	10H7	10H7	10H7	10H7
Hand lever left		o		o		o		o		o		
Angle of rotation		95°	95°	110°	110°	110°	110°	125°	125°	125°	125°	90°
Max. weight upper tool ³⁾ standard / reinforced spring	kg	1.2/3.5 1.5/3	1.2/3.5 1.5/3	2/4.5 2.5/6	2/4 2/6	2/4.5 2.5/6	2/4 2/6	1.5/2.5 2/5	1.5/2.5 1.5/4	1.5/2.5 2/5	1.5/2.5 1.5/4	2.5/- 2.5/-
Return stroke lock¹⁾												
Minimum working stroke	mm		25		20		20		24		24	
Locked position 1	mm bef. DC		13.5		12		12		14		14	
Locked position 2	mm bef. DC		1.5		1.5		1.5		1.5		1.5	
Disengaging accuracy	mm		0.03		0.03		0.03		0.04		0.04	
Working height⁴⁾	F mm											
Frame No. 13	mm	65 - 180 40 - 155	65 - 180 40 - 155									
Frame No. 3	mm			75 - 210 50 - 185	75 - 210 50 - 185			90 - 220 65 - 195	90 - 220 65 - 195			65 - 200 50 - 185
Frame No. 5	mm											65 - 315 50 - 300
Frame No. 2	mm					100 - 345 80 - 325	100 - 345 80 - 325			110 - 360 85 - 335	110 - 365 85 - 335	
Frame No. 2-600 O	mm			200 - 585 175 - 560	200 - 585 175 - 560	200 - 585 175 - 560	200 - 585 175 - 560	210 - 595 185 - 570	210 - 595 185 - 570	210 - 595 185 - 570	210 - 595 185 - 570	190 - 575 175 - 560
Frame No. 2-1000 O	mm			330 - 1020 305 - 1000	330 - 1020 305 - 1000	330 - 1020 305 - 1000	330 - 1020 305 - 1000	340 - 1030 315 - 1010	340 - 1030 315 - 1010	340 - 1030 315 - 1010	340 - 1030 315 - 1010	315 - 1015 300 - 1000
Weight	approx. kg	12	12	23	24	29	29	24	24	29	29	23

Accessories		13 13F	13R 13RF	11 11F	11R 11RF	15 15F	15R 15RF	14 14F	14R 14RF	16 16F	16R 16RF	17 17F
Mechanical counter		o	o	o	o	o	o	o	o	o	o	o
Throat depth frame (total depth) 111 mm, 131 mm				o	o	o	o	o	o	o	o	o
Additional fixture mounting plate suitable for throat depth frame				•	•	•	•	•	•	•	•	•
Block clamping piece ²⁾		o	o	•	•	•	•	o	o	o	o	•

Frame Overview	Press Type	Frame Height M (mm)	Table Size B x T (mm)	Table Bore D (Ø mm)	Table Height K (mm)	Mounting Surface B x L (mm)
No. 13	13	475	110 x 80	20H7	46	110 x 185
No. 3	11, 14, 17	540	150 x 110	20H7	60	150 x 260
No. 5	17	536	185 x 110	20H7	60	185 x 275
No. 2	15, 16	700	185 x 110	20H7	60	185 x 280
No. 2-600	11, 14, 15, 16, 17	974	200 x 160	20H7	98	200 x 290
No. 2-1000	11, 14, 15, 16, 17	1410	200 x 160	20H7	98	200 x 290

Options

- Series with no additional charge o Additional charge applies
- ¹⁾ Adjustment of locking position on request
- ²⁾ Stroke reduction about 10 mm by version with additional charge
- ³⁾ The weight was determined with hand lever position 45° forward (guide)
- ⁴⁾ Typical values; can vary ± 3 mm due to casting and production tolerances
- ⁵⁾ Stroke adjustable with stop clamp (in the scope of delivery)

Other available Options

- Nickel plated – cast parts are electroless nickel plated, steel components black oxide finished, aluminum anodized, precision steel surfaces are untreated
- Custom paint – press and column can be painted to customer's color specification
- Bores for adapting tooling – customer specific sizes can be supplied

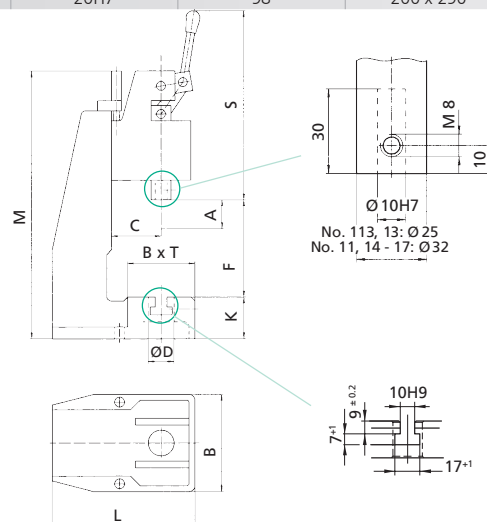

Detailed dimensional drawings can be downloaded: www.schmidttechnology.de

SCHMIDT® Toggle Presses with Horizontal Pull

The high force at the end of stroke, just where it is important

Do you need a high force at the end of stroke for material transforming processes? Then **SCHMIDT® Toggle Presses** are just the right choice.

Characteristics

- High force at the end of stroke (see diagramm below)
- Honed bores and ground rams provide a long service life and a precise guidance



Press Type 113RFZ



Press Type 111RF

Ergonomic Press with horizontal pull

With press No. 113 and No. 111 the manual force is applied by pulling the lever towards the body. This press is especially suitable for rapid production at small forces. We supply press No. 111 including the ergonomic handle (standard scope of supply).

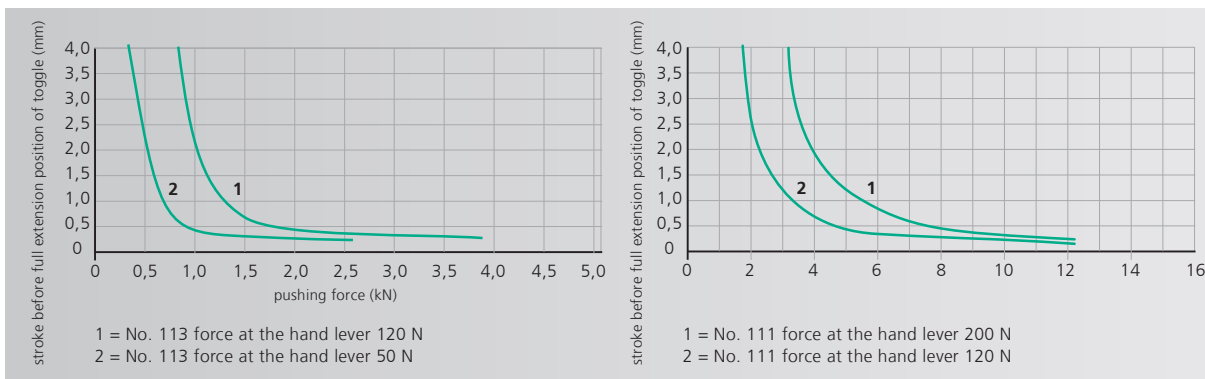

Maximum force will be reached just before extended position

From 2.5 kN to 12 kN

Press Type			113 113F	113R 113RF	111 111F	111R 111RF
Press head type			113 113F	113R 113RF	111 - 45 111F - 50	111R - 45 111RF - 50
Nominal force		kN	2.5	2.5	12	12
Working stroke up to ⁵⁾	A	mm	28 28	28 28	45 50	45 50
Throat depth	C	mm	65	65	86	86
Press head height	S	mm	170 180	190 200	215 225	240 250
Ram bore	Ø	mm	10H7	10H7	10H7	10H7
Hand lever left			-	-	-	-
Angle of rotation			80°	80°	90°	90°
Max. weight upper tool ³⁾ standard / reinforced spring		kg	1/3 0.6/3	0.5/2.5 0.6/3	2.5/- 3/-	2.5/- 3/-
Return stroke lock¹⁾						
Minimum working stroke		mm		22		24
Locked position 1		mm bef. BDC		12		14
Locked position 2		mm bef. BDC		0.5		1.5
Disengaging accuracy		mm		0.03		0.07
Working height⁴⁾	F					
Frame No. 13		mm	50 - 165 40 - 155	50 - 165 40 - 155		
Frame No. 3		mm			120 - 205 105 - 195	120 - 205 105 - 195
Frame No. 2		mm			120 - 345 105 - 335	120 - 345 105 - 335
Frame No. 2-600 ○		mm			200 - 580 185 - 570	200 - 580 185 - 570
Frame No. 2-1000 ○		mm			330 - 1020 310 - 1000	330 - 1020 310 - 1000
Weight		approx. kg	11	11	28	28

Accessories	113 113F	113R 113RF	111 111F	111R 111RF
Mechanical counter	○	○	○	○
Throat depth frame (total depth) 111 mm, 131 mm			○	○
Additional fixture mounting plate suitable for throat depth frame			○	○
Block clamping piece ²⁾	● ○	● ○	● ○	● ○

Frame Overview	Press Type	Frame Height M (mm)	Table Size B x T (mm)	Table Bore D (Ø mm)	Table Height K (mm)	Mounting Surface B x L (mm)
No. 13	113	475	110 x 80	20H7	46	110 x 185
No. 3	111	540	150 x 110	20H7	60	150 x 260
No. 2	111	700	185 x 110	20H7	60	185 x 280
No. 2-600	111	974	200 x 160	20H7	98	200 x 290
No. 2-1000	111	1410	200 x 160	20H7	98	200 x 290

Options

- Series with no additional charge ○ Additional charge applies
- ¹⁾ Adjustment of locking position on request
- ²⁾ Stroke reduction about 10 mm by version with additional charge
- ³⁾ The weight was determined with hand lever position 45° back (guide)
- ⁴⁾ Typical values; can vary ± 3 mm due to casting and production tolerances
- ⁵⁾ Stroke adjustable with stop clamp (in the scope of delivery)

Other available options

- Nickel plated – cast parts are electroless nickel plated, steel components black oxide finished, aluminum anodized, precision steel surfaces are untreated
- Custom Paint – Press and column can be painted to customer's color specification
- Bores for adapting tooling – customer specific sizes

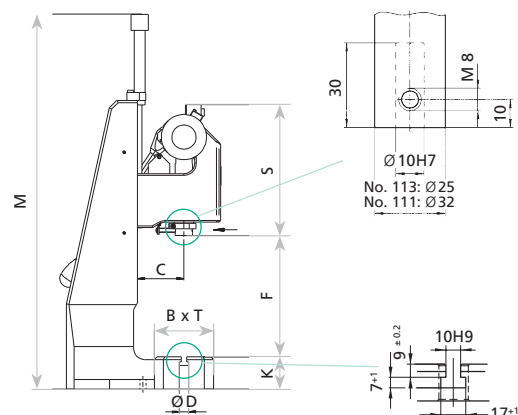
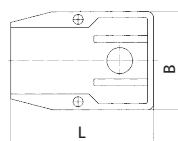

Detailed dimensional drawings can be downloaded: www.schmidttechnology.de

SCHMIDT® Toggle Presses with Square Ram

Optimum guidance and anti-rotation

Do you need a high force at the end of stroke for material-transforming processes? Then **SCHMIDT® Toggle Presses** are just the right choice.

Characteristics

- High force at the end of stroke
- Square ram is anti-rotational (no die sets required)
- Fully adjustable, play-free teflon-lined gibs



Press Type 11 VRFZ
13 VRFZ
14 VRFZ

Press Type 15 VF
16 VF

Press Type 19 VF

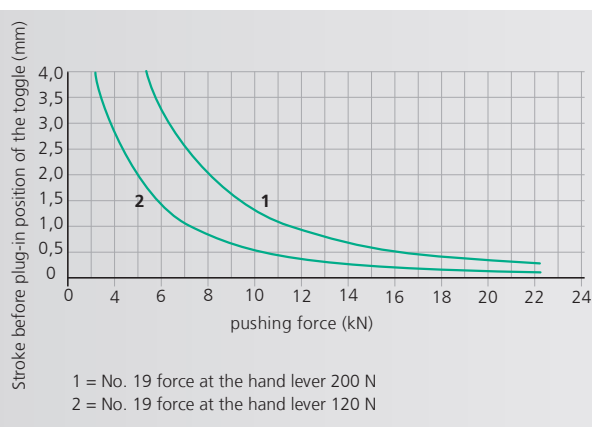
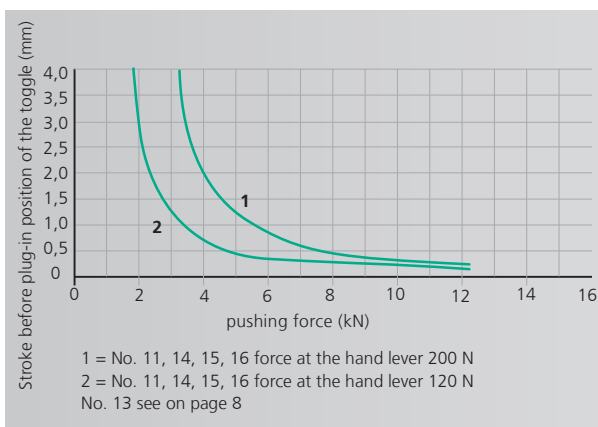

Maximum force will be reached just before extended position

From 5 kN to 22 kN

Press Type		13 V 13 VF	13 VR 13 VRF	11 V 11 VF	15 V 15 VF	11 VR 11 VRF	15 VR 15 VRF	14 V 14 VF	16 V 16 VF	14 VR 14 VRF	16 VR 16 VRF	19 V 19 VF	19 VR 19 VRF
Press head type		13V-40 13VF-40	13VR-40 13VRF-40	11V-45 11VF-45	11V-45 11VF-45	11VR-45 11VRF-45	11VR-45 11VF-45	11V-60 11VF-60	11V-60 11VF-60	11VR-60 11VRF-60	11VR-60 11VRF-60	19V-40 ¹⁾	19VR-40 ¹⁾
Nominal force	kN	5	5	12	12	12	12	12	12	12	12	22	22
Working stroke up to ⁵⁾	A mm	40 40	40 40	45 45	45 45	45 45	45 45	60 60	60 60	60 60	60 60	40 40	40 40
Throat depth	C mm	65	65	86	86	86	86	86	86	86	86	131	131
Press head height	S mm	385 400	385 400	510 530	510 530	510 530	510 530	510 530	510 530	510 530	510 530	620 620	620 620
Ram bore	Ø mm	10H7	10H7	10H7	10H7	10H7	10H7	10H7	10H7	10H7	10H7	20H7	20H7
Hand lever left		o		o	o			o	o			•	•
Angle of rotation		95°	95°	110°	110°	110°	110°	125°	125°	125°	125°	175°	175°
Max. weight upper tool ³⁾ standard / reinforced spring	kg	1.2/4 2/3.5	1.2/4 2/3.5	1.6/4.2 2/5	1.6/4.2 2/5	1.6/4.2 2/5	1.6/4.2 2/5	1/3.5 1/3.5	1/3.5 1/3.5	1/3.5 1/3.5	1/3.5 1/3.5	2/- 2/-	2/- 2/-
Return stroke lock²⁾													
Minimum working stroke	mm		26			20	20				28	28	10
Locked position 1	mm bef. BDC		14.5			12	12				14	14	4.5
Locked position 2	mm bef. BDC		1.5			1.5	1.5				1.5	1.5	0.9
Disengaging accuracy	mm		0.03			0.03	0.03				0.04	0.04	0.02
Working height⁴⁾	F												
Frame No. 13	mm	65-180 50-165	65-180 50-165										
Frame No. 3	mm			80-210 60-190		80-210 60-190		80-210 60-190		80-210 60-190			
Frame No. 2	mm				105-350 85-330		105-350 85-330		105-350 85-330		105-350 85-330		
Frame No. 2-600 o	mm				200-585 185-570		200-585 185-570		210-590 195-575		210-590 195-575		
Frame No. 2-1000 o	mm				330-1020 315-1000		330-1020 315-1000		340-1030 325-1015		340-1030 325-1015		
Frame No. 19	mm											90-220	90-220
Frame No. 19-400 o	mm											160-400	160-400
Frame No. 19-500 o	mm											260-550	260-550
Weight	approx. kg	12	12	24	32	24	32	24	32	24	32	85	85
Accessories		13 V 13 VF	13 VR 13 VRF	11 V 11 VF	15 V 15 VF	11 VR 11 VRF	15 VR 15 VRF	14 V 14 VF	16 V 16 VF	14 VR 14 VRF	16 VR 16 VRF	19 V 19 VF	19 VR 19 VRF
Mechanical counter		o	o	o	o	o	o	o	o	o	o	o	o
Throat depth frame 111 mm, 131 mm				o	o	o	o	o	o	o	o		
Throat depth frame 151 mm												o	o
Additional fixture mounting plate suitable for throat depth frame				o	o	o	o	o	o	o	o	o	o
Frame Overview	Press Type	Frame Height M (mm)		Table Size B x T (mm)		Table Bore D (Ø mm)		Table Height K (mm)		Mounting Surface B x L (mm)			
No. 13	13	475		110 x 80		20H7		46		110 x 85			
No. 3	11, 14	540		150 x 110		20H7		60		150 x 260			
No. 2	15, 16	700		185 x 110		20H7		60		185 x 280			
No. 2-600 o	15, 16	974		200 x 160		20H7		98		200 x 290			
No. 2-1000 o	15, 16	1410		200 x 160		20H7		98		200 x 290			
No. 19	19	640		200 x 160		25H7		112		200 x 370			
No. 19-400 o	19	840		250 x 200		40H7		145		250 x 460			
No. 19-500 o	19	1000		250 x 200		40H7		145		250 x 480			

Options

- Series with no additional charge o Additional charge applies
- ¹⁾ Special strokes 12 mm and 50 mm on request
- ²⁾ Adjustment of locking position on request
- ³⁾ The weight was determined with hand lever position 45° forward (guide)
- ⁴⁾ Typical values; can vary ± 3 mm due to casting and production tolerances
- ⁵⁾ Stroke adjustable with stop clamp (in the scope of delivery)
- ⁵⁾ Adjustable stroke

Other available options

- Nickel plated – cast parts are electroless nickel plated, steel components black oxide finished, aluminum anodized, precision steel surfaces are untreated
- Custom Paint – Press and column can be painted to customer's color specification
- Bores for adapting tooling – customer specific sizes

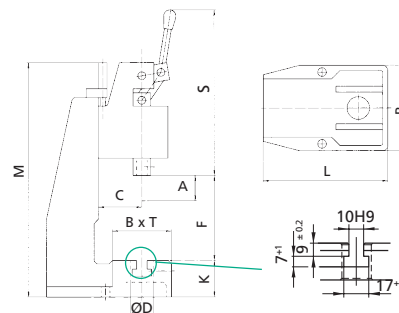

Detailed dimensional drawings can be downloaded: www.schmidttechnology.de

SCHMIDT® CamPress 11N

The best of both worlds

We have merged the best features of the two hand lever press types, the toggle press and the rack and pinion press, and combined them in the **SCHMIDT® CamPress 11N**. Thanks to this clever mechanism, the patented assembly press is characterized by a particularly smooth operation and strong force at the end of the stroke. The sophisticated mechanics make the manual CamPress 11N particularly ergonomic and user-friendly.

This unique motion creates a high, linear force progression with high breakaway torque at the beginning of the ram movement and a steep force increase at the end of the stroke; and all this with constant hand force.

The use of the balance weights and the ErgoHandle ensures a smooth motion process and ergonomic operation of the hand lever. Both components and height adjustment with the crank lever are part of the standard scope of delivery. Of course, the proven options such as return stroke lock, fine adjustment and mechanical counter can also be used here.

SCHMIDT® CamPress 11N
with return stroke lock and
fine adjustment



Balance weight and
ErgoHandle for
ergonomic operation
of the hand lever

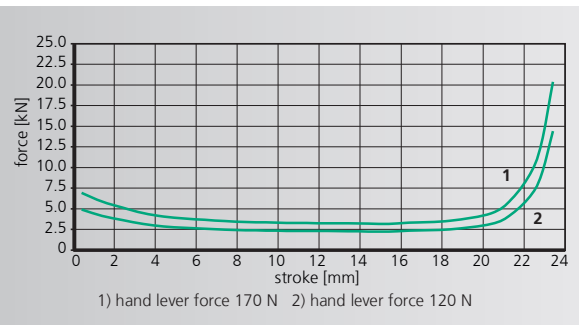

SCHMIDT® CamPress 11N

Examples of process-safe workstations

Press Typ		11N 11NF
Press head type		11N-23 11NF-23
Nominal force	kN	20
Working stroke up to	A mm	23 23
Throat	C mm	86
Head height	S mm	458 481
Ram bore	Ø mm	10H7
Hand level left		
Rotation angle / stroke	°	180
Max. weight upper tool ³⁾	kg	2
Return stroke lock ²⁾		
Minimum working stroke	mm	10.3
Locked position 1	mm bef. BDC	12.7
Locked position 2	mm bef. BDC	1.8
Disengaging accuracy	mm	0.05
Working height ⁴⁾	F mm	
Frame No 5	mm	75 – 320 55 – 300
Weight	~ kg	40
Option		11N 11NF
Mechanical counter		○

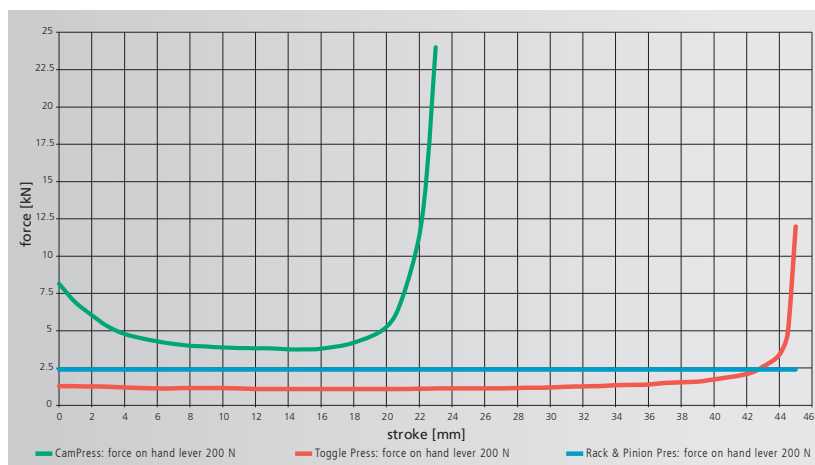

CamPress 11N in comparison to Toggle Press and Rack and Pinion Press

Frame	Press Typ	Frame height M (mm)	Table size B x T (mm)	Table bore D (Ø mm)	Table height K (mm)	Footprint B x L (mm)
No. 5	11N	587	185 x 110	20 ^{H7}	60	185 x 273

Options

- Series with no additional charge ○ Additional charge applies
- ²⁾ Adjustment of locking position on request
- ³⁾ The weight was determined with hand lever position 45° forward (guide)
- ⁴⁾ Typical values; can vary ± 3 mm due to casting and production tolerances

Other available options

- Nickel plated – cast parts are electroless nickel plated, steel components black oxide finished, aluminum anodized, precision steel surfaces are untreated
- Custom paint – press and column can be painted to customer's color specification
- Bores for adapting tooling – customer specific sizes

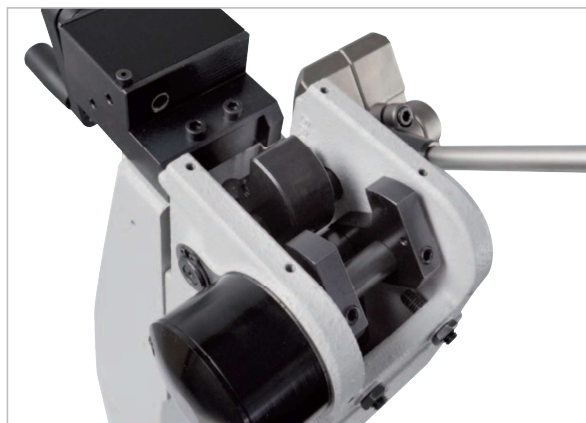

Patented mechanics with high force at the end of the stroke

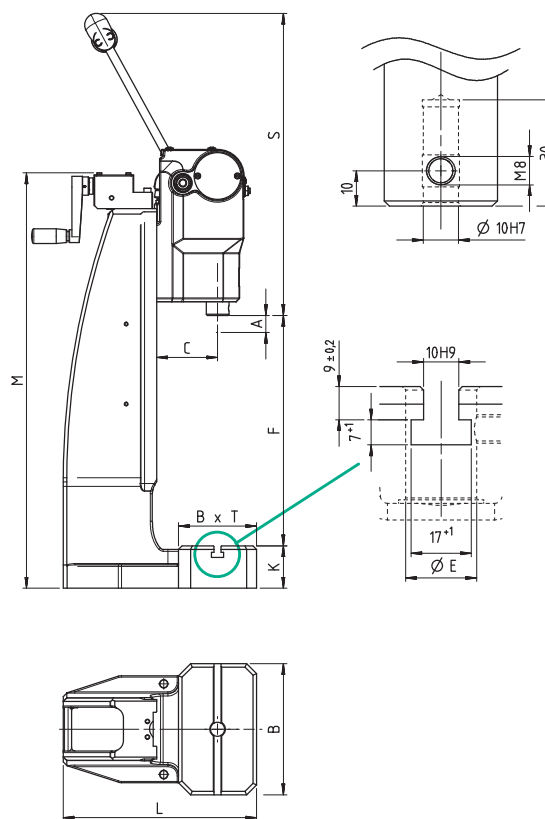

SCHMIDT® DuplexPress 8

With minimal effort of 0,12 kN a high force of 7 kN

The **SCHMIDT®** DuplexPress 8 breaks new ground for familiar hand lever presses with a completely new operating principle. The challenge of achieving high forces (7 kN) with long strokes (up to 140 mm) is not possible either with conventional rack and pinion or toggle presses. Thus this new developed press represents a very universal solution for pressing tasks, which can also be used extremely ergonomically with low hand force (120 N).

The left hand lever actuates the approach stroke to position the ram quickly to the workpiece.

The right hand crank activates the power stroke any time with little manual force. The transmission ratio of the planetary gear-box achieves a high effective force on the ram. This is useful, for example, when a long stroke has to be covered before reaching the component where the high forces of the press are required.

Why compressed air?

Why does the press have a compressed air connection or an accumulator?

The compressed air retracts the ram back to the TDC (top dead center) with constant force and speed. In addition, the speed can be individually adjusted with the pressure regulator, this pneumatic driven return stroke increases the ergonomic compared to a conventional spring solution. In addition, the two-chamber design of the tank ensures that the weight of the upper tool can be compensated via the adjustable differential pressure.

The version with pressure tank is available for self-sufficient and maximum energy-efficient operation of the press. Thanks to the intelligent re-storage of compressed air, the loss of compressed air is minimised and it is sufficient to fill the tank about once a week. Alternatively, the press can also be connected directly to the compressed air supply.

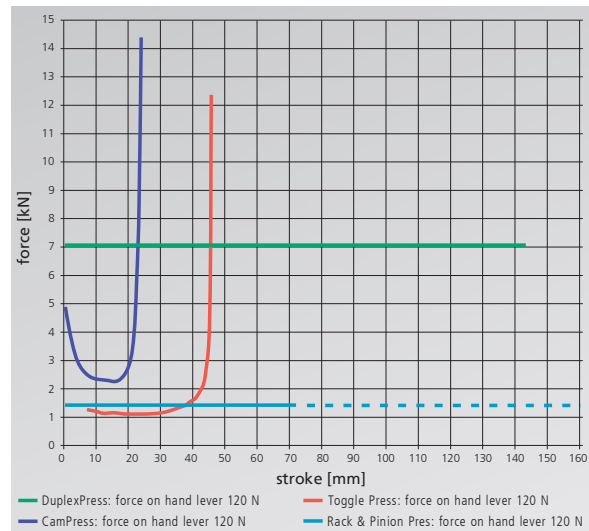

DuplexPress in comparison to Toggle Press, Rack and Pinion Press or CamPress 11N

SCHMIDT® DuplexPress 8

A long stroke of 140 mm and super ergonomic operation

Press Typ			8
Nominal force		kN	7
Working stroke	A	mm	140
Throat	C	mm	86
Head height	S	mm	446
Ram bore	Ø	mm	10 ^{H7}
Max. force at crank (power stroke)		N	120
Max. weight upper tool ²⁾		kg	5
Working height ⁴⁾	F	mm	35 – 285
Height adjustment			series
Head weight 8RDS		approx. kg	19.5
Mechanical counter			series
Return stroke lock for 8R, 8RD, 8RS, 8RDS ²⁾			
Minimum working stroke		mm	120.4
Locked position 1 (bef. BDC)		mm	19.6
Locked position 2 (bef. BDC)		mm	6.8
Disengaging accuracy		mm	± 0.04
Max. operating pressure			
Network operation		bar	6
Storage module (self-sufficient operation)		bar	8

Frame	Frame height M (mm)	Table size B x T (mm)	Table bore D (Ø mm)	Table height K (mm)	Footprint B x L (mm)	Weight kg
No. 5	536	110 x 80	20 ^{H7}	60	110 x 185	26
No. 2-600	974	200 x 160	20 ^{H7}	98	200 x 290	52

²⁾ Adjustment of locking position on request

⁴⁾ Typical values; can vary ± 3 mm due to casting and production tolerances

Other available options

- Custom paint – press and column can be painted to customer's color specification
- Bores for adapting tooling – customer specific sizes



DuplexPress 8 R (S)



DuplexPress 8 D (S)



DuplexPress 8 RD (S)



DuplexPress 8

Nomenclature

- R = Return stroke lock
- D = Duplex (rapid approach stroke)
- S = Storage module (self-sufficient operation)



DuplexPress 8 S

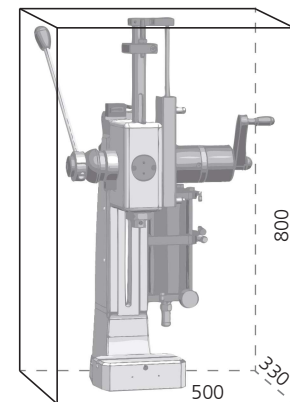

Volume dimensions with frame no. 5

SCHMIDT® ManualPress

Options suitable for your application

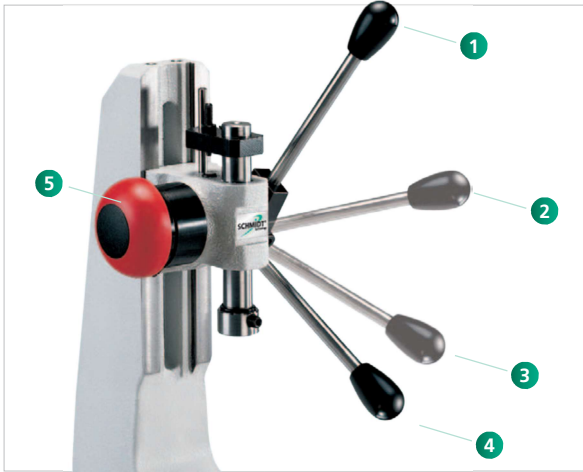

The return stroke lock guarantees reaching the required pressing depth with every stroke

- 1 TDC (Top Dead Center) position
- 2 First locking position: Loose tools can still be aligned
- 3 Second locking position before BDC (Bottom Dead Center). From here you can only continue to BDC.
- 4 After reaching BDC (Bottom Dead Center) and completing the stroke the return stroke lock is released. This guarantees a repeatable BDC and thus a constant press depth
- 5 The emergency button releases the locking function in any position



Fine adjustment with micrometer scale serves as stop for the rack and pinion presses

An optional micrometer adjustable stop developed specifically for applications that need fine adjustment of the BDC. The robust and precise design ensures the repeatability of the stop, no matter how many strokes are taken.



Fine adjustment with micrometer scale for toggle presses

By loosening the set screw 1 and turning the adjusting nut 2 with the same tool, the setting of the BDC can be adjusted infinitely. The adjustment in a range of $\frac{1}{100}$ of a mm is reached rapidly and precisely.

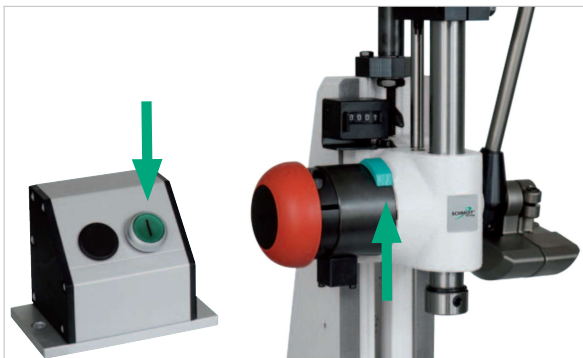

Stroke-Release Manual Presses – for more Safety

Monotonous, manually operated press applications can potentially become a source of danger with serious injuries. The remedy is to equip our manual presses with clever mechanics. This turns them into safety devices with 2-hand operation for ram movement.

The stroke release is achieved by disengaging the locking mechanism with one hand; now the 2nd hand can operate the hand lever. Alternatively, the locking mechanism can be unlocked by a button.

SCHMIDT® ManualPress

Options suitable for your application



Mechanical counter
A four digit counter monitors the number of pieces produced. The counter is provided with a reset function.



Collet
For the rack-and-pinion presses No. 1 and No. 2, collet bore diameter of 1 to 17 mm.



Throat extension block
We offer various sizes for extended throat depths.



Special fixture mounting plates
Special fixture tabletops, designed in conjunction with throat extension blocks, provide ram to table bore alignment when spacer is used.



Ergonomic left-handed design
With most press types, lefthanded or left-/right-handed design is an available option.



Upper tooling adapter
Adapter for tools with a diameter of 5 - 20 mm.



Nickel plated design
Press frames and cast parts are electroless nickel-plated, steel components are black oxide finished, aluminum parts are anodized, precision steel surfaces are untreated.



Ergonomic handle
Swivelling handle for improved comfort; easy and flexible assembly on the hand lever.



Press base
Plastic (250 x 340 mm), including fasteners.



Stop clamp
For Toggle Presses.

How to order

Order key for press options

R = incl. return stroke lock with emergency release
F = incl. fine adjustment with micrometer scale
Z = incl. mechanical counter
RF= incl. return stroke lock with emergency release and fine adjustment
D= duplex (rapid approach stroke)
S = storage module (self-sufficient operation)

Order example

No. 3 R = **SCHMIDT® Rack-and-Pinion Press No. 3**
incl. return stroke lock with emergency release
or
No. 13 RFZ = **SCHMIDT® Toggle Press No. 13**
incl. return stroke lock with emergency release,
fine adjustment and mechanical counter