



**SAG·Tek**

# POLISHING PERFECTION

Powered by **your CNC**



Pre-polish



Post-polish



# 1. INTRODUCTION



The manufacturing industry has made use of computer numerical control (CNC) machining since the 1950s. This drastically increases the complexity and quality of components our modern world requires. As machining tolerances have improved, so too has the surface finish requirements - yet polishing technology has not kept up with industry and polishing parts by hand is still the norm. SAG-Tek offers a tooling solution that will bring high quality polishing to your CNC platforms.

Shape Adaptive Grinding (SAG) was developed to couple the high removal rates of traditional grinding tools with the surface finish capabilities of polishing tools. The full range of SAG tools brings support for all manner of complex geometries, whilst offering high material removal rates and optical-quality surface finishes.

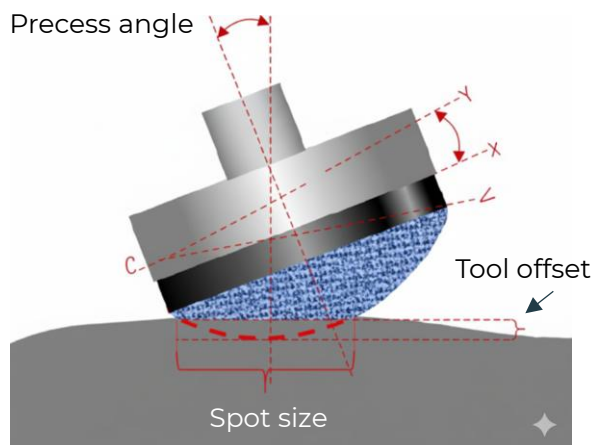

- Remove machining marks
- Achieve mirror-like surface finishes
- Suitable for a wide range of materials
- Compatible with almost all machining platforms
- Reduce production cycle time
- Reduce labour requirements
- Eliminate expensive part-specific tooling
- Reduce scrap rates
- Increase shopfloor space utilisation
- Ideal for Lean and Agile production

SAG is comprised of:

- Bonded diamond abrasive
  - Nickel Bonded Diamond (NBD)
  - Resin Bonded Diamond (RBD)
- Flexible rubber layer
- Stainless steel tool stem

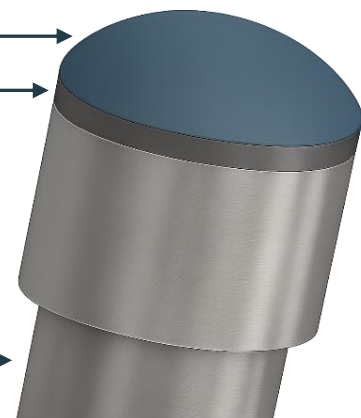

SAG offers an innovative solution for both grinding and polishing surfaces within the same operation. SAG achieves surface finishes that compete with or surpass traditional finishing processes. With effective material removal, SAG is ideal for removing machine marks on the surface whilst actively improving the surface roughness. Eliminating the need for many different traditional finishing operations.

Comparison of conventional and shape adaptive grinding

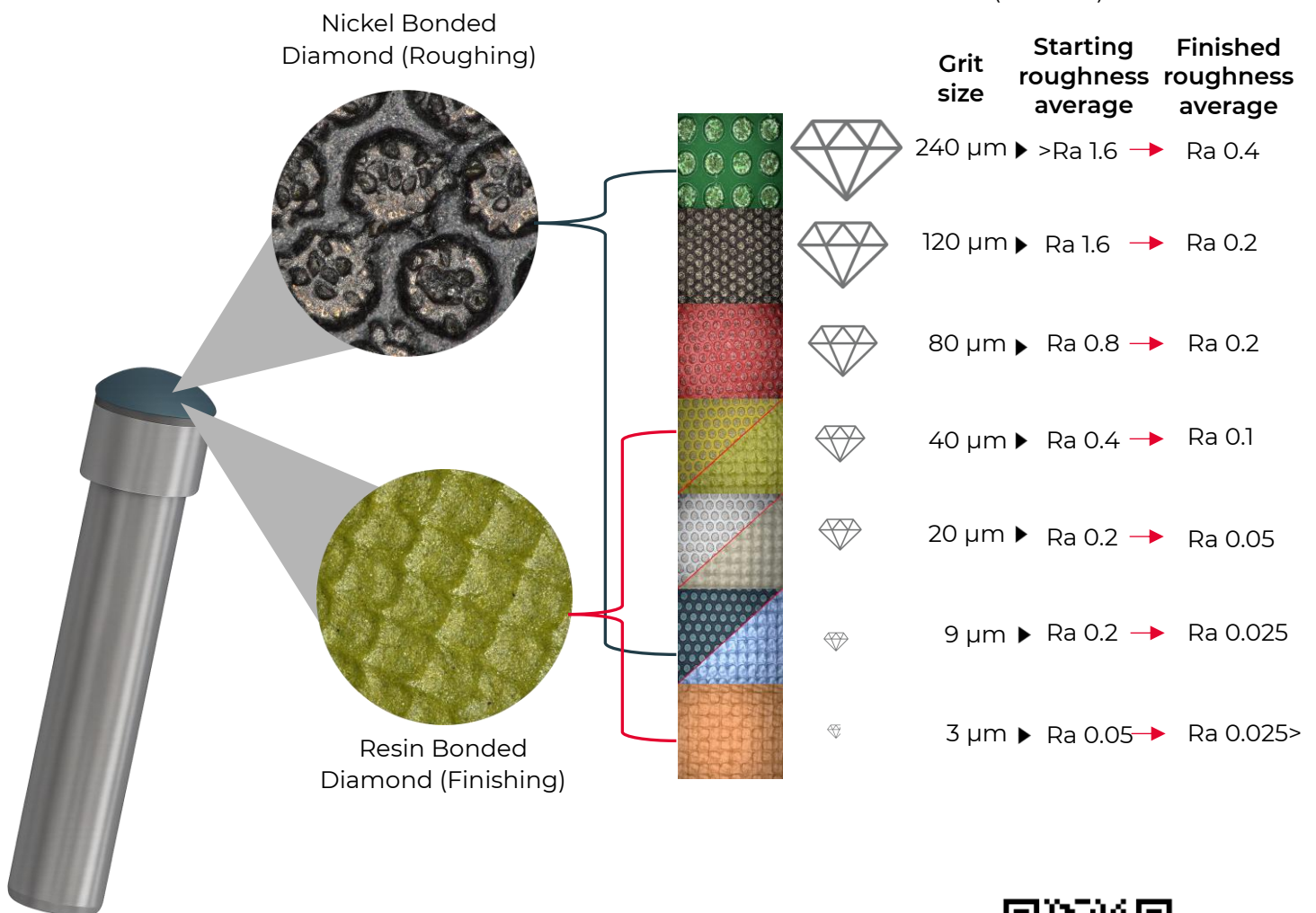
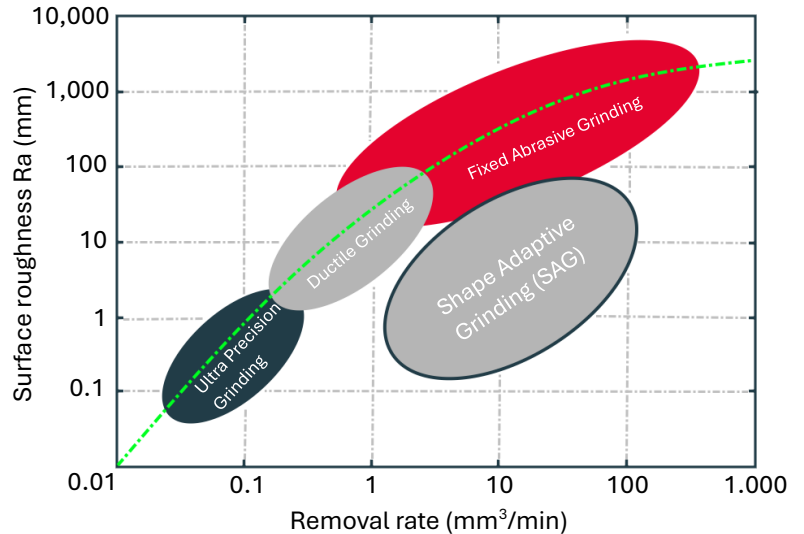

Check out the SAG-Tek YouTube channel



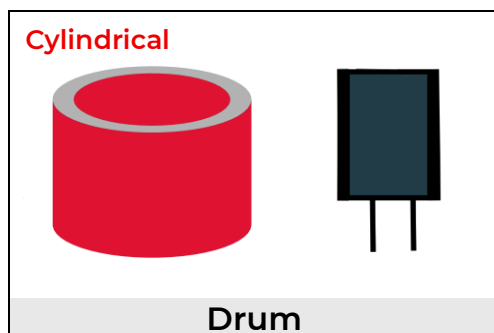
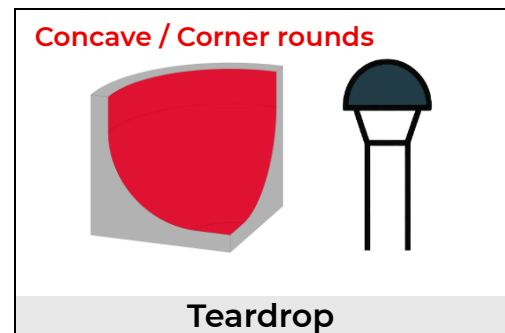
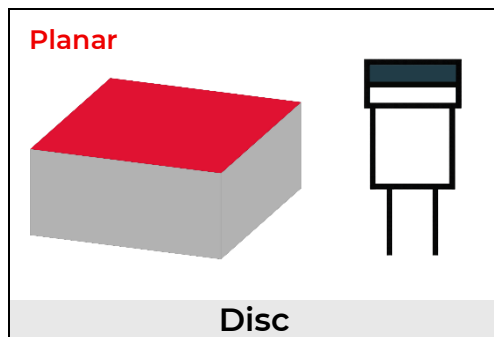
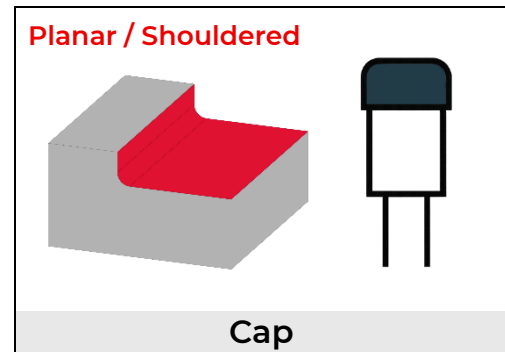
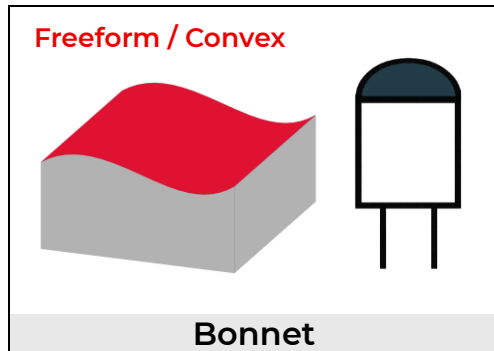

- 50+ tools to choose from
- 5 key tool geometries
- Support for special projects
- Online and onsite training
- 24/7 customer support

- The standard hardness SAG tools are optimised for delivering a great surface finish on CNC or our RPC system.
- Our Supersoft tools are perfect for parts with large manufacturing tolerances (where the geometry doesn't match the CAD), for example, metal 3D printed parts. The soft rubber can adsorb up to 3 mm of surface deviation.

Explore the full SAG-Tek range on our website



Unsure about how our tools can be used on your parts? Contact our team of experts: +44 1530 432 590 | [info@sag-tek.co.uk](mailto:info@sag-tek.co.uk) | [www.sag-tek.co.uk](http://www.sag-tek.co.uk)

# 3. TECHNICAL DATA



SAG tool operation requirements:

- 3, 4, 5 or 5 axis systems
- 12 mm tool holding capability
- CAM Software
- Cutting Coolant - suitable for the workpiece

Recommended polishing parameters			Tools should be cleaned regularly using an alcohol-based solution and lint-free cloth		
Material	Diamond bond method	Spindle speed (RPM)	Feed rate (mm/min)	Offset (mm)	Material removal depth (µm)
Mild steel	Roughing (NDB)	8,000	1,000	0.2	20 – 5
	Finishing (RDB)	8,000	1,000	0.3	3 – 1
Stainless steel	Roughing (NDB)	6,000	800	0.2	18 – 4
	Finishing (RDB)	6,000	800	0.3	3 – 1
Cobalt chrome	Roughing (NDB)	3,000	1,000	0.3	15 – 3
	Finishing (RDB)	3,000	1,000	0.3	3 – 1
*Titanium	Roughing (NDB)	1,300	4	0.3	10 – 2
	Finishing (RDB)	2,500	4	0.3	2 – 1
Titanium 64	Roughing (NDB)	6,000	800	0.35	15 – 5
	Finishing (RDB)	6,000	800	0.35	4 – 1
Silicon carbide	Roughing (NDB)	1,000	500	0.15	10 – 5
	Finishing (RDB)	6,000	800	0.15	4 – 1
Aluminium	Roughing (NDB)	16,000	2,000	0.1	10 – 2
	Finishing (RDB)	16,000	2,000	0.1	2 – 1
Inconel	Roughing (NDB)	6,000	800	0.2	15 – 4
	Finishing (RDB)	6,000	1,200	0.3	4 – 1

\*Concave surfaces, for example a Hip Cup.

These parameters are recommended nominals for their respective materials. The parameters can be modified to optimize specific factors.

**Example:** Increasing feed rate improves the cycle time but decreases the tool life span, surface finish, and material removal.

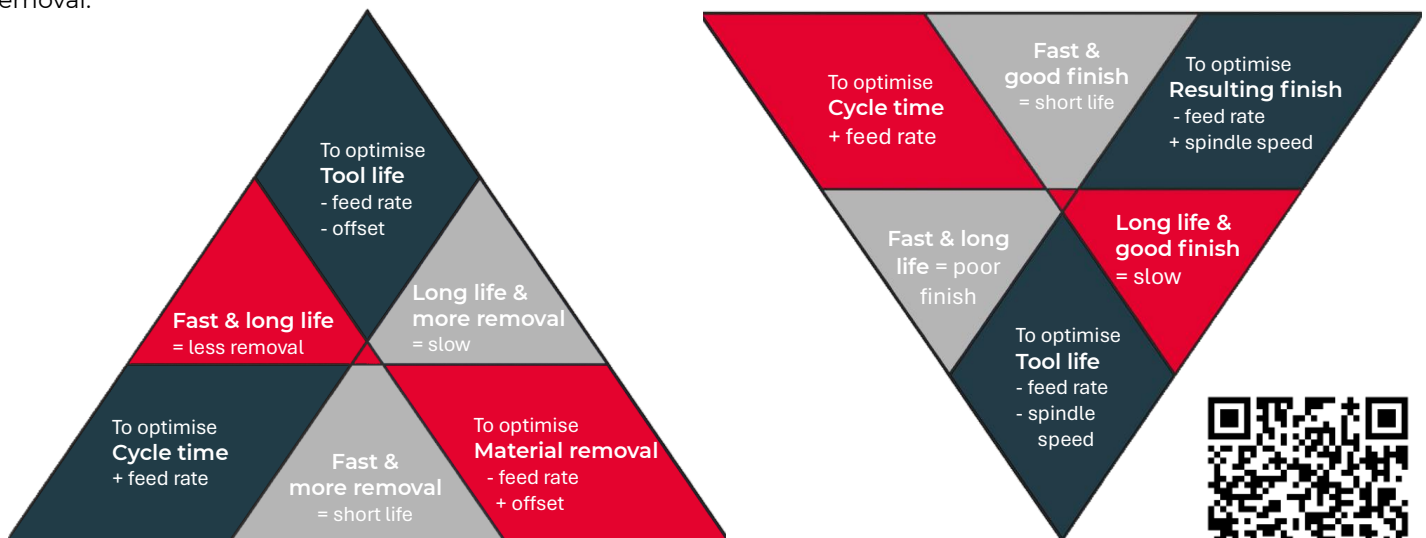

For **Track Spacing (Step Over)** use our online calculator available at: <https://sag-tek.co.uk/Track-Spacing-Spot-Size-Calculator> or scan the QR code.





# SAG·Tek

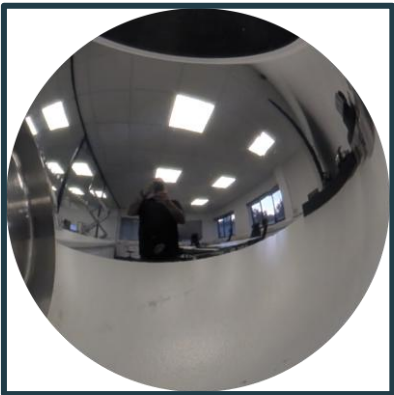

+44 1530 432590

[info@sag-tek.co.uk](mailto:info@sag-tek.co.uk)

[www.sag-tek.co.uk](http://www.sag-tek.co.uk)

2 Garden Court, Gee Rd,  
Coalville, Leicestershire,  
LE67 4NB,  
United Kingdom.