

Valk Welding Group

Tel +31 78 69 170 11
info@valkwelding.com
www.valkwelding.com



Your future
in welding



The strong connection



See our video

Your future in welding

The industry is undergoing a transition. Innovations are coming thick and fast, and companies have more opportunities than ever to make their production smarter, safer, and more sustainable. There are also plenty of opportunities in the field of welding. Where craftsmanship and precision have always been key, robot welding now offers the opportunity to combine these values with speed, consistency, and flexibility. It enables companies to improve their quality, optimise their processes and respond better to a changing market.

Consistent welding quality, regardless of availability

Robotic welding delivers consistent, high-quality results—regardless of batch size or time of day. Unlike manual welding, which relies on the skill and availability of experienced workers, automation ensures precision and repeatability every time.

Greater safety and better ergonomics in the workplace

Risky or unhealthy tasks are taken over by robots. This not only reduces the risk of accidents at work but also improves working conditions for employees.

Lower costs through higher efficiency

With fewer breakdowns, less reworking and higher productivity, a welding robot can contribute to a structurally lower cost price per product. Investments pay for themselves through a more stable and efficient production process.

Flexible response to changing production demand

Modern welding robots are quick to set up and suitable for a wide range of series and product configurations. This enables agile production without compromising on quality or lead times.

Solution for the shortage of skilled workers

The availability of experienced welders is declining. Robot welding offers a scalable solution that guarantees production capacity, even when there are staff shortages. This ensures continuity.

Automated welding is not a replacement for craftsmanship, but a way to enhance it. Companies that invest in this are building a production environment that is ready for tomorrow's challenges.

Automated welding is not a replacement for craftsmanship, but a way to enhance it.

01 Welding technology	4
02 The robot	8
03 The configuration	12
04 Software	30
05 Welding wire	34

Valk Welding provides the certainty of the right choice because a weld is more than just a connection.

01

Leading in welding technology

A weld is never just a connection. It is a decisive factor in the safety, functionality, and appearance of a product. Whether it concerns constructions that must meet strict standards or visible seams that must be aesthetically perfect, the quality of the weld makes all the difference.

That is why every successful automation project starts with the right choice of welding process. This choice is not a technical detail, but a strategic decision that has a direct impact on product quality, lead time and reliability.

Valk Welding acts as a compass in this process selection. We bring in-depth knowledge of welding technology, years of practical experience and a strong focus on collaboration. We not only help customers choose the right welding process, but also implement it successfully within their production environment.

With this combination of technology and dedication, we work together to build a process in which the weld delivers the strength, quality and appearance that your product requires. To respond to your future needs, Valk Welding has expanded its expertise in arc welding to include laser welding and plastic welding. These techniques offer new possibilities in terms of precision, material selection and process optimisation. This means that we not only keep up with the times, but also actively innovate with the future of welding.



TAWERS TIG

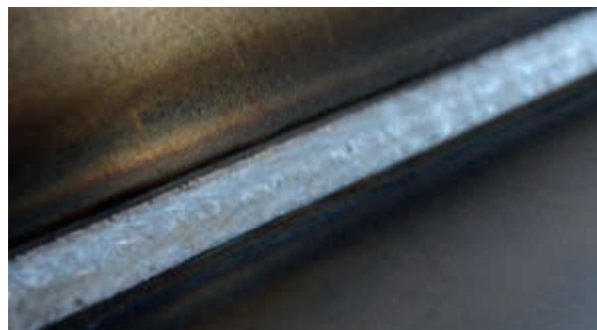

SP-MAG process



Hyper Dip Pulse process



Zi-Tech process

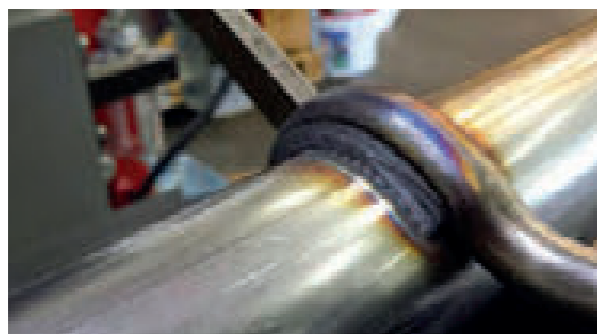

HD-MAG welding process

Arc welding process

Panasonic is constantly working on the development of advanced welding processes. The aim is to offer the most suitable welding process for every application and every material. We collaborate with you to achieve the best result.

The unique fusion of robot, robot control, power source and servo wire feed in a single device offers unrivalled advantages. This technology is faster and better, and everything comes from a single manufacturer. TAWERS Fusion technology integrates the robot control with the welding power source control, combining all control parameters in a single device. This ensures 250 times faster communication, eliminating delays in the flow of information between the individual components.

The welding robots are equipped with various standard functions that optimise the process. These include an automatic restart function in case of start failure, a torch angle display for uniform welding, and a flying start function to reduce cycle times. In addition, there is an automatic wire retraction function for a perfect start at the next seam and weld navigation that serves as a guide for the perfect welding parameters. Stitch welding and LowPulse welding are also possible.

In addition to the standard features, Panasonic offers a range of other interesting options. These include the Panasonic HD Mag process for stainless steel and functions for Stitch Pulse and Pulse Mix welding. This ensures that your welding work is of the highest quality and meets all the requirements and regulations of your industry.

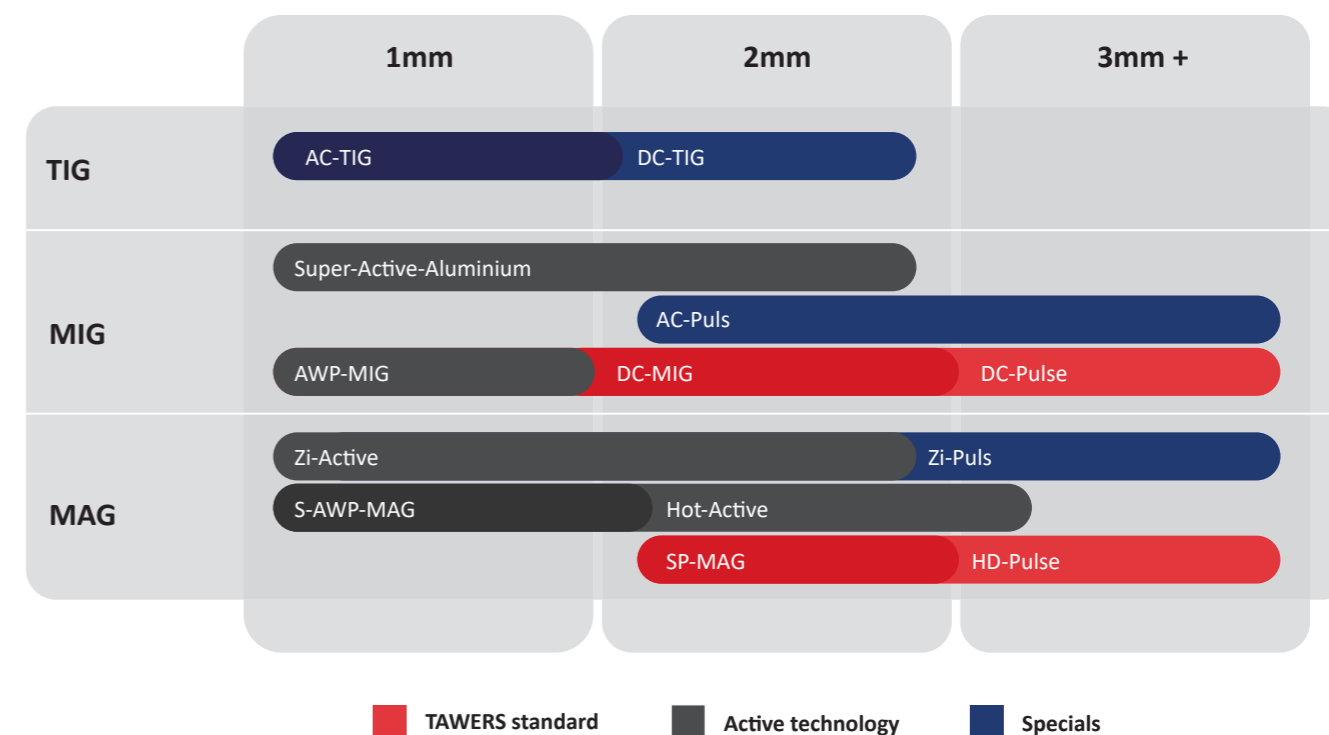

Laser welding

Valk Welding offers a completely safe CE solution for your employees, optimal performance, and welding quality through 100% integration, and the option of welding with or without filler material. Offline programming ensures a shorter ROI. In addition, Valk Welding offers complete peace of mind with service support and, if desired, a solution including welding jigs.

The combination of a powerful laser, advanced optics and efficient cooling makes the Valk Welding fibre laser welding solution a robust and versatile choice for various industrial welding applications.

The laser welding solution from Valk Welding offers:

- A completely safe CE solution for your employees
- Optimal performance and welding quality through 100% integration
- With or without filler material
- Shorter ROI thanks to offline programming
- Complete peace of mind with Valk Welding service support
- A solution including welding jigs (if required)

Plastic welding

Valk Welding has designed a complete automation solution for plastic welding. The robot is equipped with an industrial plastic welding application that speeds up the welding process and enables greater precision.

For plastic welding with a robot, a carbon brushless extrusion welding machine specially designed for robot use is used. To create a good, strong weld, both the base material and the filler material must be at the right temperature.

The speed at which the weld is applied is important, as is the correct pressure with which the weld is pressed against the base material. This used to be a challenge, especially when the welding direction changed. With the Valk Welding tool holder, the welding robot can compensate for distance changes in two directions. These are both pneumatically controlled to ensure constant welding pressure. The hot air, the amount of material and the welding speed can be set independently, making it possible to weld corners without the risk of burning the base material or melting too much material.

02

The robot

Valk Welding provides clarity, certainty, and complete peace of mind. This allows our customers to focus on their own production without worrying about the technology behind it.

For a stable and reliable welding installation, complete coordination between the robot, welding process and software is essential. That is why Valk Welding has consciously chosen the unique robot technology from Panasonic, which, like us, designs and manufactures everything in-house. This combination ensures a seamless, plug-and-play solution in which all components are perfectly matched. One technology, one responsible party, one point of contact.

Panasonic TAWERS series

The Panasonic TAWERS welding robot series stands for "The Arc Welding Robot Series" and is the first and only robot system in the world that uses a single processor to control both the robot and the power source completely digitally. The 100 kHz inverter technology also offers unique possibilities with a wide range of welding processes. The Panasonic TAWERS™ series includes various robot models with the WG and WGH robot controllers. The welding robots of the Panasonic TAWERS™ series enable you to influence key factors of your business, such as quality, accuracy, flexibility, and cycle times.

We will work with you to select the right solution for your needs and requirements. Below is an overview of the options available.

Robot calibration

At Valk Welding, all incoming robots are calibrated to ensure optimal performance. Our unique procedure integrates all mechanical elements when determining the Tool Centre Point (TCP). This ensures that robots can work with true precision. The TCP is a crucial parameter for a welding robot, as it determines the location of the welding arc on the welding torch.

A correctly defined and calibrated TCP prevents poor weld quality, longer production times and higher costs.

TM series with internal, external or hybrid hose package

The TM series is available with the long-life, quick-change Valk Welding VWPR hose package via the robot arm (internal, with a focus on reducing cable interference) and outside the robot arm (external with a focus on wire feedability).

With the hybrid solution, only the welding wire cable runs outside the robot arm. The welding current cable, shielding gas, compressed air and water cooling pass through the robot arm. The hybrid hose package is the perfect solution for the fast Panasonic robots, thanks to its lower weight and greater flexibility for optimum accessibility of your parts. This results in a longer service life for the hose package and guarantees the best wire feed.

TL series

The TL series offers the same functionalities as the TM series, with the difference that the hose package is always routed externally along the robot arm. In addition, the TL series is more compact and completely symmetrical in design, which is particularly advantageous when mirroring programmes.

TM-series



Internal cable assembly



External cable assembly

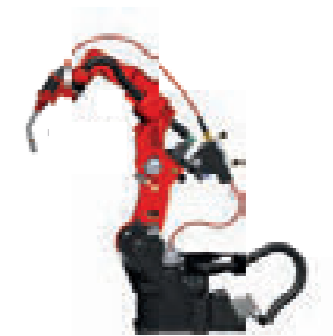

Hybrid cable assembly

TL-series



- Higher payloads
- Symmetrical design for optimal mirroring of robot programs
- External cable assemblies only

TS-series



- Floor, ceiling and wall mount High speed
- 48% smaller footprint
- Suitable for Super Active, TAWERS-TIG/TAWERS

LA-series



- World-leading in its class in terms of loading, accuracy, speed, and range
- High accuracy in (laser) welding and handling
- Synchronised with welding robot for jigless welding

	Max. payload	Max. reach	Max. speed	Repeatability	Robotweight
TM-1100	6 kg	1.163 mm	180m/min.	+/- 0,08 mm	+/- 156 kg
TM-1400	6 kg	1.437 mm	180m/min.	+/- 0,08 mm	+/- 170 kg
TM-1600	4 kg	1.639 mm	180m/min.	+/- 0,08 mm	+/- 180 kg
TM-1800	6 kg	1.809 mm	180m/min.	+/- 0,08 mm	+/- 215 kg
TM-2000	6 kg	2.011 mm	180m/min.	+/- 0,1 mm	+/- 217 kg
TL-1800	8 kg	1.801 mm	180m/min.	+/- 0,08 mm	+/- 215 kg
TL-2000	6 kg	1.999 mm	180m/min.	+/- 0,15 mm	+/- 216 kg
TS-800	8 kg	841 mm	180m/min.	+/- 0,05 mm	+/- 55 kg
TS-950	8 kg	971 mm	180m/min.	+/- 0,05 mm	+/- 56 kg
LA-1800	26 kg	1.801 mm	180m/min.	+/- 0,07 mm	+/- 320 kg
HH-020L	20 kg	3.281 mm	180m/min.	+/- 0,15 mm	+/- 535 kg
YS-080G3	80 kg	2.240 mm	180m/min.	+/- 0,15 mm	+/- 620 kg
HS-220G3	220 kg	2.666 mm	180m/min.	+/- 0,15 mm	+/- 955 kg

HH-020L



- Max. draagvermogen 20 kg
- Max. bereik 3.281 mm
- The HH-020L can perform the same arc welding tasks as the TM/TL robot

Handling robot YS-080G3



- Max. payload 80 kg
- Max. reach 2.240 mm
- Synchronised with welding robot for jigless welding

Handling robot HS-220G3



- Max. payload 220 kg
- Max. reach 2.666 mm
- Synchronised with welding robot for jigless welding

VWPR QE welding equipment

We strive not only for the perfect welding robot, but also for perfection in the complete welding equipment. This integrated approach enables us to achieve a demonstrably higher OEE (Overall Equipment Effectiveness) and a structurally low TCO (Total Cost of Ownership) for maximum output and minimum operational costs.

Valk Welding produces a unique robot torch for the welding robot systems, complete with pneumatic shock sensor, long-life hose package, accurate wire clamping mechanism and quick goose neck replacement.

VWPR QE safety holder

The VWPR QE safety holder plays a crucial role in this. On one side, the safety holder contains the Quick Exchange connector for the cable package, making it extremely easy to replace the cable package without changing the Tool Centre Point (TCP). On the other side, the quick-change system for the torches offers the advantage that welding torches can be changed quickly, also without changing the TCP.

Both sides of the disconnect ensure that robot programmes do not need to be checked or adjusted after replacing the welding torch or hose package. The disconnect is available for all hose package configurations: internal, external and hybrid.

Maximum welding performance with the Valk Welding VWPR Servo Pull

Thanks to the servo-controlled wire feeding at a short distance from the welding process, we take both the MIG and TIG welding processes with cold or hot wire to the highest level. We achieve this by eliminating the movement of the wire in the hose package. This latest development, combined with the TAWERS platform, in which the robot, power source and wire motor are controlled by a single CPU, takes your welding application to an unprecedented level.

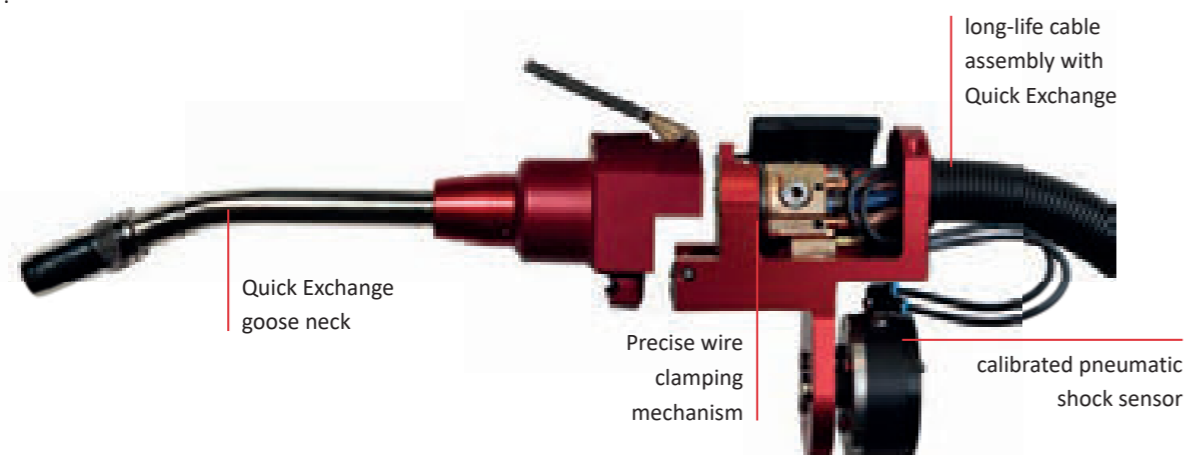

VWPR QE MIG II torch

A complete line of welding torches for various welding processes is now available as standard. The VWPR welding torches are characterised by their accurate calibration, which is carried out as standard and ensures that torches can be changed quickly without the need for reprogramming. The VWPR QE MIG II torch forms an important basis for this.

Features of the VWPR QE MIG II welding torch:

- Innovative design with fewer wearable parts, resulting in less maintenance
- Three contact tip positions possible: protruding beyond the gas nozzle, flush with the gas nozzle, or retracted
- Long contact tips and optimal cooling of the contact tip holder
- Separate supply of shielding gas to the contact tip, independent of the welding wire
- Tool Centre Point (TCP) remains the same
- Universal mounting of the gas nozzle
- Valk Welding standard liners
- "Quick Exchange" VWPR adapter, compatible with existing VWPR welding equipment

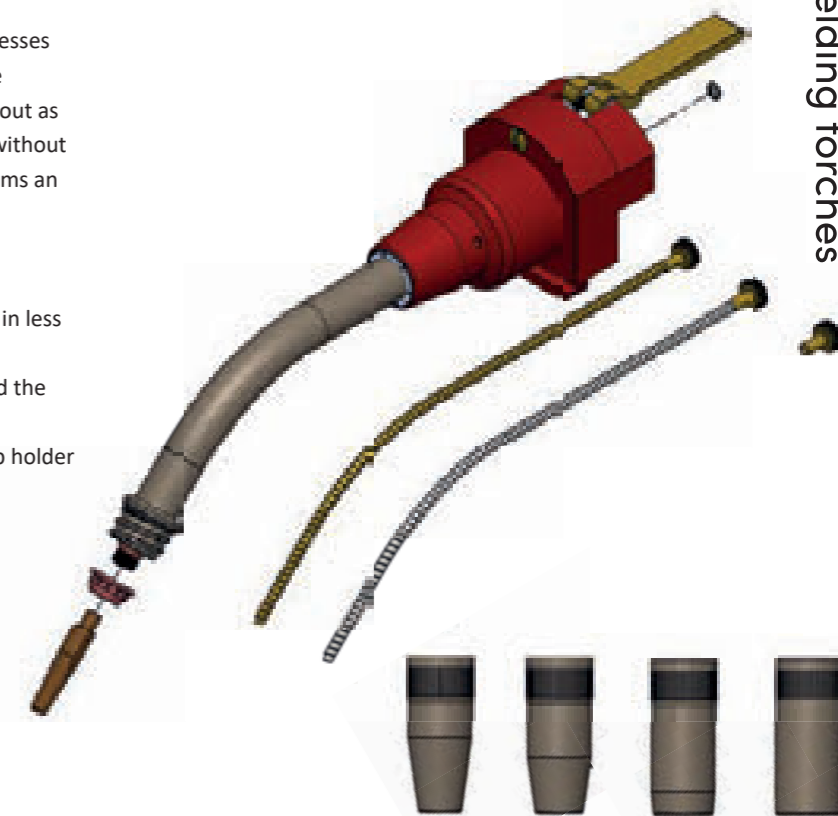

VWPR QE TIG II torch

The VWPR QR TIG II torch has been specially developed for thin-walled TIG welding with cold wire, resulting in high-quality, spatter-free welds. This torch offers stable wire feed, essential for perfect welding results in thin-walled materials.

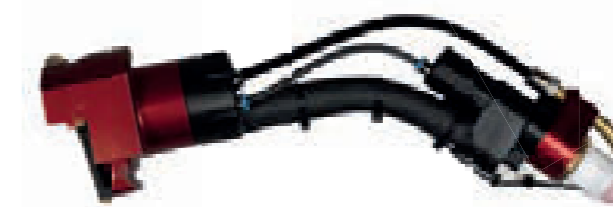

VWPR QE Internal

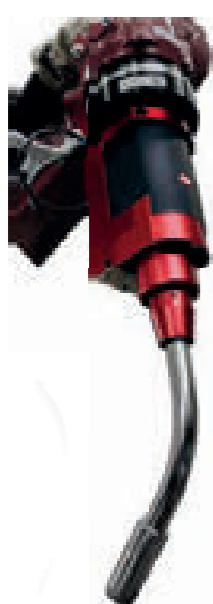

VWPR QE External

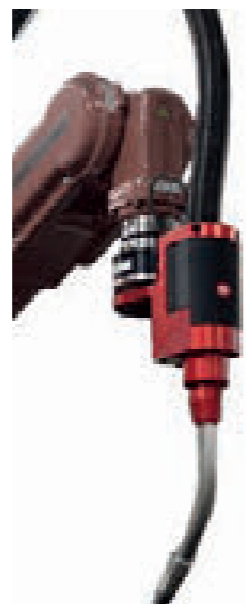

VWPR QE Servo Pull III

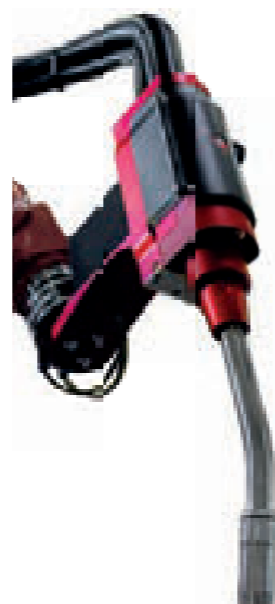

03

The configuration

Every production environment is different, just like every product that needs to be welded. For maximum results, a configuration that perfectly matches your situation is crucial.

Valk Welding develops complete welding setups that are not only tailored to the product but also the available space and the logistical processes within your facility.

FRAME-Table



FRAME-H



FRAME-C



FRAME-E



FRAME-C+FW
(Ferris Wheel)

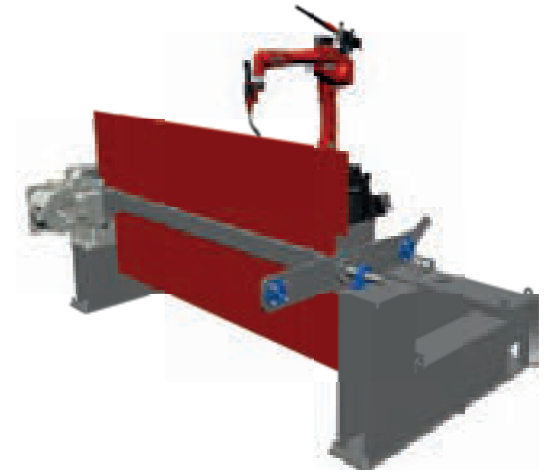

FRAME-IT
with indexing table



FRAME-IT+H with
turning table and robot
in the middle

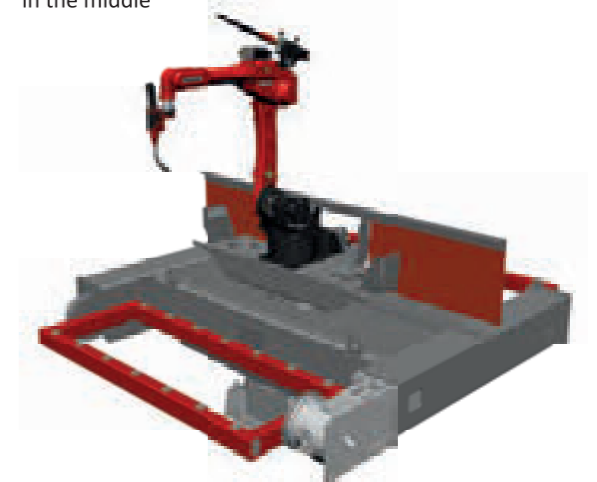

FRAME-IT+L
with L-positioners



FRAME-IT+H with
turning table and
robot at the back side



Valk Welding was the first to introduce mobile, fully machined rigid frames as the basis for its robot systems.

This innovation not only reduces setup time, resulting in lower costs and less disruption to your production, but also enables Valk Welding to pre-program the robot system. What is more, internal optimisation of your production is extremely easy, as you can move the entire system yourself.

Thanks to this development and our unique calibration system for robots, switching production between different systems or production installations is easy and you do not need to reprogram to start production immediately.



See our video

The TRACK-FRAME solutions are equipped with a longitudinal movement for the robot, which offers the perfect combination of optimal accessibility and the ability to work with larger workpieces, such as with a longitudinal movement, and the mobility of a frame concept. The TRACK-FRAMES can be machined up to 12 metres in a single clamping.

Optionally, both the counter bearing and the manipulator can be freely adjusted over the length of the installation, so that the size of the work area can be easily adapted to the dimensions of your product or welding jig.

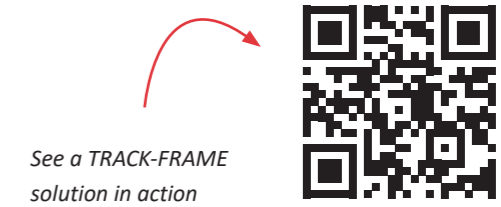

TRACK-FRAME-E

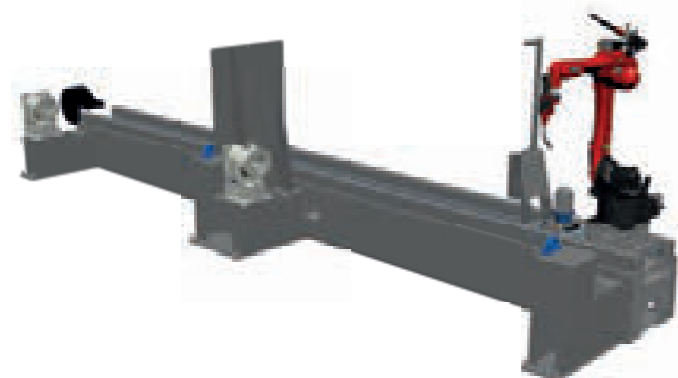

TRACK-FRAME-E SPECIAL

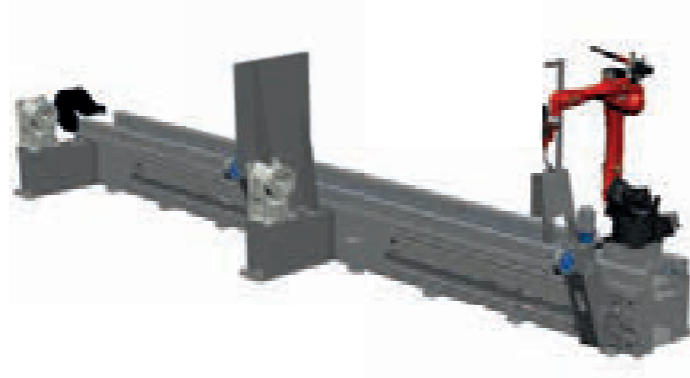

TRACK-FRAME-C

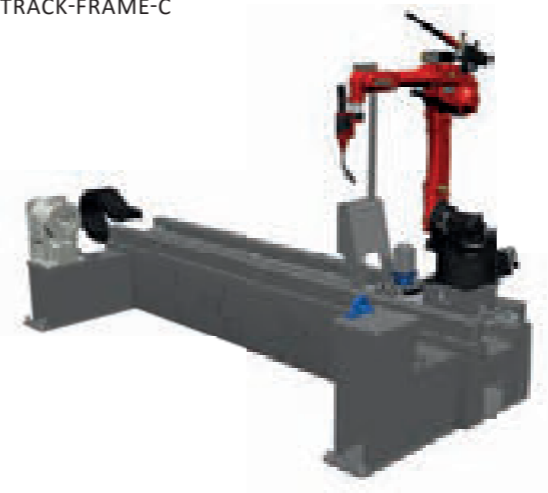

TRACK-FRAME-C+FW
(Ferris Wheel)

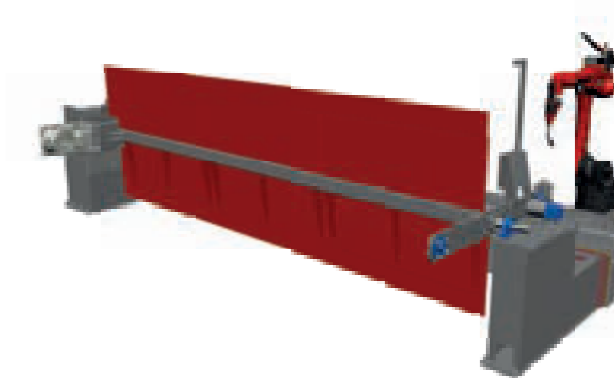

TRACK-FRAME-EE

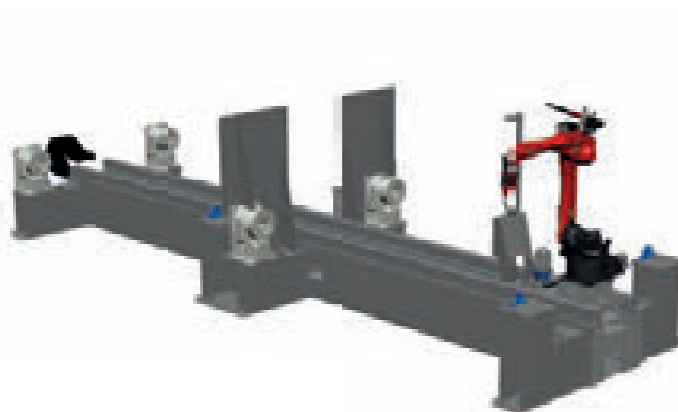

TRACK-FRAME-H

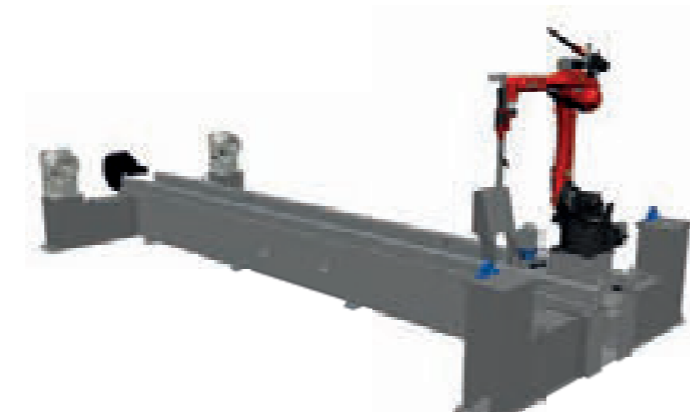

TRACK-FRAME-C-MCB
(Movable Counter Bearing)



TRACK-FRAME-Z-MCB
(Movable Counter Bearing)

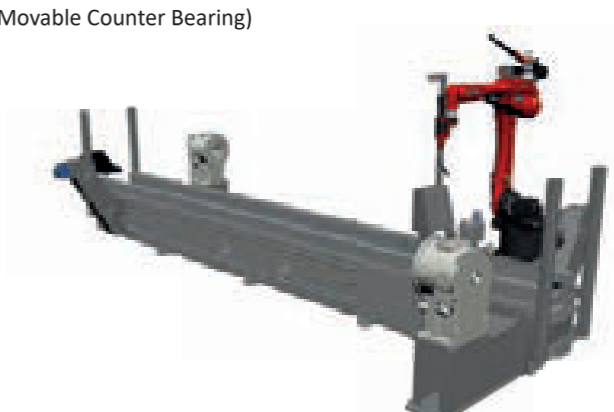

Single axis track

Track FS series

TRACK-Y-RL-FSM



Track FH series

TRACK-Y-RL-FHM



Track PH series

TRACK-Y-RL-PHM



To enable 100% offline programming, our longitudinal displacement tracks meet the highest quality requirements in terms of accuracy and long service life, so that the virtual programming world corresponds exactly to the real-life system. We have already delivered more than 40,000 metres of shifter functionality. In short, our standard concepts have already proven themselves. Nevertheless, we continue to work on higher quality and additional options to meet the ever-changing demands of the market.

- Our systems are welded with a Valk Welding robot
- Fully machined for a precise result
- Optimised grounding

Double axes track

Track FS series

TRACK-YX-RL-FSM



Track FH series

TRACK-YX-RL-FHM



TRACK-YZ-RL-FHM-BACK



TRACK-YZ-RL-FHM-FRONT

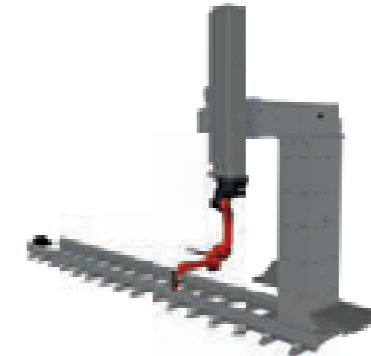

TRACK YR-RL-FHM

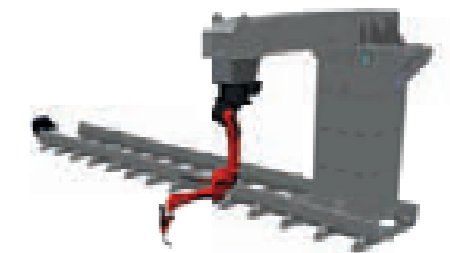

Triple axes track

Track FS series

TRACK-YZX-RL-FSM



Track FH series

TRACK-YZX-RL-FHM-BACK



TRACK-YRZ-RL-FHM



TRACK-YRX-RL-FHM

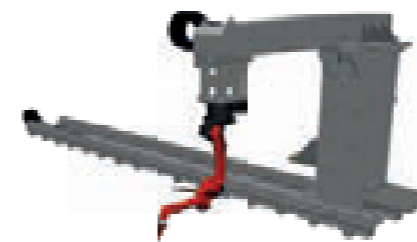

TRACK-YXZ-RL-FHM

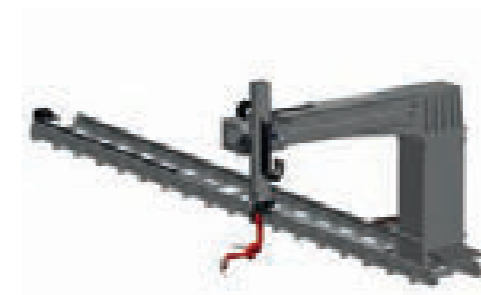

Track PH series

TRACK-YXZ-RL-PHM







Standard manipulator frames

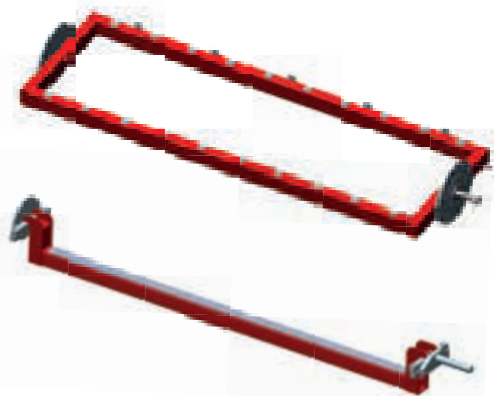

Smart positioning for higher quality, time savings and safety

The optimal positioning of workpieces is essential for an efficient and high-quality welding process. By using manipulators, manipulator frames and jigs, we ensure that every product is always in the best welding position, automatically and safely.

Manipulators

Available as standard with a load capacity of 250 kg to 20,000 kg. For applications above 20 tonnes, a manipulator is available on request.

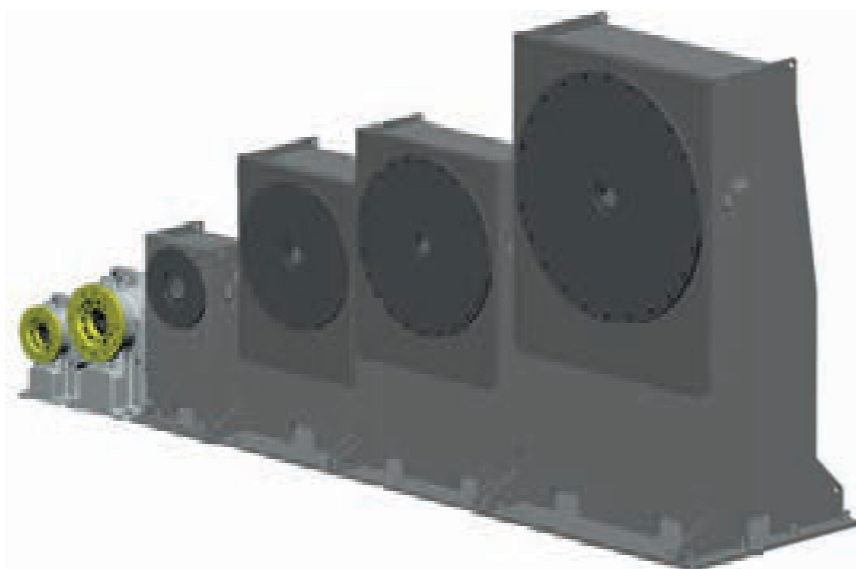

TT-I tube-tube manipulator

Valk Welding's patented TT-I tube manipulator for butt welding of 'endless' tubes.

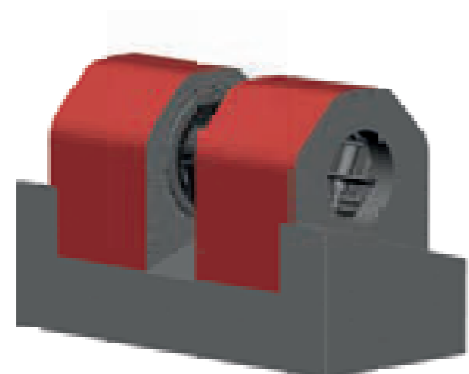

Pacman manipulator



Double axes dropcenter



Double axes L-shape

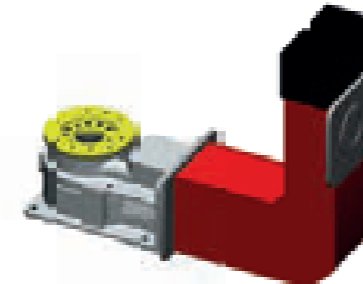

Triple axes Ferris Wheel

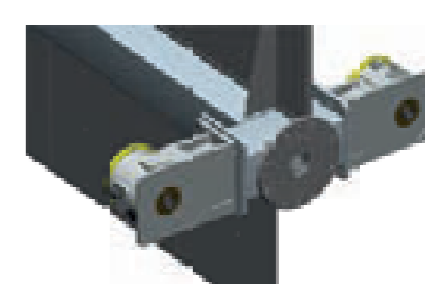

Welding Jig construction

A welding jig is an essential tool in the welding process. Its main purpose is to present the workpiece to the robot in the correct position so that the welding process is accurate and consistent. The jig also helps to keep the workpiece in the correct position during the welding process and prevents unwanted movements or shifts.

In addition to positioning the workpiece, the welding jig also plays a crucial role in the correct assembly of the workpiece. By holding the various parts of the workpiece in place, the jig ensures that they are assembled in the correct configuration and that the final product is within the dimensional tolerances.

The welding jig also helps to check that all parts are present and ensures that no parts are missing or incorrectly positioned. This is important for maintaining the quality and integrity of the product. Valk Welding develops these jigs to meet the specific requirements of each project.



Welding fume extraction

Depending on the configuration of the installation, Valk Welding offers various solutions for extracting welding fumes. These include both fixed elements for closed cabins and movable elements that move along with the robot on tracks.

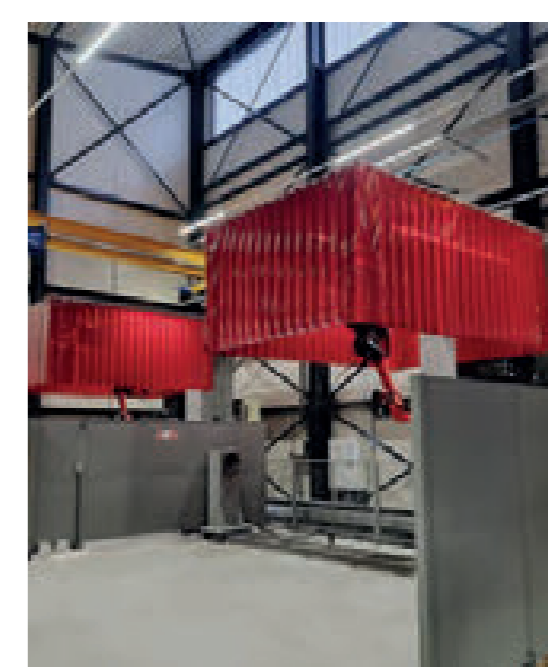

Safety as an essential requirement

A safe working environment is an important prerequisite for an attractive production environment. Not only to comply with applicable regulations, but also to create a working environment where people feel comfortable and protected.

Valk Welding helps companies to structurally improve work safety with solutions that make the working environment clearer, more ergonomic, and safer. This makes the workplace more attractive to employees, improves staff availability, and allows you to continue production with peace of mind.

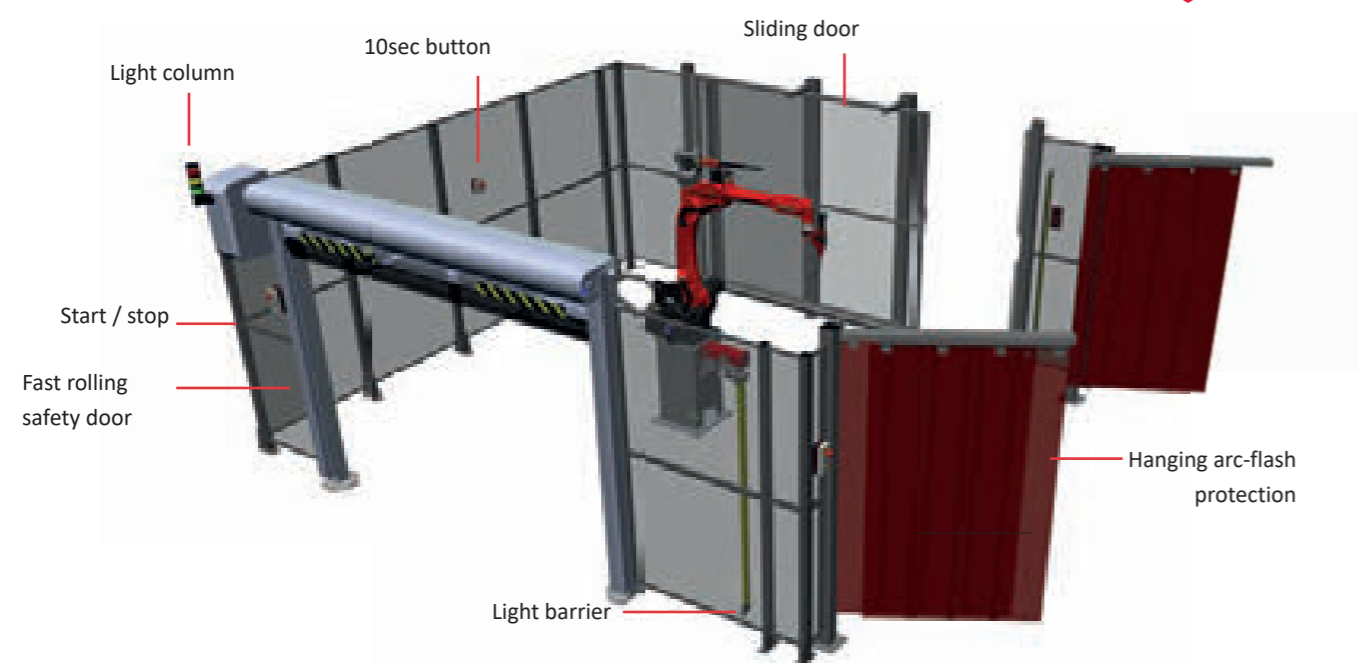

VWPR solution with built-in welding fume extraction

To optimally protect robot operators, Valk Welding has developed a VWPR torch with built-in welding fume extraction. In collaboration with the extremely accurate extraction unit, we have created a system that keeps operators safe, prevents direct contact with contaminants, and can be used flexibly on your robot system:



- The most powerful and efficient device on the market
- Specially designed to filter even the smallest, most harmful particles
- Includes a bag-in/bag-out system for safe maintenance of the unit
- Compatible with the VWPR MIG II FE torch
- Uses an automatic filter cleaning system using compressed air
- The VWPR ATMOFLOW extraction unit communicates directly with the robot during the welding process
- Based on the standard VWPR MIG II torch, you retain the same spare parts and reduce the total cost of ownership

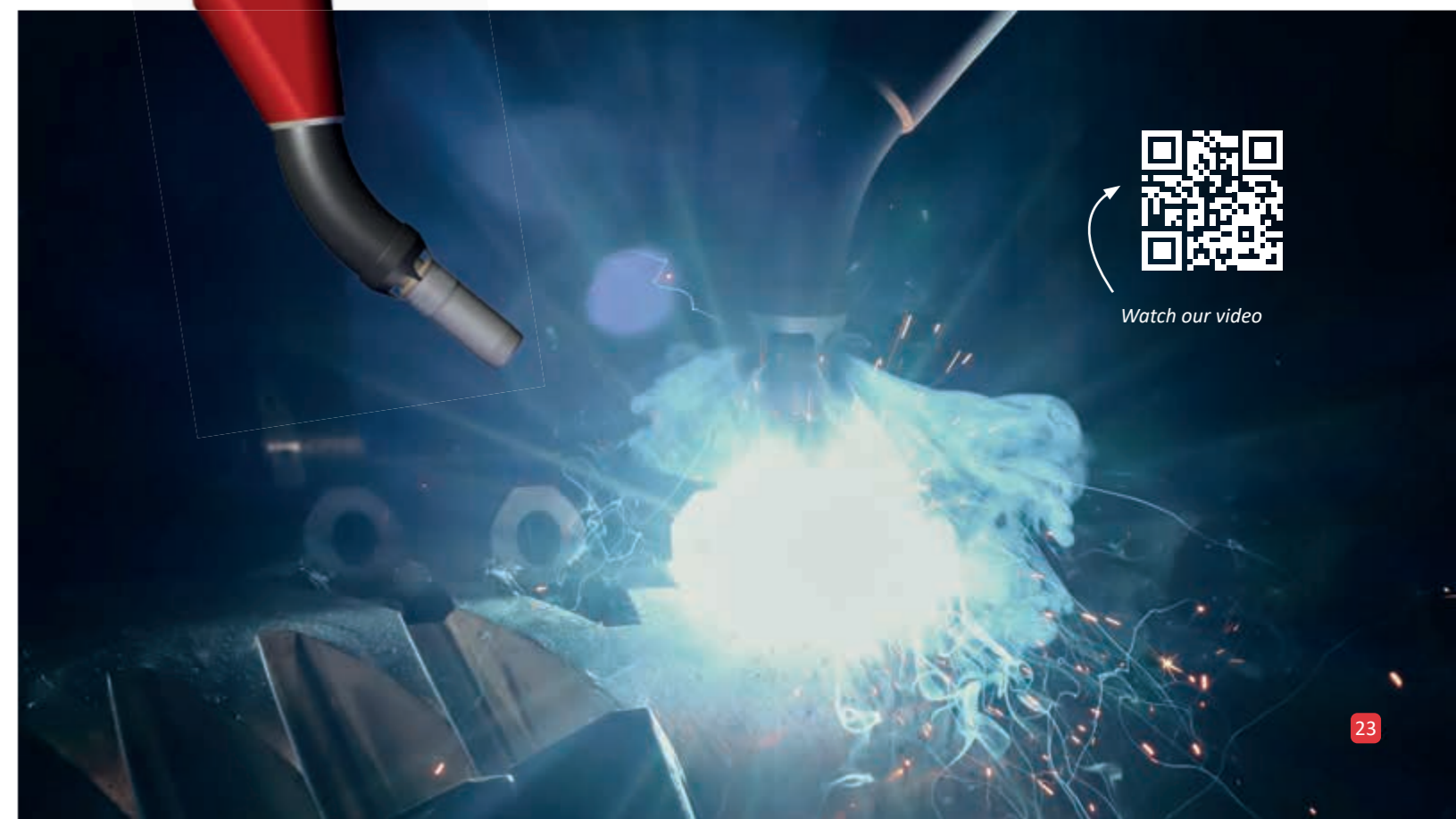

Thanks to advanced automation technology, this cell can operate without human intervention.



See more logistics solutions

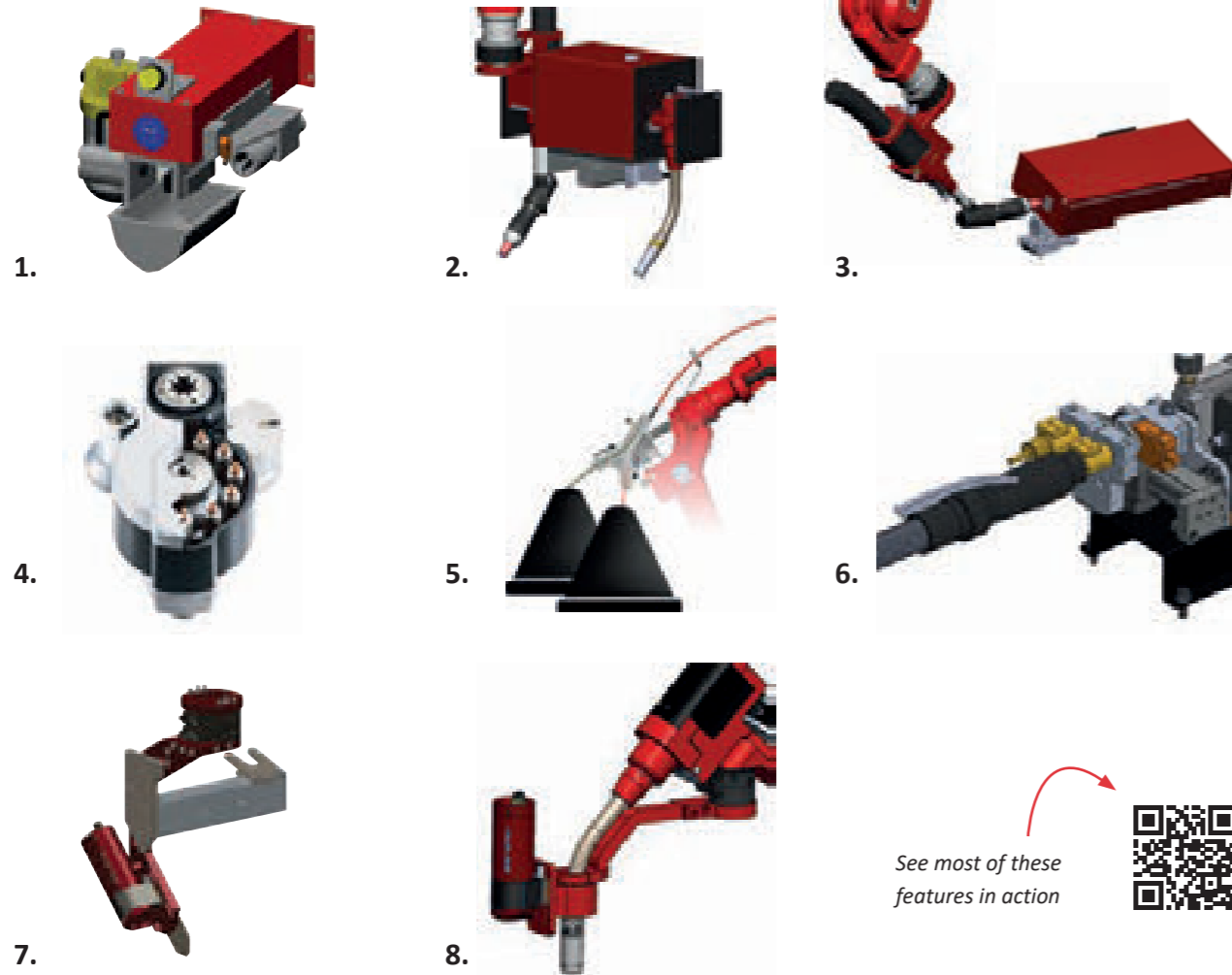

03 - Automation accessories

See most of these features in action



As a technology partner, we continue to innovate and can increase the return on your investment with both standard extensions and accessories as well as unique solutions developed by Valk Welding.

1. Mechanical cleaner

Mechanical torch cleaner with milling cutter, spray nozzle and external gas head cleaner.

2. Automatic torch exchange system (TES)

For automatic changing of torches, such as from MIG to TIG or from standard to special torches.

3. Automatic tungsten change system (TEES)

For automatic changing of the tungsten between production runs.

4. Tip Exchange System

Tip Exchange System for exchanging contact tips. This consists of a system for removing and attaching the gas cap, a mechanical exchange magazine for contact tips, a monitoring sensor, and a rotating cleaning unit for cleaning contact tips.

5. Wire Exchange System (WES)

The wire exchange system allows you to automatically switch between two different welding wires, such as steel and stainless steel. You can also automatically switch between welding wire drums when

one of the two is empty. What is more, you can do all this with the same hose package and welding torch.

6. Cable Assembly Shifter (CAS)

When automatically switching between MIG and TIG with HF (high frequency) start and cold wire, it is important to keep the cold wire isolated from the MIG cable assembly due to the high frequency. The Cable Assembly Shifter makes it possible to use a single welding wire for both MIG and TIG HF by sliding the correct welding wire guide for the wire feed. In addition, the Cable Assembly Shifter makes it easy to switch between different types of materials, such as steel and stainless steel, and between solid and cored welding wire.

7. ARC-EYE exchange system

This system improves the accessibility of the welding torch where needed, as the ARC-EYE can be easily removed in situations where its use is restricted due to limited accessibility. All control functions for the ARC-EYE are fully integrated into the exchange system, allowing for quick and efficient changeovers without compromising functionality.

8. Rotating ARC-EYE

The Rotating Arc-Eye is a solution that offers maximum flexibility in determining the ideal welding position with the ARC-EYE laser camera. Because the camera can rotate around the welding torch, there is complete freedom of movement for accurate positioning of the camera and the torch in relation to the weld seam.

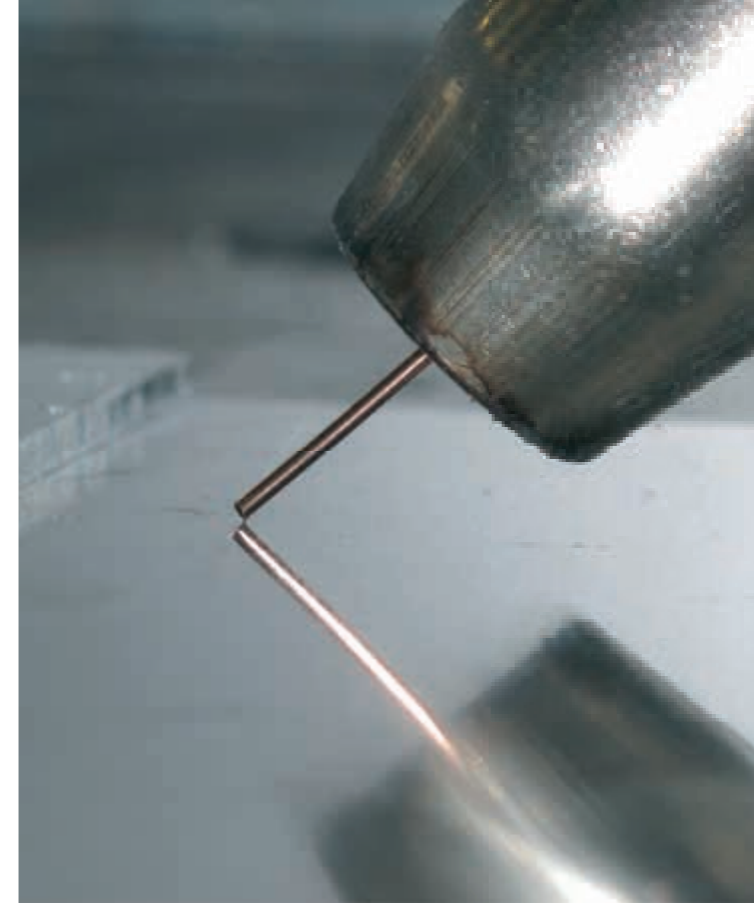

Sensors on an arc welding robot are important for a variety of reasons. They can detect deviations in the preparation of individual parts, deformation due to heat input during welding and poor positioning due to incorrect use of the welding jig. These sensors can help the robot to automatically adjust the welding parameters to changes in the geometry of the weld joint, thereby improving the quality of the weld.

Sensors are required if:

- The tolerances of the parts are incorrect
- The positioning of the parts is incorrect
- Deformation of the parts occurs during the welding process
- Different versions of a product can be placed in a single jig

03 - Searching for the weld seam

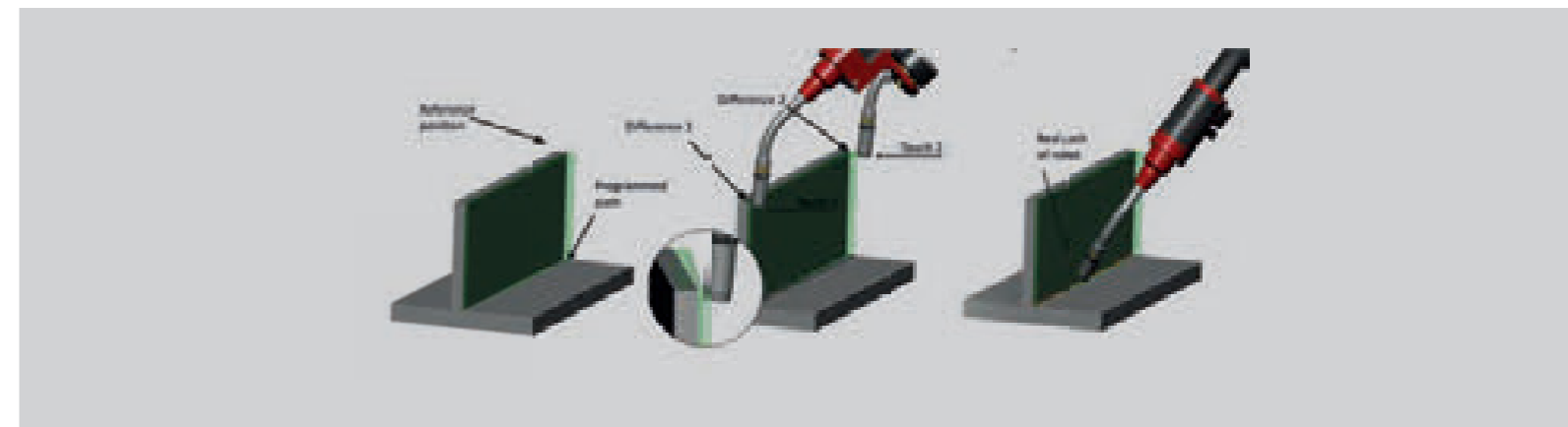

Quick Touch Sensing, certainty with every weld

With Quick Touch Sensing, the robot performs a smart measurement using the welding wire as a sensor before welding. This determines the exact location of the weld, regardless of minor variations in the workpiece or clamping.

This automated wire measurement is fast, accurate and fully integrated into the welding cycle. The result?

The robot automatically adjusts the program, ensuring consistent weld quality even with small tolerances or variations in the position. Quick Touch Sensing prevents surprises during welding and thus forms the basis for reliable, reproducible production.



More information about Quick Touch Sensing

Welding that was previously impossible!



Watch our video



Where classic weld seam tracking stops, ARC-EYE goes further

In addition to searching with the gas nozzle and searching via the welding wire (Quick Touch), Valk Welding has developed the ARC-EYE weld seam tracking system, ARC-EYE CSS laser sensor system.

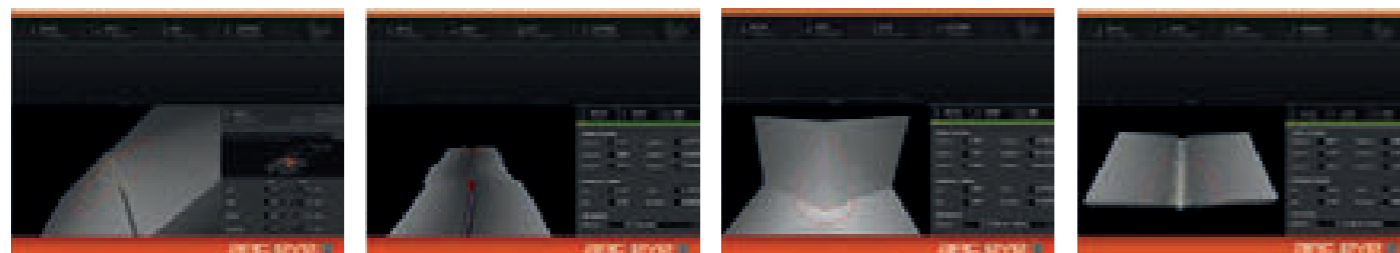

ARC-EYE CSS

Many products are difficult to automate due to variations that occur during welding, such as warping or unpredictable tolerances. The ARC-EYE CSS laser sensor breaks through this barrier: this system makes it possible to weld those difficult products precisely, reliably and automatically – opening the door to a whole new group of applications.

The ARC-EYE CSS (Circular Scanning Sensor) guides the robot in real time during welding and continuously tracks the exact weld seam. Where traditional weld seam detection stops, ARC-EYE CSS continues. Think of difficult situations such as:

- Aluminium or thin-walled material that deforms quickly
- Narrow or variable pre-openings
- Blunt seams, small V-seams or overlap seams

Thanks to this real-time detection, it is no longer necessary to take

measurements in advance or manually correct tolerances in the welding program. The robot adapts automatically – directly during welding – which leads to:

- Higher weld quality
- Less rejects and rework
- Reliable automation, even with product variation
- The ability to automate new product variants that were previously unsuitable for robot welding

Safety is also guaranteed: the ARC-EYE CSS uses a low-power laser (< 5 mW), which makes the system a class 3R solution. This means that no additional shielding is required, and the cell remains compact, clear, and safe.

ARC-EYE CSS makes robot welding accessible to a much wider range of products – and therefore to more companies than ever before.

ARC-EYE Adaptive

Welding and weaving parameters can also be adjusted automatically. The ARC-EYE Adaptive Welding plug-in adjusts parameters such as welding speed, welding current, welding voltage, weaving amplitude and more in real time. This makes even the most complex welds possible for robot welding, even in more difficult materials such as stainless steel or on workpieces with larger and irregular tolerances. Irregular pre-opening, deviating weld seam preparation or deformation caused by the welding process can cause the geometry of the weld seam (seam shape) to deviate. Even a small geometric deviation can quickly lead to a volume deviation of 40% to 80%. This not only requires much more welding material, but also a different welding method. With the Adaptive plug-in, the ARC-EYE CSS laser sensor recognises the seam shape and automatically adjusts the welding program accordingly.

The Adaptive Welding function can be used simultaneously with ARC-EYE CSS weld seam tracking, ensuring optimal position and orientation of the welding torch.

ARC-EYE Multi-pass

When the volume per section varies during multi-layer welding, it is necessary to distribute the welds differently per section. This may require different welding strategies for each section. Valk Welding engineers are currently working on Adaptive Seam Mapping, which automatically calculates and generates each weld, layer by layer. During or after the root seam is welded, the ARC-EYE CSS scans the seam shape and uses this data to calculate the most suitable weld distribution. This takes into account the varying weld volume and the minimum/maximum heat input allowed per weld.



04

Software

Valk Welding software plays an increasingly important role in controlling and optimising the production process. By automating work preparation and execution, errors are reduced and valuable time is saved. Real-time insight into performance and production data makes it possible to make targeted adjustments to processes, monitor quality and implement continuous improvements. For companies with multiple installations, this creates a scalable, streamlined, and transparent working environment in which standardisation, control and efficiency are key.

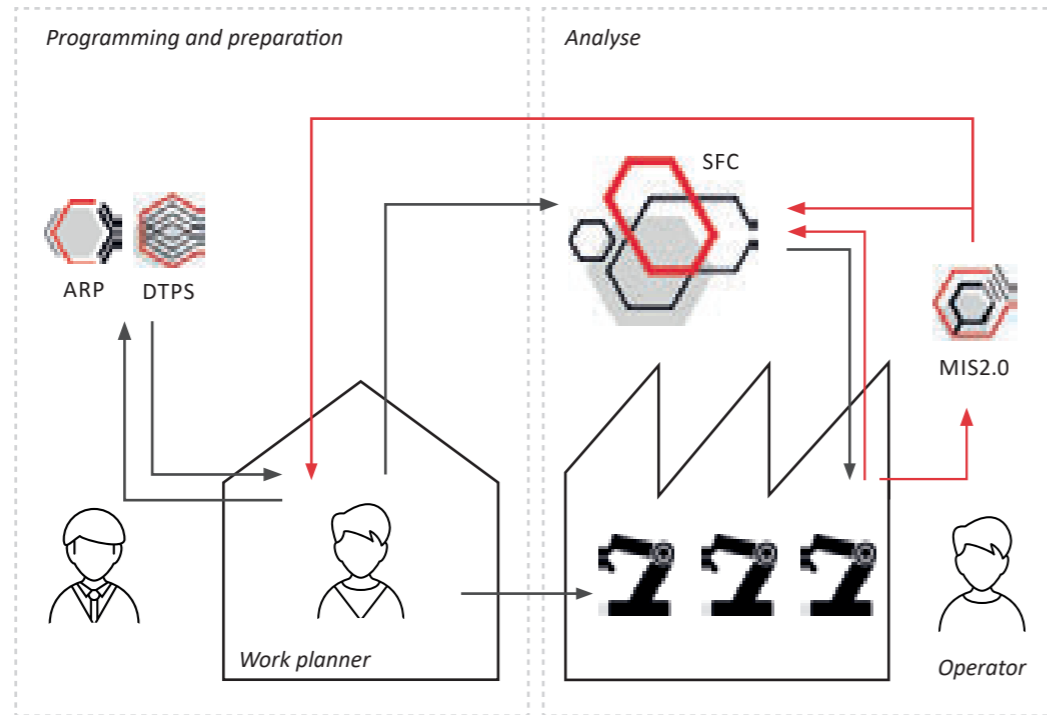

Programming the robot

ARP - Automatic Robot Programming
Automatic Robot Programming (ARP) is a collection of solutions that simplify the offline programming process and speed it up by up to ten times. This not only drastically increases the efficiency of this process but also makes welding automation attractive for single-piece production. ARP software automatically generates and simulates welding programmes from 3D CAD files or other information sources, which means you do not need extensive programming knowledge. Many steps can also be automated within product families, so that a separate program does not have to be created for each product variant.

DTPS - Desktop Programming and Simulation Software

DTPS (Desktop Programming and Simulation Software) is a fully-fledged 3D CAD/CAM system for programming and simulating the welding process on Panasonic arc welding robots. The offline programming software replaces programming with a teach pendant (an advanced remote control) directly on the robot. This means that

production does not have to be interrupted for programming and maximum uptime of welding robot installations can be achieved. With DTPS, programmers can program the most complex workpieces from behind their screens without having to stop the welding robot. After importing a workpiece from a CAD system, the work planner specifies the welding positions, including the desired welding parameters. Because the software offers powerful 3D simulation with collision detection, the programmes can be checked down to the finest detail before being sent to the welding robot's control system. In addition, the templates and fixtures can be designed and tested. DTPS forms the basis for various software programmes.

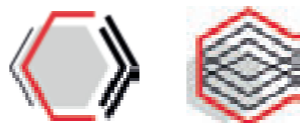

Analysing the production process

SFC - Shop Floor Control

Shop Floor Control, or SFC, is an application for automating, structuring, and managing the office and workshop environment of the robotic welding process. SFC automates everything from planning to operator instructions. The platform utilises the ability of Panasonic robots to request and send live data. SFC is a valuable addition, especially for companies with multiple workstations or welding robot installations.

SFC ensures clear and transparent communication within the company. Production can be fed by means of barcodes or pre-planned products to be produced. The operator then uses the barcode or planned production batch to automatically provide the robot installation with the correct and most recent set of robot programmes. Any improvements can be communicated to the programmer using a chat function.

These chats are automatically linked to the relevant production. This means that the programmer does not always have to be on site. Everything is recorded transparently, time-bound and in the correct context.

MIS - Management Information System

The Management Information System (MIS) is a software program developed by Valk Welding that gives companies real-time insight into what is happening with the robot installations in production. From a PC, mobile phone or tablet, in production or on the road. Companies with multiple welding robots in use want more insight and control at management level over performance, process flow, maintenance, and welding data. This data is needed to be able to adjust the process in a suitable time and increase efficiency and is necessary to record the welding quality per product.





Customer ERP System

Fleet Manager

AGVs

SFC

DTPS

ARP

Valk Welding software controls unmanned production at Meijer Metal 24 hours a day

When the employees at Meijer Metal in Sint Jacobiparochie, Friesland, start their working day in the morning, the welding robots have been producing all night long. Four welding robot cells are loaded and unloaded 24/7 by AGVs without human intervention. The company is thus building the factory of the future, in which a large part of the handling is automated.

Watch the video to see this solution in practice.

05 Welding wire

Valk Welding's Welding Wire Service Centre offers reliable, predictable, and flexible deliveries of high-quality welding wire directly from stock and without the intervention of third parties. You can count on the right wire, at the right time and in the right place, which contributes to a stable and high-quality welding process. Thanks to our consistent wire quality and an expert, committed team that perfectly matches the welding wire to Valk Welding technology, you can be confident in your welding quality.

Welding Wire Service Centre

The Welding Wire Service Centre offers predictable, flexible deliveries of welding consumables without the involvement of third parties. We take care of the logistics and quality, so you receive small to large quantities of welding wire directly from stock.

As a family business with more than 45 years of experience, we offer a unique combination of knowledge about welding wire and industrial welding robots. Our Welding Wire Service Centre is an important part of Valk Welding, where we supply high-quality welding wires.

The Welding Wire Service Centre has:

- Large stocks
- Direct and flexible delivery
- Scheduled logistics processing
- Consistent quality welding wire
- Skilled and helpful team at your service

Regional and personal service

For questions and logistical and technical support regarding wire selection, in addition to our strategically located distribution centres in the Netherlands, the Czech Republic and Denmark, you can also contact one of our regional customer service centres in France, Germany and Ireland. Here you can consult in your own language without the need for intermediaries. Our Irish centre also has additional stock in case of unforeseen circumstances.



Wire Wizard – wire feeding from A to Z

Wire feeding does not have to be a source of malfunctions or delays. With Wire Wizard, it becomes a reliable link in a stable and efficient production process. Each solution is specifically designed to prevent or eliminate problems such as downtime, inconsistent weld quality and unnecessary maintenance costs.

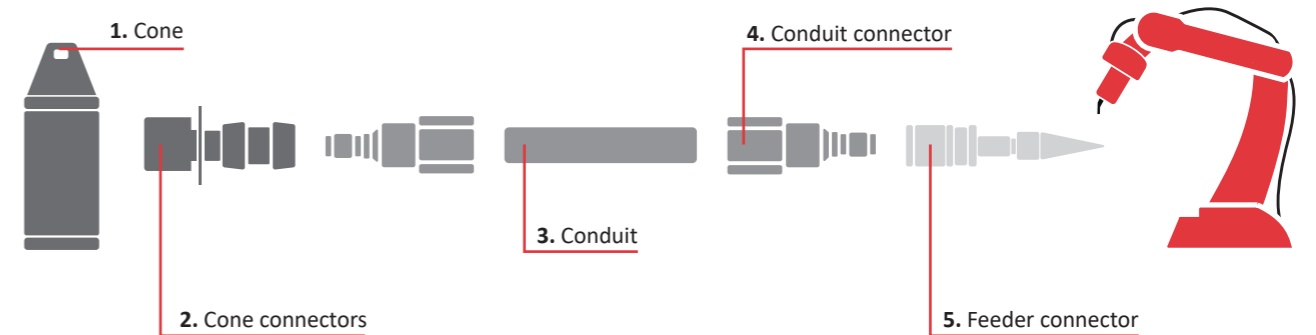

About Wire Wizard

Wire Wizard has been a global leader in wire feeding systems since 1985. The brand has been active in Europe since 1999, where we continuously improve our solutions by working closely with welding specialists. This practical approach ensures more than just technical reliability: it ensures higher productivity of welding robots, longer equipment life, fewer interruptions, and lower maintenance costs.

One system for the entire welding industry

Wire Wizard solutions are fully compatible with all types of welding robots, wire feed motors and virtually any drum or spool size. A suitable cone and connector are available for every type of application. In combination with our flexible liners, all components can be easily and quickly connected to form a single powerful system.

For applications with larger wire diameters, such as submerged arc welding (SAW), Wire Wizard also offers a special product line suitable for wire up to 5 mm.

Smart combination in five steps

Wire feeding does not have to be complex. With the Wire Wizard system, you can put together a complete solution in just five clear steps, tailored to your installation and working environment. The combination of universal connectors, a clear selection of components and quick couplings ensures a user-friendly and low-maintenance system that continues to perform reliably.



Please visit our website for more information and the complete product range.

The strong connection



Valk Welding NL
Staalindustrieweg 15
2952 AT Alblasterdam
Tel. +31 78 69 170 11

Valk Welding BE
Tel. +32 3 685 14 77

Valk Welding FR
Tél. +33 3 44 09 08 52

Valk Welding DK
Tel. +45 64 42 12 01

Valk Welding CZ
Tel. +420 556 73 0954

Valk Welding DE
Tel. +49 152 29 109 708

Valk Welding PL
Tel. +48 696 100 686

Valk Welding SE
Tel. +46 510 48 88 80

Valk Welding IE
Tel. +44 28 3886 8139

Valk Welding FI
Tel. +358 3 4109 0466

info@valkwelding.com
www.valkwelding.com

