

METAL FINISHING MACHINES

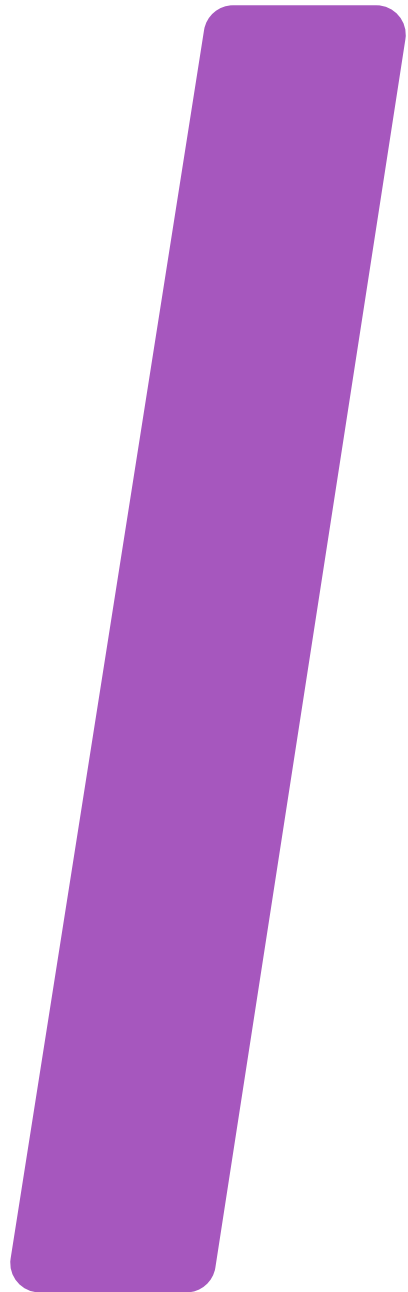

NS
MAQUINAS

INNOVATION AND EVOLUTION



WHERE?

NEXUS

CUSTOMERS
TESTS AND DEMONSTRATION

PRODUCTION
ASSEMBLING AND R&D

PEOPLE
OFFICES

SUPPLIERS
COMPONENTS

EVOLUTION
AUTOMATED MACHINES

DEVELOPMENT
CONTINUOUS IMPROVEMENT

INNOVATION
NEW MODELS

SOLUTIONS
INTEGRATIONS

ALL-ROUND PARTNER FOR METAL FINISHING

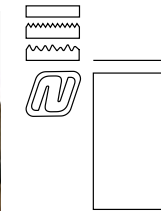

SHEET METAL DEBURRING

cut parts and sheet metal

EVO advanced deburring features

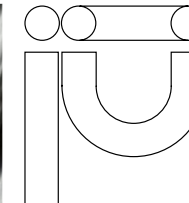

ROUND TUBE FINISHING

straight and bent tube

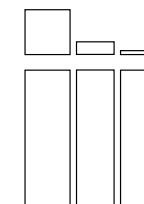

FLAT SURFACES FINISHING

flat bar and rectangular tube

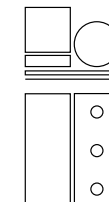

FINISHING, MIRROR POLISHING AND DRILLING

multipurpose

long belt finishing machines

mirror polishing machines

drilling machines

belt grinding universal machines

REFINING SURFACES, MASTERING EVERY EDGE

We take pride in our range of machines and in providing crafted solutions to address the industry needs.

The Nexus building is a manifest of our dedication to fostering an environment of continuous evolution, development, and innovation, all centered around providing optimal solutions for the market.

With our customer-centric approach, we aim to facilitate seamless progress and success within the metal fabrication industry.

SOLID ENGINEERING

We are renowned for the robust engineering as well as delivering reliable and adaptable machines for the most demanding markets.

Designed for durability, easy maintenance and optimal performance, our machines provide ample operational capacity, accommodating diverse production needs.

“We put all of our machines through a grueling pace throughout a day (...). A lot of them are running 24/7 and we haven’t had any problem with them at all. Plus, we’re actually running them outside of the envelope the machine was designed for.”

Kevin Harding, Camdel Metals Corporation, USA, about the ML100 3Z

CONSTANT INNOVATION

We continually pioneer the design and production of machines for the metal finishing and deburring markets. Our dedicated engineering team ensures that we drive this evolution in-house.

This dedication to advancing technology is evident in the development of automated loading systems, as well as an approach to refine each machine generation, emphasizing efficiency and an ergonomic design.

MORE THAN 20 YEARS EXPERIENCE

With over 20 years of industry experience, NS Máquinas has established a global presence, with approximately 5000 machines operating across 60 countries.

We offer the widest range of metal finishing machines, catering to various production scales, from small workshops to continuous operation lines.

Backed by a robust technical and sales network spanning five continents, we provide comprehensive support from initial setup to ongoing technical assistance, ensuring efficient and timely service delivery.

SHEET METAL DEBURRING



deburring
or surface
finishing



slag
removal



edge
rounding



single
sided



double
sided



> **EDGE ROUNDING** unit
both for small and large parts
with abrasive cross belts

> **DEBURRING** heavy or
light burrs, dross or slag after
laser, plasma, shearing or punching
with wide belt contact roller (Z)
or with large deburring drum (D)

> **SINGLE AND DOUBLE SIDED
EDGE ROUNDING OPERATION**

> **FINAL SURFACE FINISHING**
with oscillating brush (K) or with
non-woven wide belt (Z)

> **DIFFERENT WORKING
WIDTHS** from 1100mm up
to 1600mm

DM

DEBURRING SOLUTIONS

During sheet metal cutting processes performed by laser, punching, plasma or oxy-fuel cutting the edges of the cut parts often gain sharpness, a burr or even a heavy slag.

NS Máquinas has dedicated solutions for deburring and edge rounding either thin metal or thick metal sheets, in one side or on both sides of the workpiece.

Smoothing these inner and outer contours is often required both for safety and technical reasons.

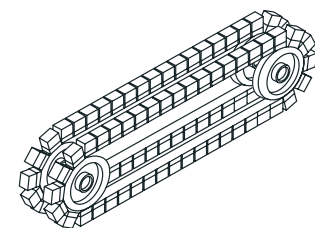

edge rounding **C**



__ a crossbelt system with counter-rotating abrasive blocks is used to make edge rounding on laser, punch, shear or waterjet cut parts

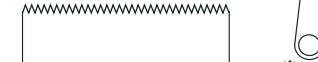
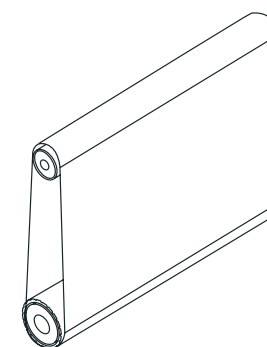

deburring **Z**

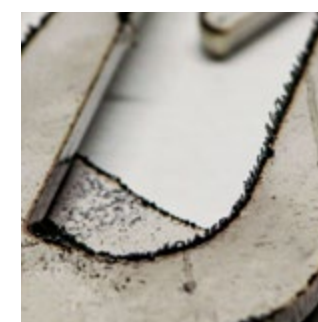

__ a wide belt abrasive unit is employed to remove burrs from the laser and plasma cutting process

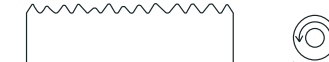
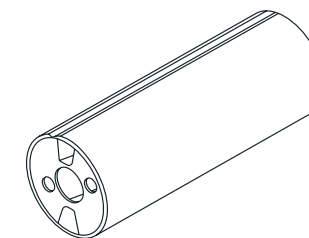

dross removal **D**



__ a larger diameter grinding contact drum is utilized to remove dross on thick steel plates from plasma and oxyfuel cutting

DM1100 C / EDGE ROUNDING
___ JOB-SHOP VERSION



___ two abrasive cross belts operating in opposite directions, completing edge rounding in every corner of the part



___ strong edge rounding on parts down to 50x50mm



___ parts return system improves productivity on small parts or double sided operation

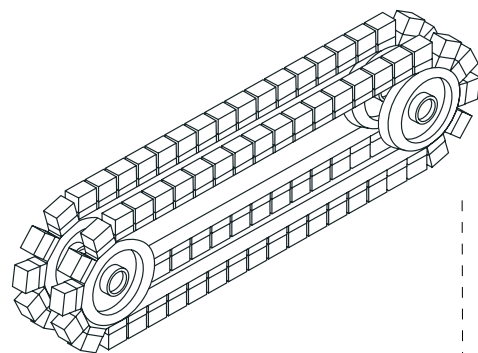

DM1100 C



DM1600 C

scan the QR CODE to watch the machine demonstration video



1100mm working capacity

___ DM1100 C

or

1600mm working capacity

___ DM1600 C

DM1100 Z / DEBURRING AND SURFACE FINISHING

___ JOB-SHOP VERSION

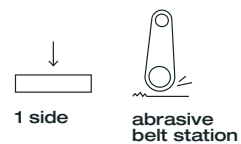

___ the abrasive belt station has a large diameter contact roller with Ø180mm diameter and 55SH, allowing for both deburring and finishing operations



___ intuitive adjustments with a digital ammeter to check contact roller pressure

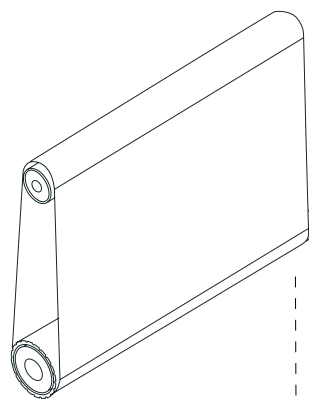

___ thickness is adjusted on an easy-to-use wheel with a 1/10mm precision display



___ the machine was developed to deburr metal parts cut by laser, punching or shearing

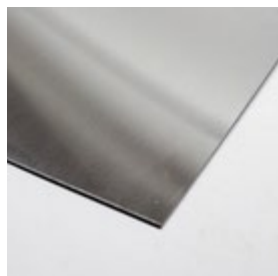
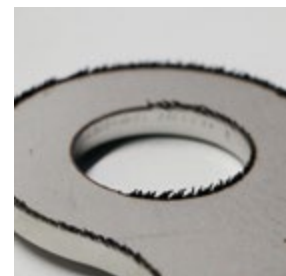

DM1100 Z

scan the QR CODE to watch the machine demonstration video

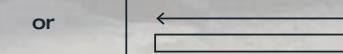
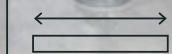

1100mm working capacity

1600mm working capacity

___ DM1100 Z

___ DM1600 Z

DM1100 ZC / DEBURRING AND EDGE ROUNDING
__ JOB-SHOP VERSION

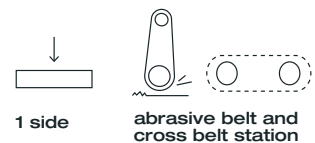

__ deburring and edge rounding with an abrasive contact roller and cross belt system

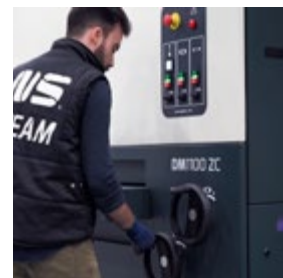

__ simple adjustments integrated on the machine for a quicker, more intuitive and reliable thickness and pressure

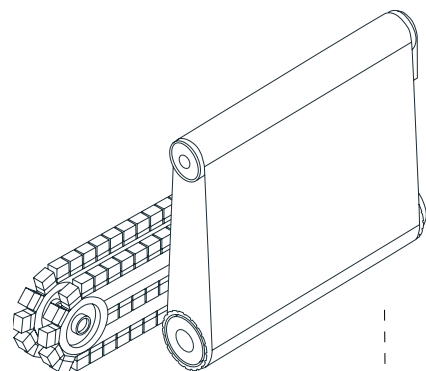

DM1100 ZC

DM1100 ZC
__ JOB-SHOP VERSION

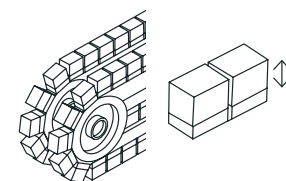
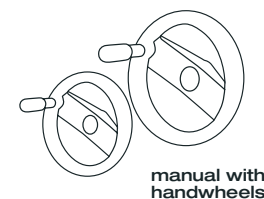
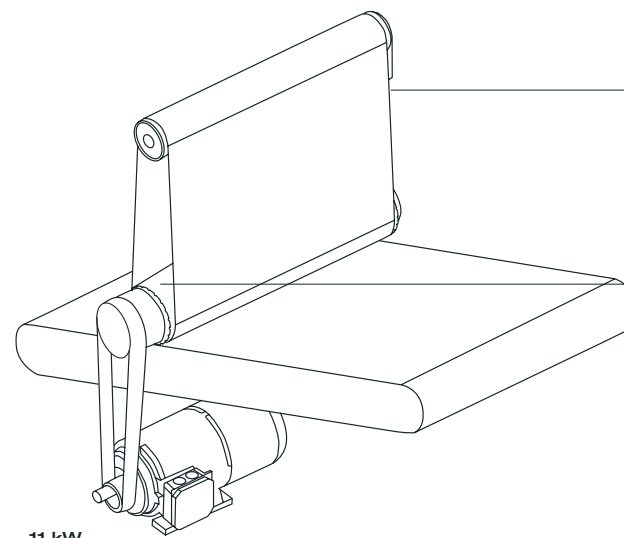

Quick manual reset of abrasive blocks wear.



__ learn more about the DM1100 ZC EVO option on page 22

scan the QR CODE to watch the machine demonstration video



EVO

ADVANCED DEBURRING FEATURES

EVO is improving our heavy-duty engineering principles, delivering powerful smooth deburring and edge rounding processes.

EVO is our next-level approach to sheet metal deburring. EVO is elegant design, keeping the integration of peripheral loading/unloading systems and automation equipment in mind.

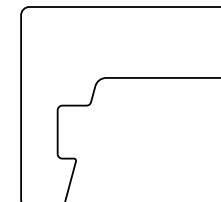

scan the QR CODE to watch EVO Line design and features



- _ heavy-duty engineering
- _ automated adjustments
- _ generous space for maintenance
- _ touchscreen control
- _ remote process monitoring
- _ interior lighting
- _ fixed working height

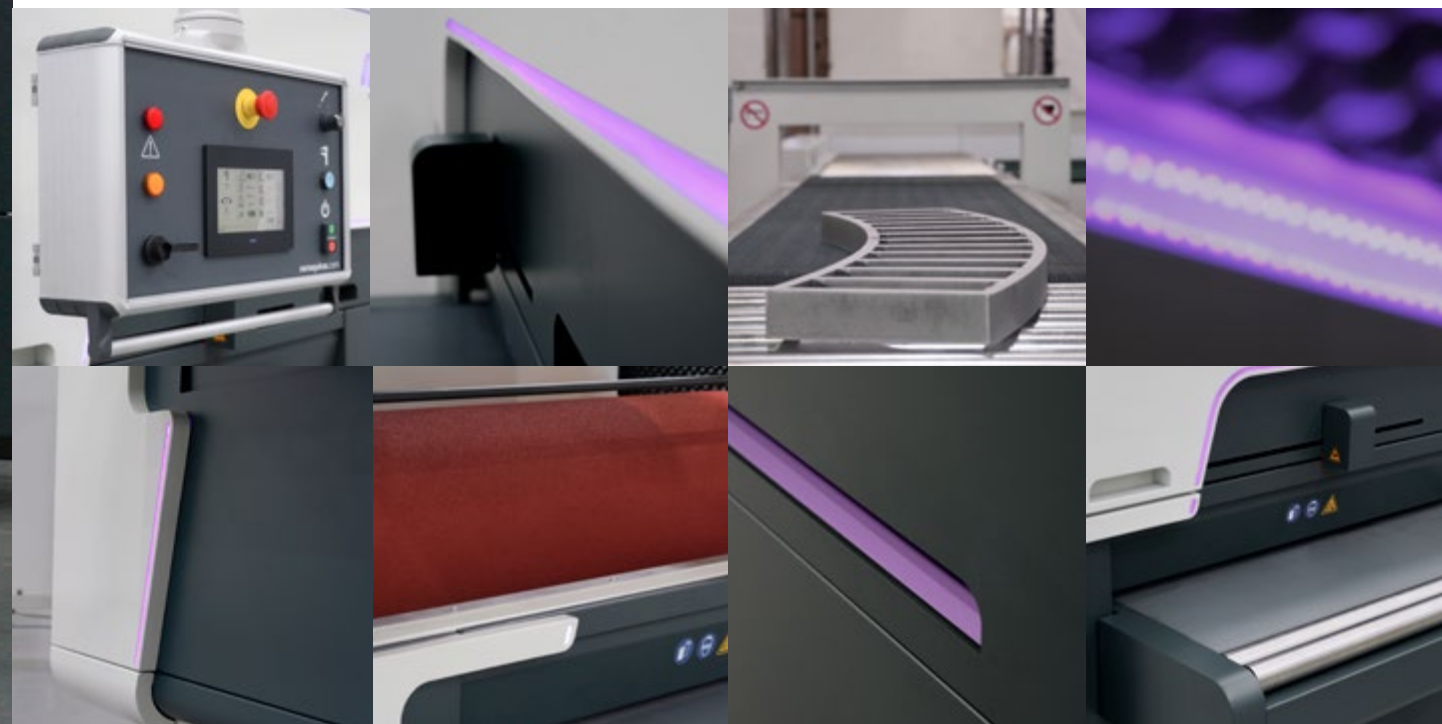

**DM1100 2C EVO / DOUBLE-SIDED
EDGE ROUNDING**

___ TOP LINE AUTOMATED

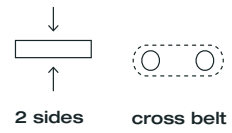

___ top and bottom
edge rounding of laser,
waterjet or punched
parts



___ single sided small
parts processing down
to 50x50mm thanks to
an additional conveyor
and support table

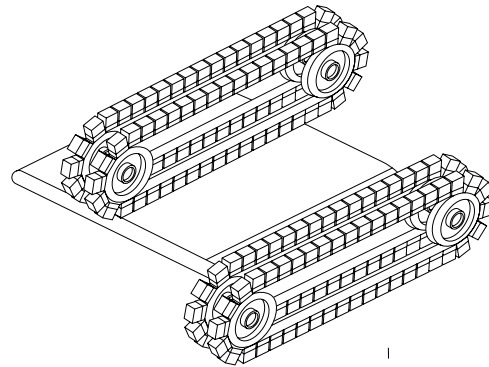

DM1100 2C EVO



scan the QR
CODE to watch
the machine
demonstration
video



DM1100 ZC EVO / DEBURRING AND EDGE ROUNDING
 TOP LINE AUTOMATED

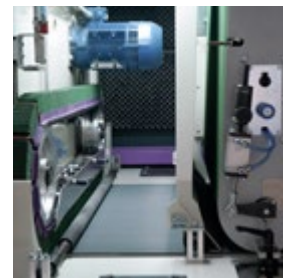
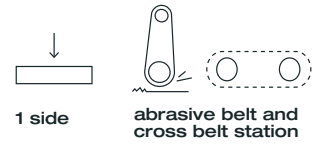

features a powerful deburring and edge rounding stations



strong edge rounding on parts down to (50x50mm)



special wide belt programs: deburring or surface finishing

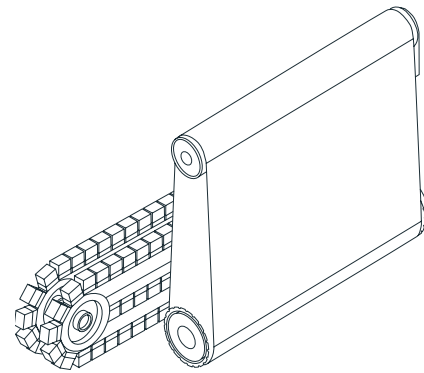

DM1100 ZC EVO

DM1100 ZC EVO
 TOP LINE

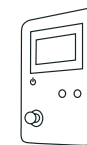
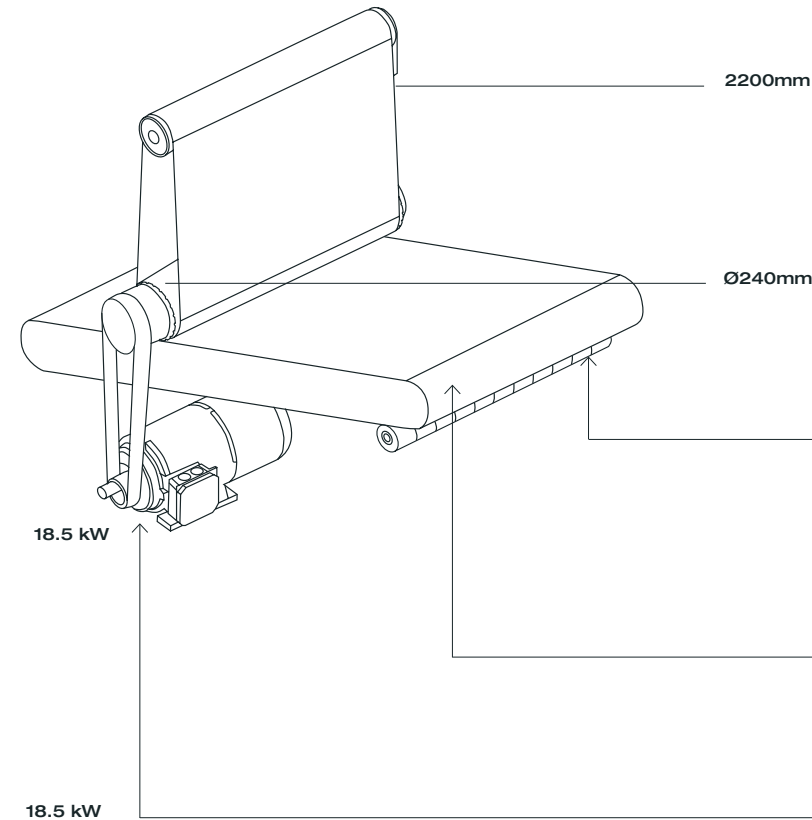

touchscreen with monitoring

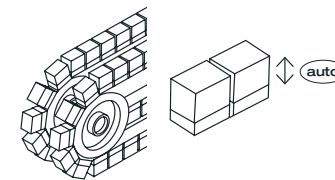

control

Most of the controls are on the touchscreen panel without the need to manually adjust the parameters. Includes statistics and errors during and about the operation.

auto abrasive compensation

Automatic abrasive wear compensation cycle to ensure uniform rounding.



scan the QR CODE to watch the machine demonstration video

DM1100 DC EVO / SLAG REMOVAL
 ___ HEAVY-DUTY AUTOMATED



___ heavy burrs deburring
 and edge rounding



___ possibility of regulating
 which stations will work
 and at what speed, the
 working pressure for
 both stations, floating
 drum on/off and drum
 oscillation

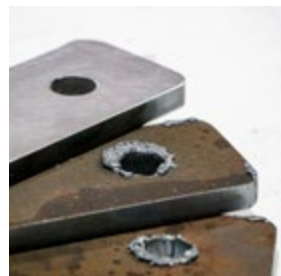

___ smooth edges
 two cross belts mounted
 with abrasive blocks
 running in opposite
 directions

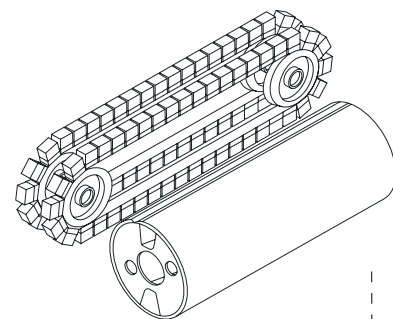

DM1100 DC EVO



scan the QR
 CODE to watch
 the machine
 demonstration
 video

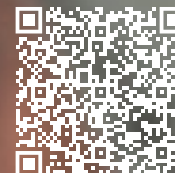

DEBURRING SOLUTIONS

DM1100 2Z EVO / SURFACE FINISHING

___ TOP LINE AUTOMATED



___ double or triple abrasive belt station plus finishing brush (2ZK and 3ZK)

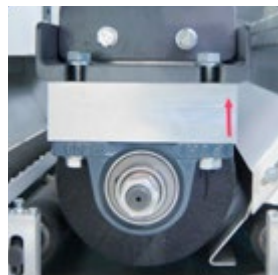

___ brush unit with option to be used with oscillation (150 strokes/min)

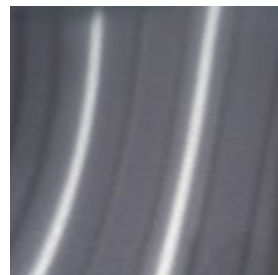

___ consistent and smooth surface finishing

dry version



water version

DMW1100 2Z EVO / SURFACE FINISHING

___ TOP LINE AUTOMATED

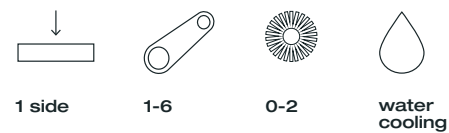

___ independent stainless steel compartments for each finishing station



___ the automatic filter assures the continuous renovation and monitoring of the filter paper cleanness

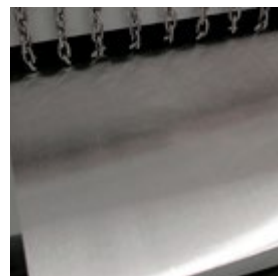

dry version

water version

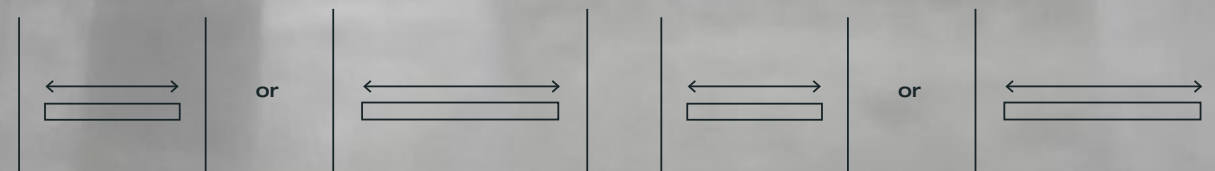

1100mm working capacity

1600mm working capacity

1100mm working capacity

1600mm working capacity

___ DM1100 2Z EVO

___ DM1600 2Z EVO

___ DMW1100 2Z EVO

___ DMW1600 2Z EVO



EDGE ROUNDING

| | C | C EVO |
|----------------------|------------------|------------------------------|
| category | job-shop version | automated functions |
| available width (mm) | 1100 1600 | 1100 1600 |
| operation type | single-sided | single-sided double-sided |

DEBURRING AND SURFACE FINISHING

| | Z | ZC | ZC EVO | DC EVO | Z EVO |
|-------------------------|------------------|------------------|------------------------------|------------------------------|--------------------|
| category | job-shop version | job-shop version | top line automated | heavy-duty automated | top line automated |
| available width (mm) | 1100 1600 | 1100 1600 | 1100 1600 | 1100 1600 | 1100 1600 |
| edge rounding mode | × | single-sided | single-sided double-sided | single-sided double-sided | × |
| deslagging level | ●○○ | ●○○ | ●●○ | ●●● | × |
| deburring level | ●●○ | ●●○ | ●●● | ●●● | × |
| surface finishing level | ●●○ | ●●○ | ●●● | × | ●●● |
| not suitable × | limited ●○○ | | adequate ●●○ | | optimal ●●● |

BEHIND THE SCENES

DISCOVER, TEST, SUCCEED

Delve into NS Máquinas machines and engineering by visiting NEXUS. Join us in our dedicated building to connect with our team, explore our production facilities, and witness the power of our machines firsthand in our showroom. Expect a personalized experience tailored to showcase what is NS Máquinas.



@nsmaquinas

SOME OF OUR REFERENCES



V1 / 2024
All rights reserved

NS MÁQUINAS