



Mark today, identify tomorrow

F.I.T. LASER (Funnel Integrated Technology Laser)

Ready to integrate & secure laser marking unit for production lines

F.I.T. LASER is an all-in-one solution that combines all the necessary components & settings to mark your parts in a simple, safe and competitive way within your production line.

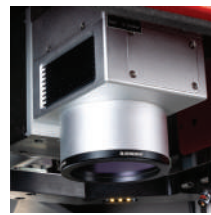

- SAFE
- RELIABLE
- COMPETITIVE

- ▶ Class 1 ready unit
- ▶ Compact
- ▶ Easy to integrate with a single connection to your network
- ▶ Combination of robust & proven standard equipment

2 modes of use are possible on the production line : either the **F.I.T. LASER** is mobile and the part to mark is fixed, or the opposite.

Part to mark

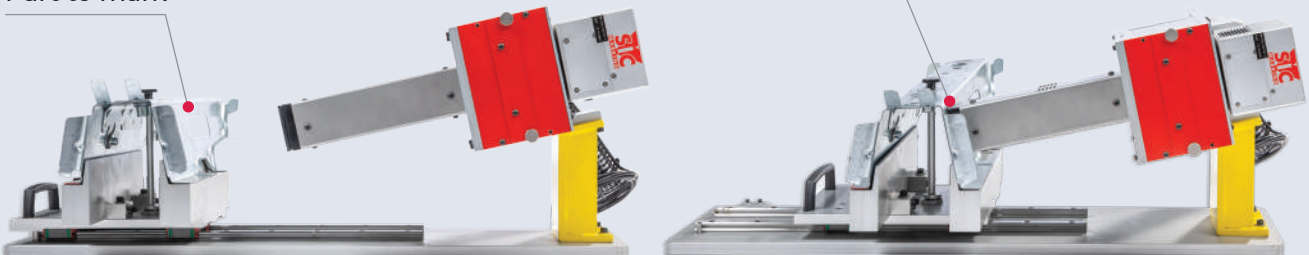

➔ A « Class 1 ready » laser unit

F.I.T. LASER links all the necessary elements to run in line a Class 1 laser unit to mark your parts. For the protection of the laser head, the laser beam is concealed inside a funnel, sealed at the end.

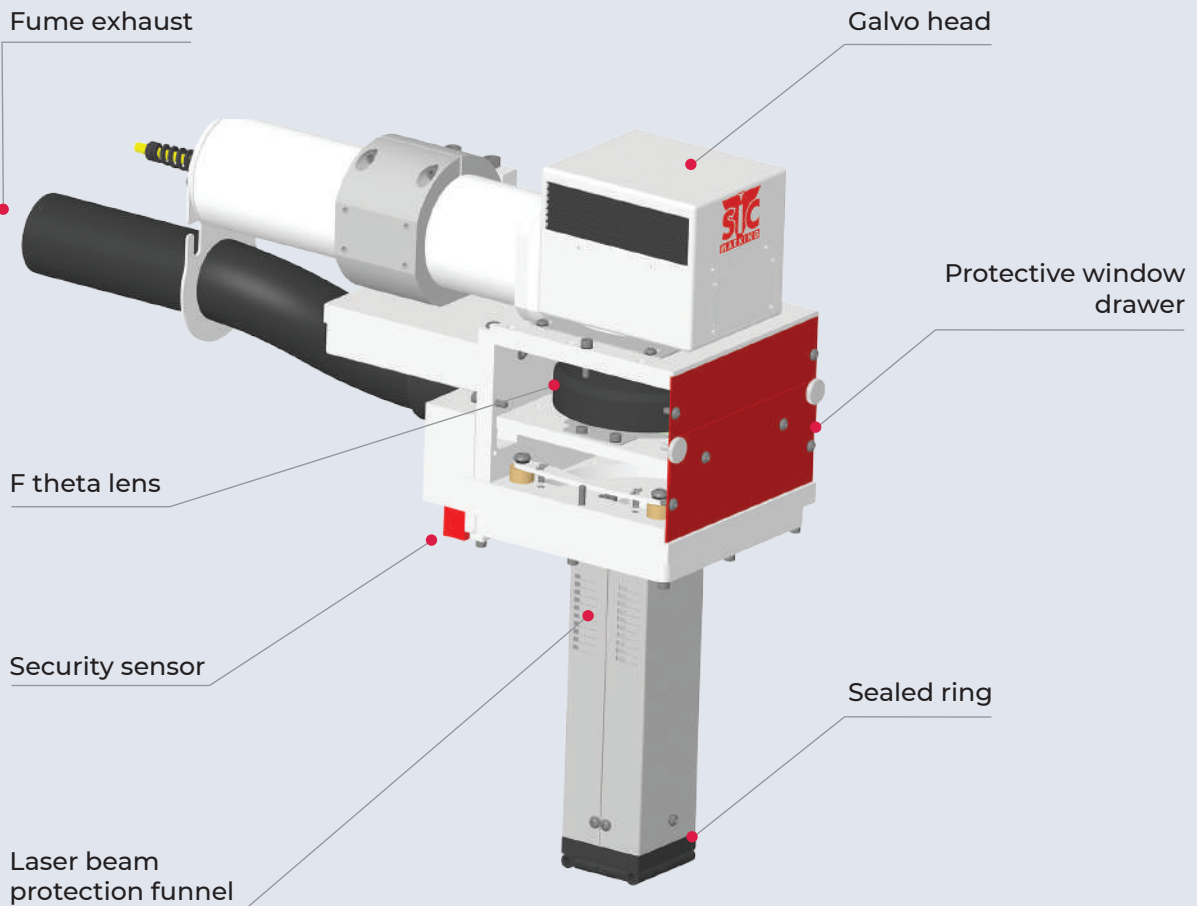

COMPACT & LIGHT (13 KG)

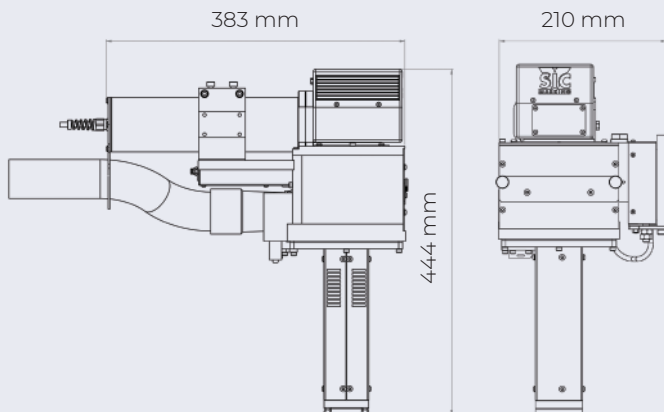

ADAPTED TO YOUR MARKING WINDOW NEEDS

3 dimensions* available (easily interchangeable)



* Other dimensions on demand

→ A single connection to your network

Connecting your PLC to **F.I.T. LASER** is extremely simple. A single Profinet or Ethernet IP connexion ensures a fast and easy integration.

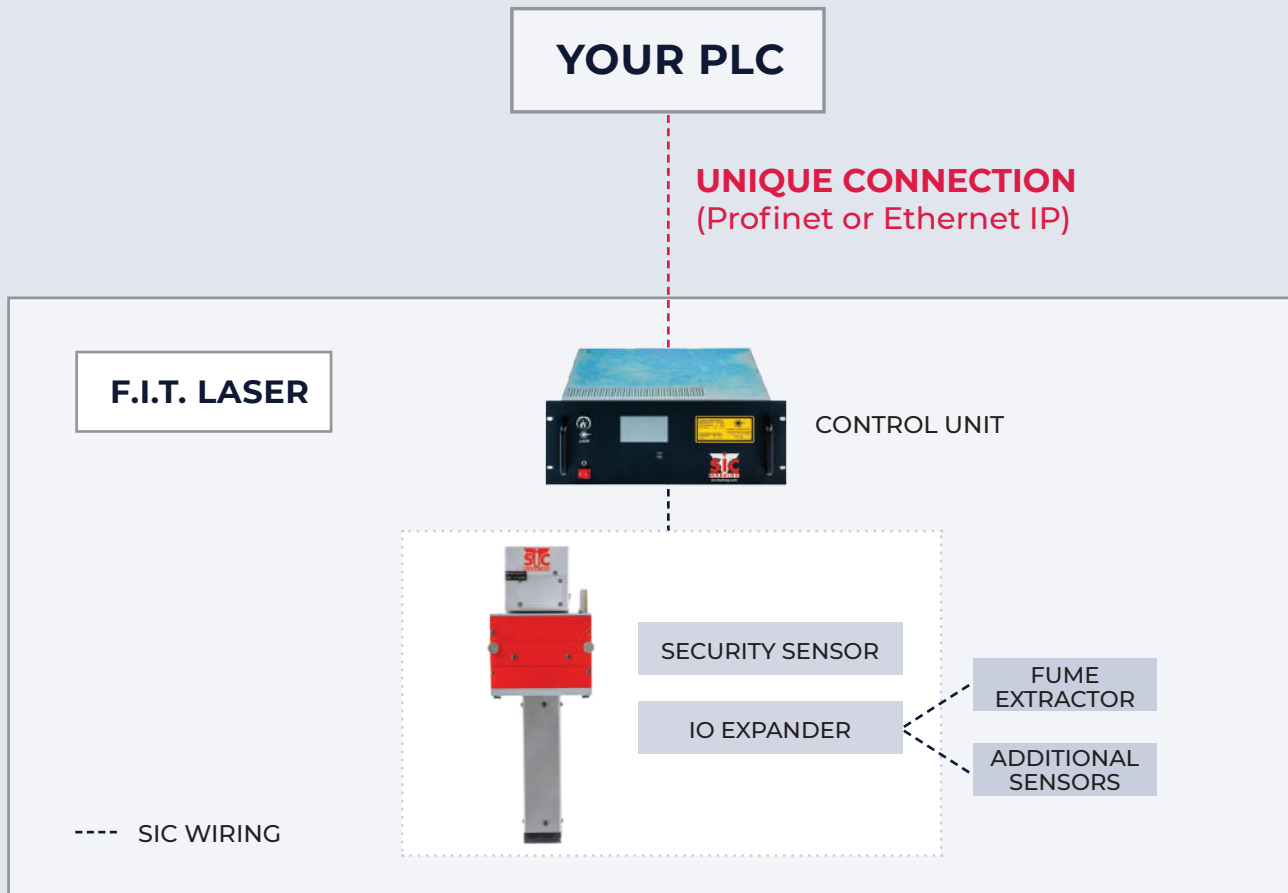

→ A perfect marking thanks to an integrated autofocus

Integrated compensation within the funnel ensures a perfect marking. The funnel is designed to absorb variations in part dimensions. This device avoids the integration of a costly & fragile electronic autofocus.

- This mechanical autofocus compensates the variations of set-up, piece or part dimensions, range of tolerance, robot moves...
- This compensation system is the guarantee of an ideal focal distance to the marking area for a perfect marking.

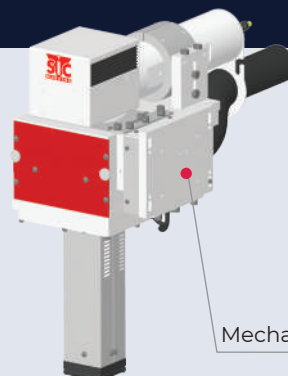

Mechanical compensator

→ F.I.T. LASER is designed for production environments

To ensure accuracy & performance over time, **F.I.T LASER** integrates specific features & accessories ensuring the protection & optimal operation of the unit.

A SPECIFIC CHASSIS CAN HOST THE COMMAND, VACUUM & ELECTRICAL UNITS

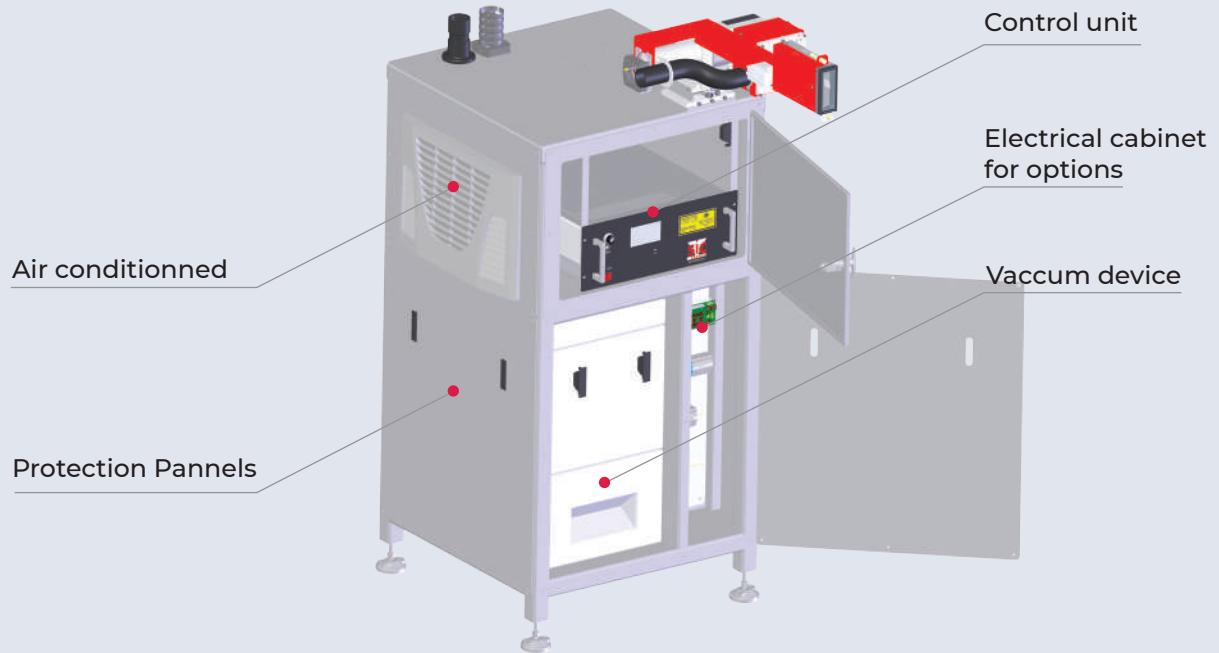

A PROTECTIVE GLASS DRAWER, EASILY ACCESSIBLE FOR CLEANING

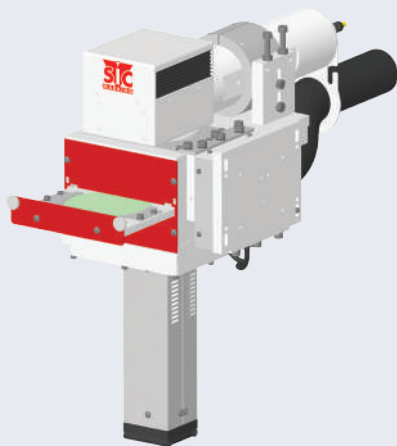

SPECIFIC AIRFLOW & ASPIRATION TO DEFLECT FUMES AND SPARKS FROM THE LASER HEAD

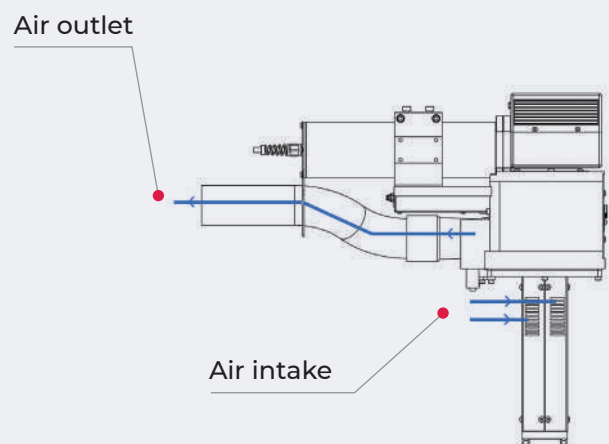

CONTACT US



Mark today, identify tomorrow