

hyperMILL[®]

TURNING Solutions



CAD/CAM Solutions
FOR TURNING OPERATIONS



MILL-TURN Machining



TURN-MILL Machining



TURNING

hyperMILL® TURNING Solutions: Turning Ideas into Success

Turning operations are at the core of today’s manufacturing industry. Our “hyperMILL® TURNING Solutions” combine various turning strategies, from turning with a turret to turn-milling on multitasking machines and mill-turning on machining centers. Manual programming on the controller is an unproductive and error-prone process, which is why it is no longer viable for most applications.

Innovative CAD/CAM Solutions for Turning and Multitasking Processes

Create optimized NC codes with hyperMILL®! The CAD/CAM software offers comprehensive strategies for turning, turn-milling and mill-turning that offer perfect toolpaths and innovative CAM technologies. Safety comes first. This is why hyperMILL® VIRTUAL Machining simulates and optimizes the generated NC code. Standardize and accelerate programming with automation solutions in hyperMILL®. Discover numerous advantages for your production and start programming with hyperMILL® TURNING Solutions.

Turning Strategies Included in hyperMILL® TURNING Solutions

- Roughing
- Contour-parallel roughing
- Finishing
- Groove turning
- Groove plunging/Parting off
- Groove finishing
- Thread cutting
- Comprehensive drilling operations
- High-performance turning
- 3-axis simultaneous roughing
- 3-axis simultaneous finishing

Comprehensive strategy package

hyperMILL® empowers you to program your production processes with ease. Turning, milling, drilling – handle all jobs in an intuitive operating environment.

Powerful tool database

Benefit from our extensive tool database for all tool types. The hyperMILL® TOOL Builder brings ease and convenience to building your 3D tool.

Simple stock tracking

Stock tracking is calculated for all turning and milling operations, while taking into account the upstream machining steps.

Optimized postprocessors

A perfectly adapted postprocessor generates NC codes for safe turning and milling operations in a single NC program.

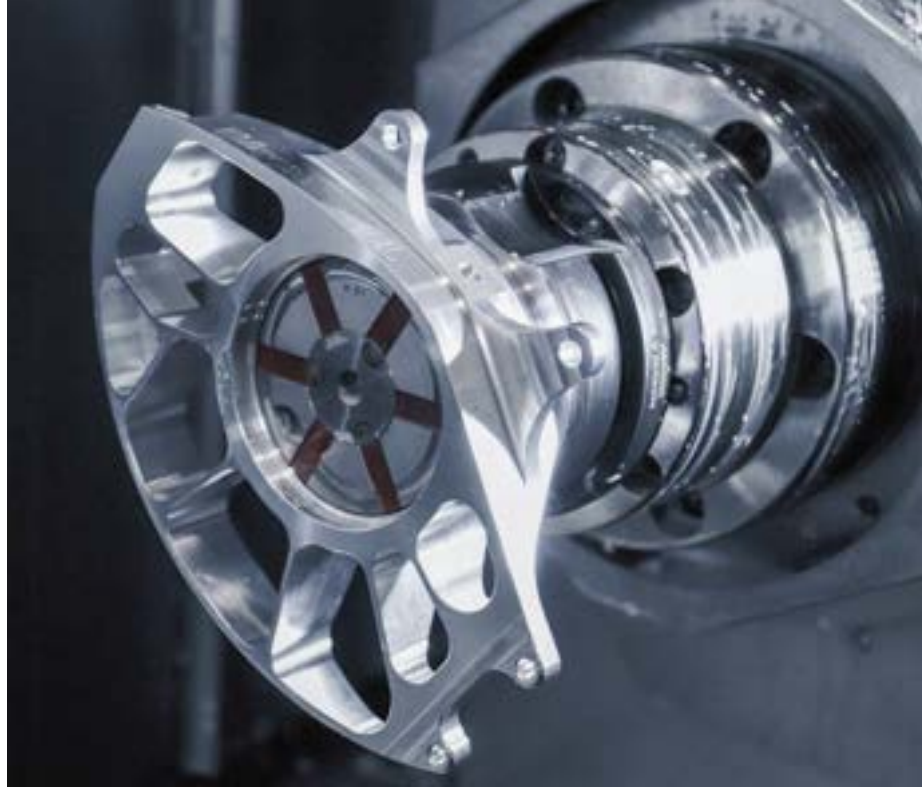

“We consider *hyperMILL*® TURNING Solutions one of our top priorities and are therefore driving development at great speed.”

Daniel Hausinger, Product Manager, OPEN MIND Technologies AG

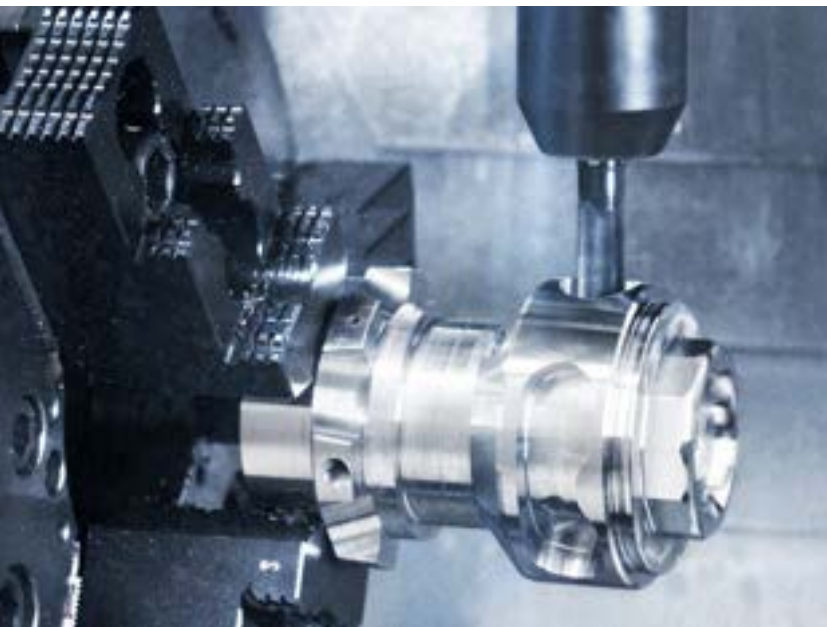



hyperMILL® MILL-TURN Machining: High-end milling meets turning

Use turning operations to maximize the efficiency of your machining center. Our turning strategies augment the capabilities of your mill-turning center many times over when combined with powerful milling strategies. You benefit from greater efficiency, precision production, and maximum safety during complete machining using *hyperMILL*®. With the powerful CAM strategies for both technologies, not only will you easily master programming tasks, but you will also minimize operations and effectively reduce setup times.



Use proven *hyperMILL*® milling strategies for 2.5D, 3D, and 5-axis machining

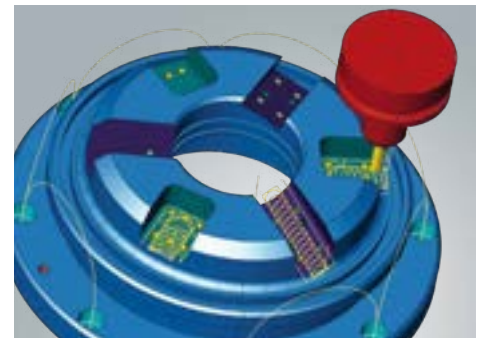

Detect and program pockets and holes with feature and macro technology



5-axis simultaneous and multi-axis indexing bring maximum flexibility to machining



Rotationally symmetrical inner contours are also ideally suited for turning operations



Scan this for more information and exciting content on *hyperMILL*® MILL-TURN Machining



Complete machining on the CNC machine – milling and turning at the same workstation

The combination of milling and turning opens up vast potential for the production of rotationally symmetrical machined parts. The additional use of turning operations often proves extremely efficient. In *hyperMILL*®, milling and turning are combined seamlessly. This not only enables intuitive operation, but it also ensures that high-quality toolpaths are generated.

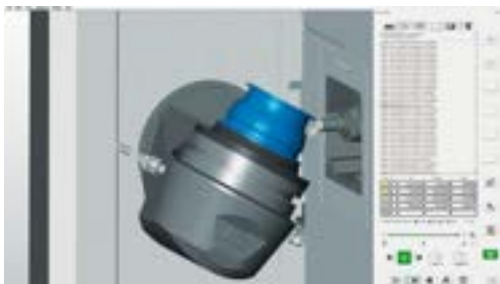

Maximum safety – simulation and optimization

For large, complex and expensive components, precision results at the first attempt are essential. *hyperMILL*® VIRTUAL Machining does just that. This is because the NC code is created based on a digital twin of the actual machine, and collision checks, simulations, and analyses are based on the final NC code. As a result, you know exactly what will happen on the actual machine. The NC Optimizer automatically optimizes the NC program by adapting it perfectly to the kinematic characteristics of the selected machine. This ensures that the technically most viable, collision-free inclination is determined and the travel movements are optimized. In addition, efficient and highly accurate results are guaranteed, which is a key factor in keeping costs low while maximizing safety.

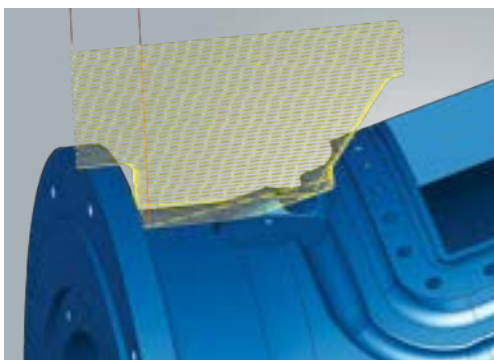

HPC machining on mill-turn machines

Large components, high cutting volumes, and demanding materials are common challenges in mill-turn machining. High-performance turning and milling offers you numerous advantages here. With *hyperMILL*®, trochoidal toolpaths are generated with optimized connecting paths – without the need for additional programming. The advantages for your production include robust and efficient machining processes, especially when it comes to difficult-to-machine materials.

Easily program 3-axis simultaneous turning

hyperMILL® enables the convenient and safe creation of simultaneous toolpaths, which opens up new options for machining complex geometries. You also benefit from improved tool utilization. For even better performance, simultaneous turning can also be combined with the HPC option.

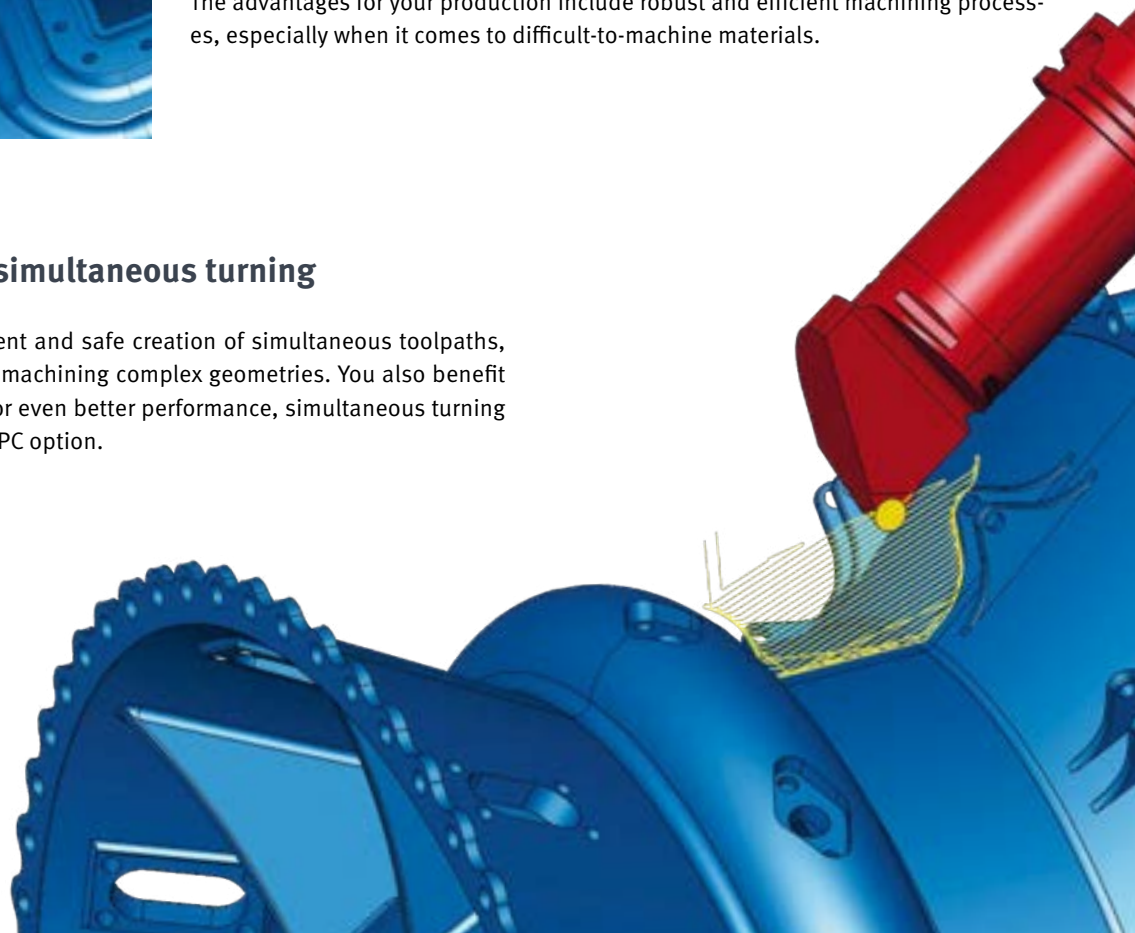



hyperMILL® TURN-MILL Machining: CAM programming for multitasking machines made easy

Programming turn-mill centers is a highly demanding challenge for programmers. Experience is crucial to guarantee safe processing on the machine. A suitable CAM system can make all the difference here. *hyperMILL*® TURN-MILL Machining provides you with a CAM solution that offers efficient toolpaths and provides reliable simulation for these collision-prone machines.

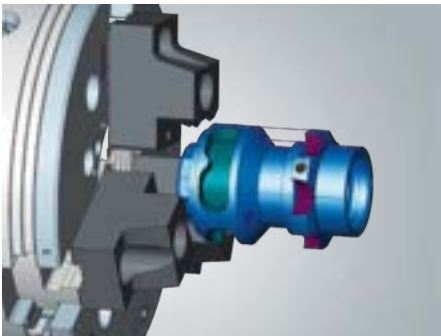

Feature and macro technology: Program pockets, holes and turning contours with just a few clicks



Milling with proven HPC technology: high metal removal rates, gentle on tools, and extremely efficient

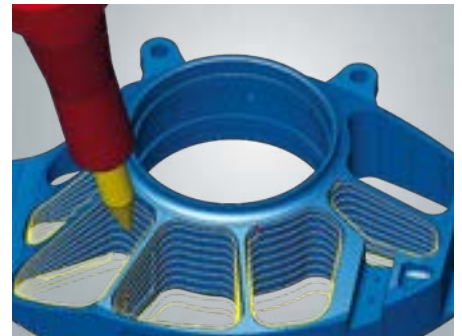

High time savings can also be achieved in turn-milling thanks to the use of barrel cutters



Learn more about *hyperMILL*® TURN-MILL Machining

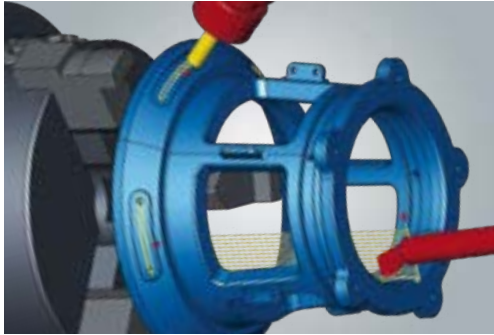

Complete machining on the turn-mill machine – turning, milling, and drilling

Modern turn-mill centers are indispensable in today's manufacturing arena. Rely on efficient CAM strategies for turning, milling, and drilling in a user-friendly environment. All tools, including intended uses and technology parameters, are stored in a database for easy retrieval. Optimize your production processes with *hyperMILL*!

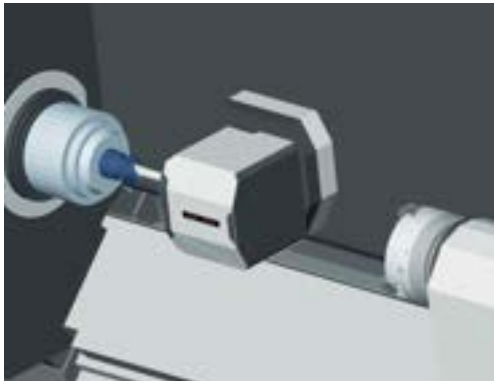

Main and counter spindle machining with component transfer

With *hyperMILL*®, you can conveniently program components on machines with main and counter spindle. Simply define the machining jobs in the so-called “Main Spindle” and “Counter Spindle” containers to assign them to the appropriate machining side. The component or bar stock can thus be easily transferred by means of a transfer job with or without parting.

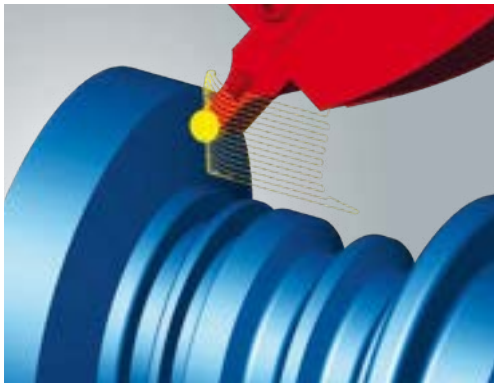

Simultaneous turning programmed with ease

hyperMILL® offers you strategies for 3-axis simultaneous roughing and finishing. Unlock new potential for machining undercuts and complex geometries. Increase the efficiency of roughing difficult-to-cut materials with the HPC option.

HPC turning on turn-mill machines

Benefit from high-performance turning without any additional programming effort. Use trochoidal toolpaths with optimized connecting paths for more robust and efficient machining processes, especially when handling difficult-to-machine material.

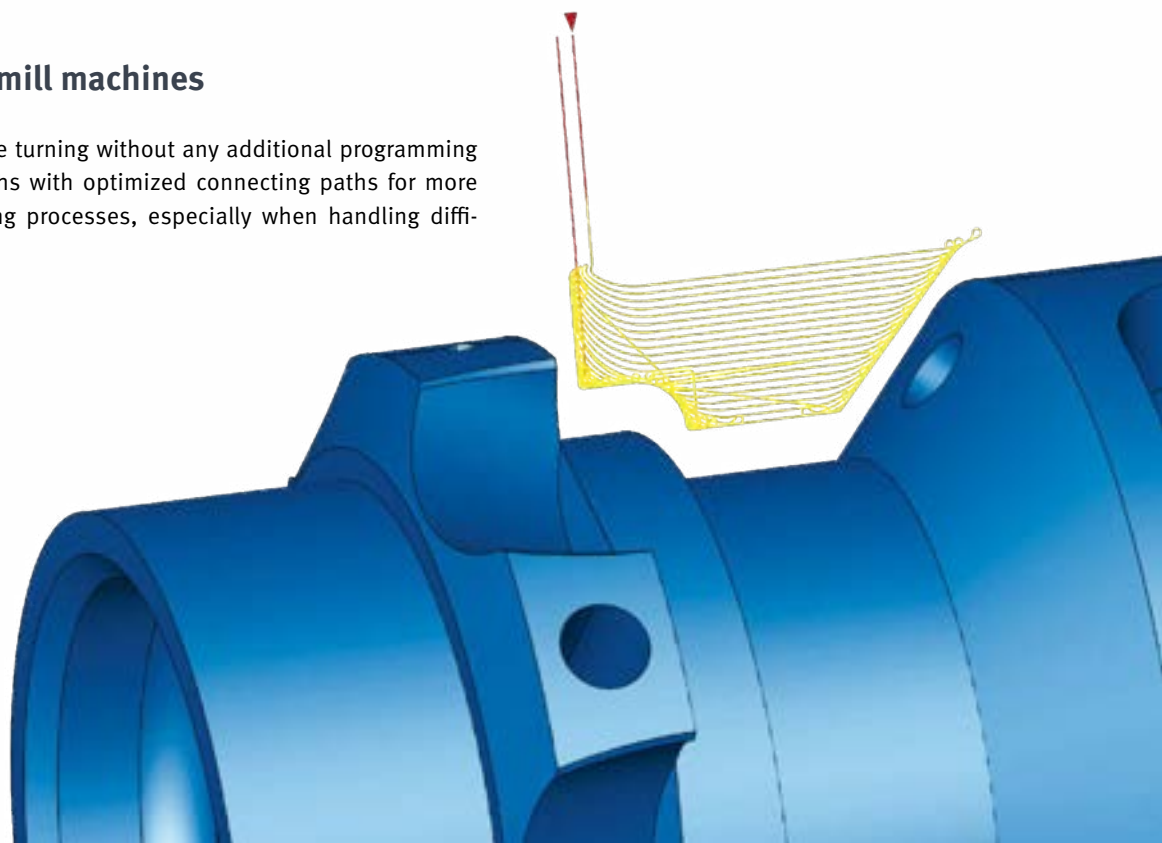



hyperMILL® TURNING: simple and productive turning strategies

Simple and productive – that basically sums up turning operations. Use *hyperMILL®* TURNING to program and simulate turning and drilling processes with ease. Intuitive strategies and functions for roughing, finishing, and grooving make this a breeze.

Turning and drilling with a turret assembly

Facing, roughing, finishing, and drilling – turning involves numerous operations, and the turret holds all required tools. Precise mapping of the turret in *hyperMILL®* is crucial for reliable machining. In *hyperMILL®* VIRTUAL Machining, the machine and all tools are mapped in detail and used for NC code simulation. The turret can be equipped conveniently with holders and tools directly in the virtual machine.



Do you want
to learn more about
hyperMILL® TURNING?
Simply scan this!





CAD for CAM – generate undercuts, radii, and chamfers

DIN undercuts are part of the daily routine of every lathe operator. Thanks to the intuitive CAD function, you can generate undercuts of any type in seconds. You can also create or remove chamfers and radii globally for the entire turning contour at the touch of a button.

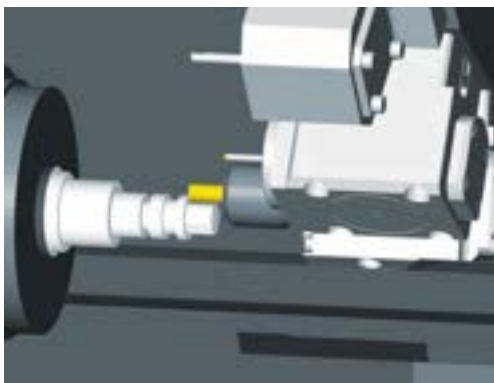

Easy-to-use polar C-X interpolation

Use the C-X interpolation with driven tools to be even more flexible during machining. This allows you to respond effortlessly to axis limits or missing linear axes on your machine.

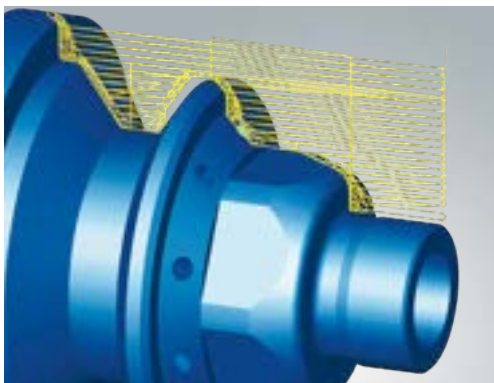

HPC turning

Discover the numerous advantages of high-performance turning at the touch of a button. Use trochoidal toolpaths with optimized connecting paths for more robust and efficient machining processes, especially when handling difficult-to-machine material. Improve the turning performance without any additional programming effort!



NC code generation and simulation

Thanks to *hyperMILL*® VIRTUAL Machining and the integrated digital machine twin, the NC code is created with maximum reliability. Collision checking, simulation, and analyses are based on the actual NC code, so you know exactly what will happen on the actual machine.

Efficient and reliable: High-Performance Turning

With *hyperMILL*® MAXX Machining, the concept of trochoidal milling can also be applied to turning operations. HPC turning delivers clear advantages in terms of productivity, process reliability, and time savings, especially when working with difficult-to-machine materials. Better yet, all of this comes without any additional programming effort.

The connecting paths between the individual toolpaths as well as the approach and retract movements are perfectly adapted to the respective machining application. This not only reduces the machining time, but also increases the tool life. Homogeneous machine movements reduce the load on the individual axes of the machine tool.

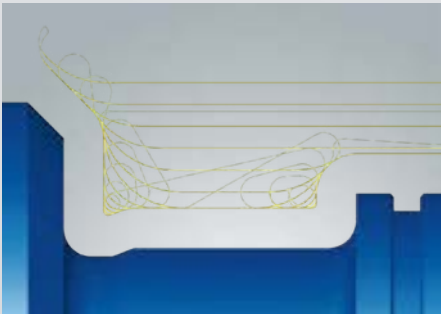

Intelligent algorithms calculate the trochoidal toolpaths with optimized connecting paths

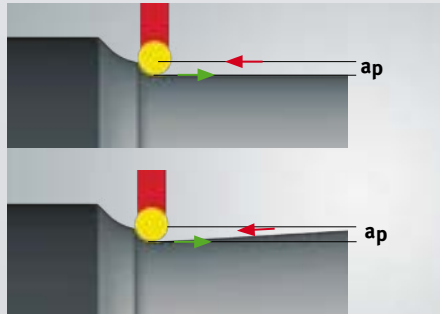

The machining takes place in a uniform direction or in a zigzag pattern. The infeed takes place in a linear or ramp-like movement.



The combination of HPC and simultaneous machining combines all the advantages of both technologies

Features

- Increased process reliability
- Improved productivity
- High material removal
- Simple programming
- Reduced number of tools needed
- Tool-friendly machining
- Uses proven HPC technology from Celeritive™



Learn more about
hyperMILL®'s
HPC technology

Maximum flexibility: 3-axis Simultaneous Turning

Simultaneous machining makes turning on machines with a pivoting head on the third axis even more efficient. Simultaneous adjustment of the approach angle during the turning operation allows you to produce complex workpiece geometries and undercuts in a single go.

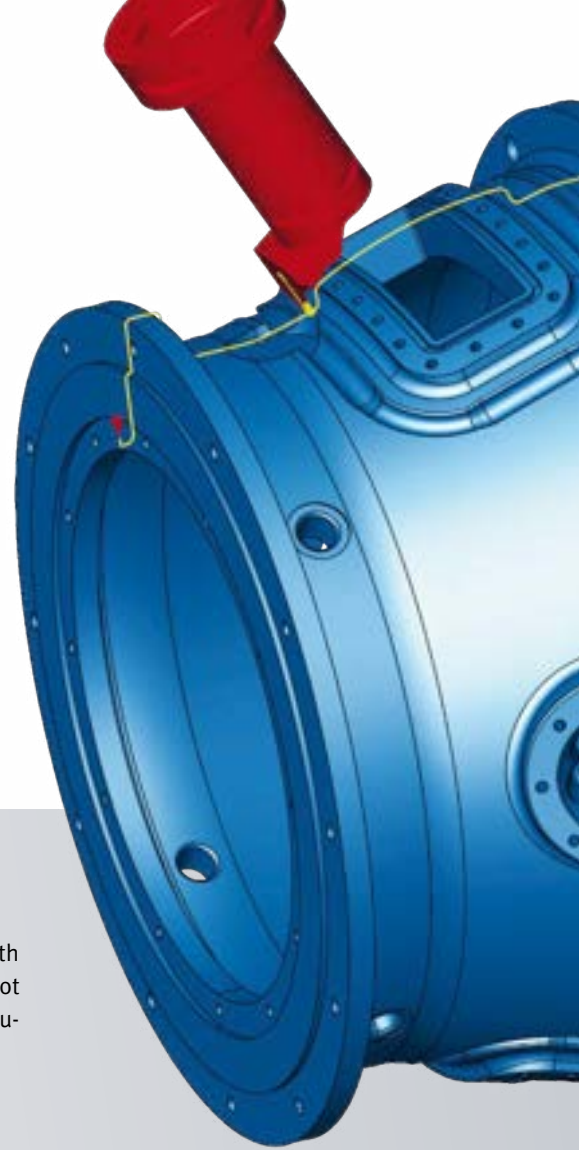

Simultaneous turning programmed with ease

Special strategies for simultaneous roughing and finishing make programming both easy and convenient. The sequential movements of the B-axis are defined by pivot points or synchronization lines, and the simultaneous movement is calculated automatically.

Features

- Machine complex contours in a single operation
- Optimal tool use
- Increased tool life
- Fewer tool changes
- Simple to program
- For machines with a pivoting head on the third axis
- Fully checked for collisions

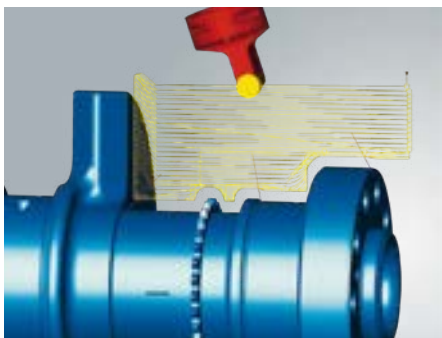

Roughing: The innovative approach, which involves using a simultaneous B-axis during roughing, offers you numerous advantages such as optimized tool utilization and increased tool life



Finishing: The simultaneous movement of the B-axis allows complex contours to be finished in a single operation, preventing tool changes and mismatches

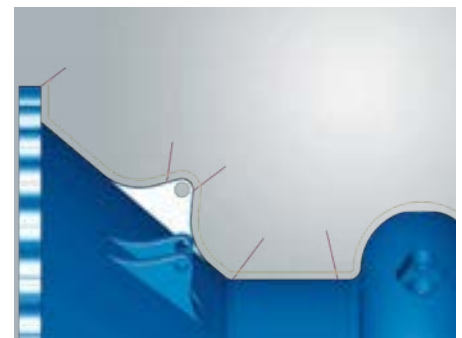

Easy to program: Define the simultaneous swivel movement of the machine using synchronization lines or pivot points

HEADQUARTERS

OPEN MIND Technologies AG
Argelsrieder Feld 5 • 82234 Wessling • Germany
Phone: +49 8153 933-500
E-mail: Info.Europe@openmind-tech.com
Support.Europe@openmind-tech.com

PORTUGAL

OPEN MIND Technologies Portugal, Unipessoal, Lda
Edifício Centro de Negócios MAPER • Fração N e O
Estr. Nacional 242, Km 9,2 • 2430-074 Marinha Grande • Portugal
Phone: +351 244 023 359
E-mail: Info.Portugal@openmind-tech.com

SWEDEN

OPEN MIND Technologies Scandinavia AB
Älvhålegatan 34
417 28 Gothenburg • Sweden
E-mail: Info.Scandinavia@openmind-tech.com

UK

OPEN MIND Technologies UK Ltd.
Unit 3 • Bicester Business Park
Telford Road • Bicester • Oxfordshire OX26 4LN • UK
Phone: +44 1869 290003
E-mail: Info.UK@openmind-tech.com

USA

OPEN MIND Technologies USA, Inc.
1492 Highland Avenue, Unit 3 • Needham MA 02492 • USA
Phone: +1 888 516-1232
E-mail: Info.Americas@openmind-tech.com

BRAZIL

OPEN MIND Tecnologia Brasil LTDA
Av. Andromeda, 885 SL2021
06473-000 • Alphaville Empresarial
Barueri • Sao Paulo • Brasil
Phone: +55 11 2424 8580
E-mail: Info.Brazil@openmind-tech.com

ASIA PACIFIC

OPEN MIND Technologies Asia Pacific Pte. Ltd.
MOVA Building, 22 Jalan Kilang • #03-00
Singapore 159419 • Singapore
Phone: +65 6742 95-56
E-mail: Info.Asia@openmind-tech.com

CHINA

OPEN MIND Software Technologies China Co., Ltd.
Suite 1608 • Zhong Rong International Plaza
No. 1088 South Pudong Road
Shanghai 200120 • China
Phone: +86 21 588765-72
E-mail: Info.China@openmind-tech.com

INDIA

OPEN MIND CADCAM Technologies India Pvt. Ltd.
No. 610 and 611 • 6th Floor • 'B' Wing
No. 6, Mittal Tower, M.G. Road
Bangalore 560001 • Karnataka • India
Phone: +91 80 2676 6999
E-mail: Info.India@openmind-tech.com

JAPAN

OPEN MIND Technologies Japan K.K.
Albergo Musashino B101, 3-2-1 Nishikubo
Musashino-shi • Tokyo 180-0013 • Japan
Phone: +81-50-5370-1018
E-mail: Info.Japan@openmind-tech.com

TAIWAN

OPEN MIND Technologies Taiwan Inc.
Rm. F, 4F., No.1, Yuandong Rd., Banqiao Dist.
New Taipei City 22063 • Taiwan
Phone: +886 2 2957-6898
E-mail: Info.Taiwan@openmind-tech.com

OPEN MIND Technologies AG is represented worldwide with own subsidiaries and through competent partners and is a member of the Mensch und Maschine technology group, www.mum.de



We push machining to the limit

www.openmind-tech.com