

GENERAL CATALOG

- ● ● SWISS TYPE AUTOMATIC LATHE equipped with star motion control system
- ● ○ CNC SWISS TYPE AUTOMATIC LATHE
- ○ ○ CNC AUTOMATIC LATHE

STAR MICRONICS CO., LTD.

Machine Tools Division

1500-34 Kitanoya, Misawa, Kikugawa, Shizuoka, 439-0023 Japan
 TEL.+81-537-36-5594 FAX.+81-537-36-5607
<https://www.star-m.jp/eng/>

Star Group

Star CNC Machine Tool Corporation
 123 Powerhouse Road, Roslyn Heights, NY 11577, U.S.A.
 TEL.+1-516-484-0500 FAX.+1-516-484-5820

Star Micronics GB Limited
 Unit 1 Riverlands Business Park Raynesway DERBY DE21 7BZ
 TEL.+44-1332-86-44-55 FAX.+44-1332-86-40-05

Star Micronics GmbH
 Robert-Grob-Str. 1, D-75305 Neuenbürg, Germany
 TEL.+49-7082-7920-0 FAX.+49-7082-7920-20

Star Micronics AG
 Lauetstrasse 3, CH-8112 Otelfingen, Switzerland
 TEL.+41-43-411-60-60 FAX.+41-43-411-60-66

Star Machine Tool France
 90 Allee de Glaisy, ZI.74300 Thyez Haute Savoie, France
 TEL.+33-450-96-05-97 FAX.+33-450-96-91-54

Shanghai Xingang Machinery Co., Ltd.
 2F, 229 Fute Rd. N. The China (Shanghai) Pilot Free Trade Zone
 TEL.+86-21-5868-2100 FAX.+86-21-5868-2101

Star Micronics (Thailand) Co., Ltd.
 289/23 M.13 Soi Kingkaew 25/1, Kingkaew Rd., T.Rachathewa A.Bangolee Samutprakarn 10540, Thailand
 TEL.+66-2-186-8945-47 FAX.+66-2-183-7845

Note)
 The machining capacities apply to SUS303 (SV series : S45C) material.
 The machining capacities may differ from listed values depending on the machining conditions, such as the material to be machined or the tools to be used.



※ Design features, specifications and technical execution are subject to change without prior notice.
 ※ This product is an export control item subject to the foreign exchange and foreign trade laws.
 Thus, before exporting this product, or taking it overseas, contact your STAR MICRONICS dealer.

User Oriented Concept

INDEX

● Sub spindle ● Front-end working tool ● Front/Rear-end working tool ● Rear-end working tool

ST	38	38 mm 350mm				6,250kg 3,477 Overall height : 1,865mm	PAGE 05
	20	20 mm 350mm				4,850kg 2,988 Overall height : 1,845mm	PAGE 06
SX	38	38 mm 320mm Max. 95mm				5,800kg 2,955 Overall height : 1,975mm	PAGE 07
	20R	20 mm 205mm Max. 50mm				4,150kg 2,730 Overall height : 1,865mm	PAGE 08
SV	20	20 mm 205mm				3,400kg 2,588 Overall height : 1,765mm	PAGE 09
	12RII	13 mm 135mm Max. 30mm				2,100kg 1,995 Overall height : 1,700mm	PAGE 10
SR	38 type B	38 mm 320mm Max. 95mm				4,300kg 2,740 Overall height : 2,120mm	PAGE 11
	20RIV type A type B	20 mm 205mm Max. 50mm				2,600kg 2,334 Overall height : 1,700mm	PAGE 12
	32JIII type A type B NEW	32 mm 320mm Max. 80mm	Cartridge-type 5-spindle cross drilling unit (ER20) ★ type B ☆ type A			4,100kg 2,690 Overall height : 1,780mm	PAGE 04

SR	20JII type A type B	20 mm 205mm Max. 50mm	5-spindle cross drilling unit ER16/20 ★ type B ☆ type A			2,750kg 2,250 Overall height : 1,700mm	PAGE 13
	10J type C	10 mm 135mm				1,400kg 1,865 Overall height : 1,695mm	PAGE 14
SL	7 10 NEW	10 mm 135mm	Cartridge-type 5-spindle cross drilling unit 			1,600kg 1,865 Overall height : 1,815mm	PAGE 03
	20R type G	20 mm 205mm Max. 50mm	4-spindle cross drilling unit 			Type G 1,750kg 2,070 Overall height : 1,760mm	PAGE 15 · 16
SB	16R type G	16 mm 205mm Max. 50mm	* type G/N Only 			Type N 1,700kg 2,070 Overall height : 1,760mm	PAGE 15 · 16
	12R type G	13 mm 205mm Max. 30mm	5-spindle cross drilling unit 			Type C 1,650kg 2,070 Overall height : 1,760mm	PAGE 15 · 16
	20R type N	20 mm Max. 55mm	* type G/N Only 			Type C 1,650kg 2,070 Overall height : 1,760mm	PAGE 15 · 16
	20R type C	20 mm 205mm	Cartridge-type 5-spindle cross drilling unit 7.5-spindle high-speed 			6,600kg 2,800 Overall height : 2,130mm	PAGE 17
SK	16R type C	16 mm 205mm	* type G/N Only 				
	51 type A	51 mm 125mm					

High-spec and Compactness
A New Generation Machine Specialized in Small Diameter Processing from Star Micronics

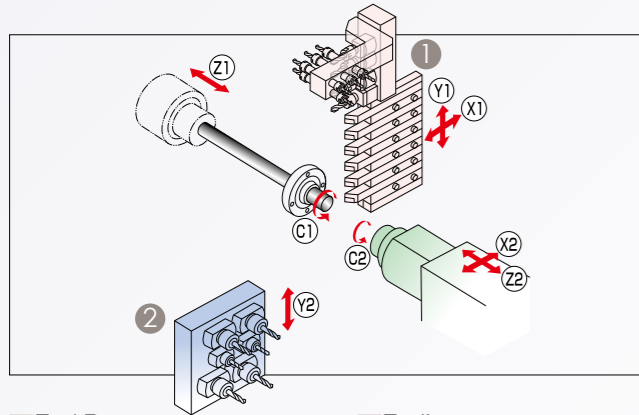

▼ Tool Post	
1	Turning tool 6 tools
	Front-end working tool 4 or 6 tools
	Rear-end working tool 4 or 6 tools
	Power-driven tool (ER11) 1 tools
	Cartridge type 4 Pos

▼ Tooling	
2	Rear-end working tool 6 tools
	(Stationary tool max.6 tools)
	(Power-driven tool max.4 tools)

■ Specifications

Item	Specifications
Max. machining diameter	φ 10mm(25/64in)
Max. headstock stroke	Stationary G.B. type 135mm(5-5/16in) R.G.B. type 105mm(4-9/64in) R.M.G.B. type 75mm(2-61/64in)
Number of turning tools	6 tools
Tool shank	□8mm / □10mm
4-spindle	φ 16mm(5/8in) × 4 tools
6-spindle	φ 16mm(5/8in) × 4 tools
Sleeve holder	φ 22mm(55/64in) × 2 tools
Max. drilling capability	φ 6mm(15/64in)
Max. tapping capability	M5 × P0.8
Number of tools	Cross milling 1 tools(ER11) + Cartridge type 4 positions
Max. drilling capability	φ 5mm(3/16in)
Max. tapping capability	M4 × P0.7
Spindle speed	Max. 12,000min ⁻¹
Drive motor	1.0kW(continuous) / 1.2kW(5min./30%ED)
Main spindle indexing angle	C-axis control
Main spindle speed	with Stationary G.B. Max. 18,000min ⁻¹ with Revolving G.B. unit Max. 15,000min ⁻¹
Main spindle motor	3.7kW(continuous) / 5.5kW(10min./25%ED)
Coolant tank capacity	109ℓ
Dimensions (W×D×H)	1,865 × 795 × 1,815mm
Weight	1,600kg

■ Backworking Attachment

Item	Specifications
Max. chucking diameter	φ 10mm(25/64in)
Max. length for front ejection	70mm(2-3/4in)*
Max. parts projection length	20mm(25/32in)*
Number of tools	6 tools
Max. drilling capability	Stationary tool φ 6mm(15/64in) Power driven tool φ 5mm(3/16in)
Max. tapping capability	Stationary tool M5 × P0.8 Power driven tool M4 × P0.7
Spindle speed	Max. 12,000min ⁻¹
Drive motor	1.0kW(continuous) / 1.2kW(5min./30%ED)
Sub spindle indexing angle	C-axis control
Sub spindle speed	Max. 12,000min ⁻¹
Sub spindle motor	0.55kW(continuous) / 1.1kW(15min./40%ED)

* The specification value depending on the type of sub-spindle chuck. Please confirm the details with the sales manager.

Increased flexibility in response to Market demands
for greater capability for large diameter machining



Illustration: 5-spindle cross drilling unit / type B

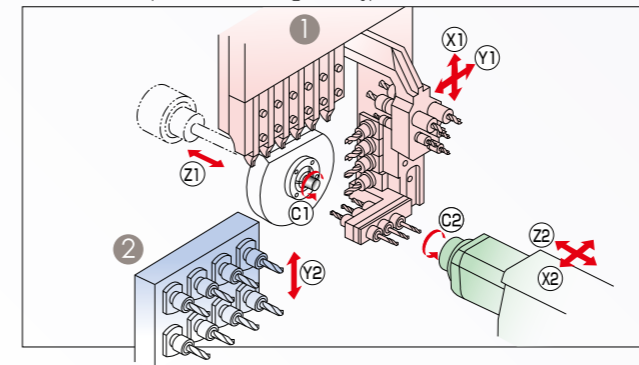

▼ Tool Post	
1	5-spindle cross drilling unit ER20
	Turning tool 6 tools
	Front-end working tool 5 tools
	Rear-end working tool 5 tools
	Power-driven tool 3 tools
	Cartridge type 2 Pos

▼ Tooling	
1	6-spindle cross drilling unit ER16
	Turning tool 6 tools
	Front-end working tool 5 tools
	Rear-end working tool 5 tools
	Power-driven tool 4 tools
	Cartridge type 2 Pos

▼ Tooling	
1	6-spindle cross drilling unit ER16
	Turning tool 6 tools
	Front-end working tool 5 tools
	Rear-end working tool 5 tools
	Power-driven tool 6 tools

▼ Tooling	
2	type B
	Rear-end working tool(Stationary/Power-driven) 8 tools
	type A
	Rear-end working tool(Stationary/Power-driven) 6 tools

■ Specifications

Item	Specifications
Max. machining diameter	φ 32mm(1-1/4in) OP: φ 34mm(1-11/32in)
Max. headstock stroke	Standard 320mm(12-19/32in) R.M.G.B. type 286.5mm(11-9/32in) N.G.B. type Bar diameter × 2.5(Max.80mm)(Max.3-5/32in)
Number of turning tools	6 tools
Tool shank	□ 16mm
5-spindle sleeve holder	Number of tools Front 5 tools Rear 5 tools
Max. drilling capability	φ 13mm(33/64in)
Max. tapping capability	M12 × P1.75
Number of tools	Cross milling 3 tools(ER20) + Cartridge type 2 positions Cross milling 4 tools(ER16) + Cartridge type 2 positions Cross milling 6 tools(ER16)
Power driven attachment	Max. drilling capability φ 10mm(25/64in) Max. tapping capability M8 × P1.25
Spindle speed	Cross milling : Max.6,000min ⁻¹ Cartridge-type tool : Max.8,000min ⁻¹
Drive motor	2.2kW(continuous) / 3.0kW(5min./30%ED)
Main spindle indexing angle	35m/min (X1, X2, Y1, Z1, Z2), 24m/min (Y2) ; type B only
Main spindle speed	C-axis control
Main spindle motor	Max.8,000min ⁻¹
Coolant tank capacity	275ℓ
Dimensions (W×D×H)	2,690 × 1,345 × 1,780mm
Weight	4,100kg

■ Backworking Attachment

Item	Specifications
Max. chucking diameter	φ 32mm(1-1/4in) OP: φ 34mm(1-11/32in)
Max. length for front ejection	125mm(4-59/64in)
Max. parts projection length	45mm(1-49/64in)
Number of tools	6 tools(type A) 8 tools(type B)
Unit especially for backworking	Max. drilling capability Stationary tool φ 13mm(33/64in) Power driven tool φ 8mm(5/16in) Max. tapping capability Stationary tool M10 × P1.5 Power driven tool M6 × P1.0
Spindle speed	Max.6,000min ⁻¹
Drive motor	1.0kW(continuous) / 1.2kW(5min./30%ED)
Sub spindle indexing angle	C-axis control
Sub spindle speed	Max.8,000min ⁻¹
Sub spindle motor	3.7kW(continuous) / 5.5kW(10min./40%ED)

Max. machining diameter is 38mm !
 Complex machining for extra large parts with high speed and universal control.

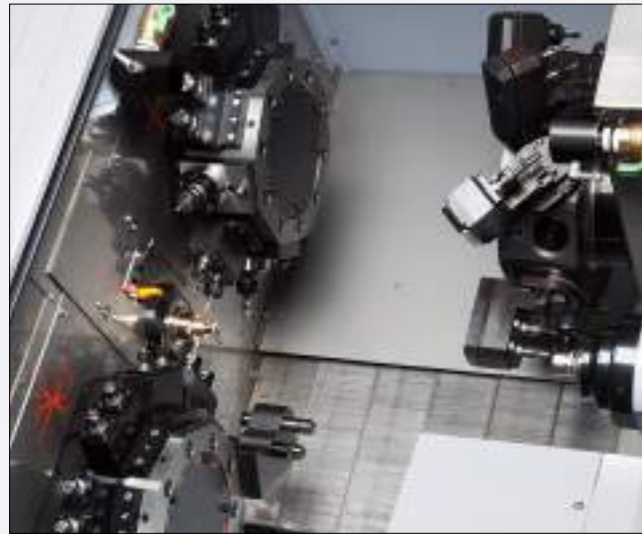

Three turrets allows ultra high speed and flexible machining of complicated components !

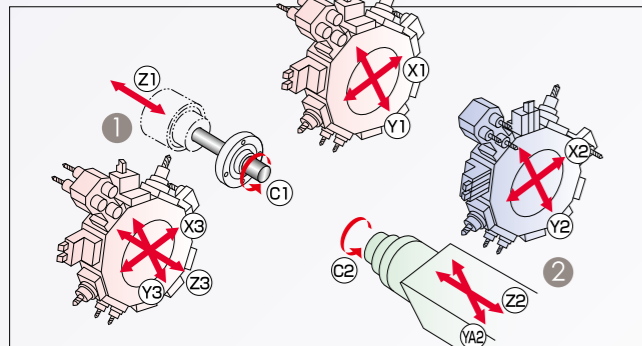

Specifications

Item	Specifications
Max. machining diameter	φ38mm (1-1/2in)
Max. headstock	Standard 350mm (13-25/32in)
stroke	R.M.G.B. type 315mm (12-13/32in):OP
Front turret	Near side turret 10 stations
tool post	Far side turret 10 stations
Number of turning tools	Number of tools 1 tool/station (□20mm), max. 2 tools/station (□16mm)
	Tool shank □20mm / □16mm
Sleeve holder	Number of tools max. 3 tools/station
	Max. drilling capability φ23mm (29/32in)
Power driven attachment	Max. tapping capability M16×P1.25
	Number of tools max. 2 tools/station
Drive motor	Max. drilling capability φ10mm (25/64in)
	Max. tapping capability M8×P1.25
Main spindle indexing angle	Spindle speed max.5,700min ⁻¹
	Drive motor 2.7kW(continuous)/4.0kW(5min./30%ED)
Main spindle speed	C-axis control max.7,000min ⁻¹
Main spindle motor	7.5kW(continuous)/11kW(10min./25%ED)
Dimensions (W×D×H)	3,477×1,859×1,865mm
Weight	6,250kg

Backworking Attachment

Item	Specifications
Max. chucking diameter	φ38mm (1-1/2in)
Max. part pick-up length	150mm (5-7/8in)
Max. parts projection length	75mm (2-61/64in)
Back turret tool post	10 station
Number of turning tools	1 tool/station (□20mm), max. 2 tools/station (□16mm)
	Tool shank □20mm / □16mm
Sleeve holder	Number of tools max. 3 tools/station
	Max. drilling capability φ23mm (29/32in)
Power driven attachment	Max. tapping capability M12×P1.75
	Number of tools max. 2 tools/station
Drive motor	Max. drilling capability φ10mm (25/64in)
	Max. tapping capability M8×P1.25
Sub spindle indexing angle	Spindle speed max.5,700min ⁻¹
	Drive motor 2.7kW(continuous)/4.0kW(5min./30%ED)
Sub spindle speed	C-axis control max.7,000min ⁻¹
Sub spindle motor	5.5kW(continuous)/7.5kW(10min./40%ED)

Tool Post

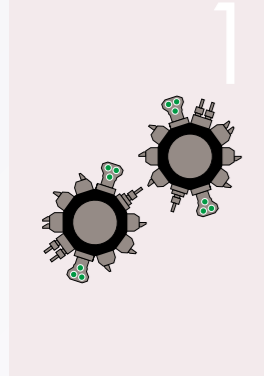

Tooling

Turning tool(□20mm)	1 tool /station
Turning tool(□16mm)	max.2 tools/station
Front-end working tool	max.3 tools/station
Rear-end working tool	max.3 tools/station
Power-driven tool	max.2 tools/station

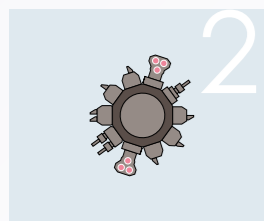

Turning tool(□20mm)	1 tool /station
Turning tool(□16mm)	max.2 tools/station
Rear-end working tool	max.3 tools/station
Power-driven tool	max.2 tools/station

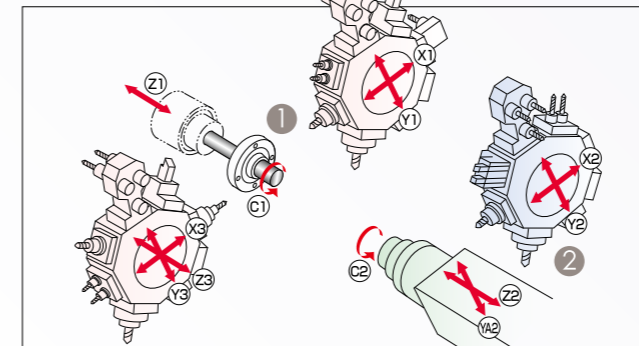

Specifications

Item	Specifications
Max. machining diameter	φ20mm (25/32in)
Max. headstock	Standard 350mm (13-25/32in)
stroke	R.M.G.B. type 317mm (12-31/64in):OP
Front working turret	Front side turret 8 stations
tool post	Back side turret 8 stations
Number of turning tools	Number of tools 1 tool/station (□16mm), max. 3 tools/station (□12mm)
	Tool shank □16mm/□12mm
Sleeve holder	Number of tools max. 3 tools/station
	Max. drilling capability φ14mm (35/64in)
Power driven attachment	Max. tapping capability M12×P1.75
	Number of tools max. 2 tools/station
Drive motor	Max. drilling capability φ10mm (25/64in)
	Max. tapping capability M8×P1.25
Main spindle indexing angle	Spindle speed max.5,750min ⁻¹
	Drive motor 2.5kW
Main spindle speed	C-axis control max.10,000min ⁻¹
Main spindle motor	3.7kW(Continuous)/5.5kW(10min./60%ED)
Dimension (W×D×H)	2,988×1,720×1,845mm
Weight	4,850kg

Tool Post

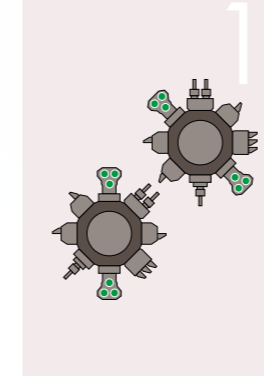

Tooling

Turning tool(□16mm)	1 tool/station
Turning tool(□12mm)	max.3 tools/station
Front-end working tool	max.3 tools/station
Rear-end working tool	max.3 tools/station
Power-driven tool	max.2 tools/station

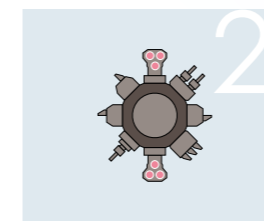

Turning tool(□16mm)	1 tool/station
Turning tool(□12mm)	max.3 tools/station
Rear-end working tool	max.3 tools/station
Power-driven tool	max.2 tools/station

Backworking Attachment

Item	Specifications
Max. chucking diameter	φ20mm (25/32in)
Max. part pick-up length	150mm (5-7/8in)
Max. parts projection length	75mm (2-61/64in)
Back turret tool post	8 stations
Number of turning tools	1 tool/station (□16mm), max. 3 tools/station (□12mm)
	Tool shank □16mm/□12mm
Sleeve holder	Number of tools max. 3 tools/station
	Max. drilling capability φ14mm (35/64in)
Power driven attachment	Max. tapping capability M12×P1.75
	Number of tools max. 2 tools/station
Drive motor	Max. drilling capability φ10mm (25/64in)
	Max. tapping capability M8×P1.25
Sub spindle indexing angle	Spindle speed max.5,750min ⁻¹
	Drive motor 2.5kW
Sub spindle speed	C-axis control max.10,000min ⁻¹
Sub spindle motor	3.7kW(Continuous)/5.5kW(10min./60%ED)

The latest model is of the highest quality in all aspects of the 38-dia. class.

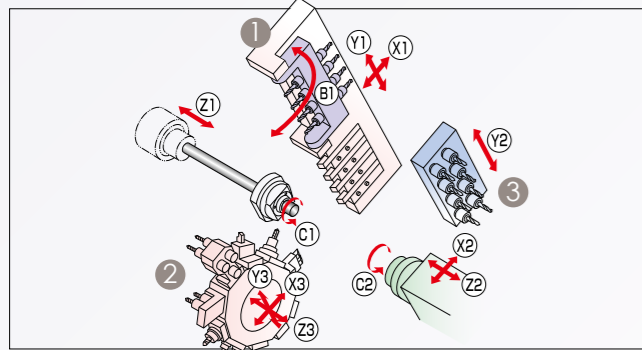
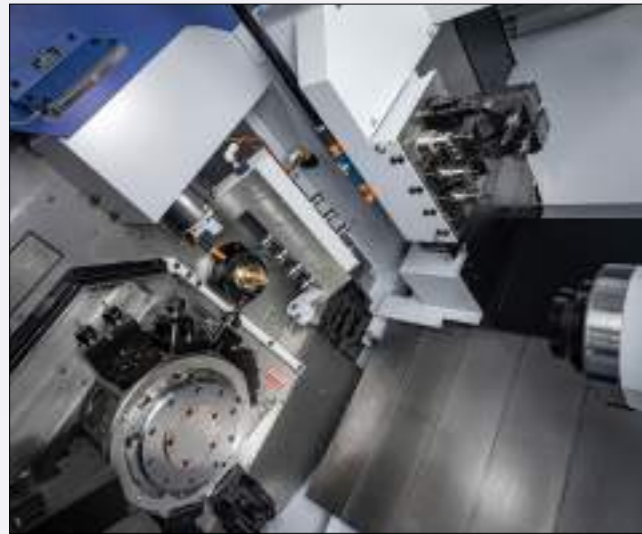

▼ Tool Post	▼ Tooling
1	Turning tool(□16mm) 3 tools Turning tool(□20mm) 1 tool Front-end power-driven tool(ER20) 4 tools Rear-end power-driven tool(ER16) 4 tools

2	Turning tool(□20mm) 1 tool/station Turning tool(□16mm) max.2 tools/station Front-end working tool max.3 tools/station Rear-end working tool max.3 tools/station Power-driven tool max.2 tools/station
---	---

3	Rear-end working tool 8 tools (Stationary tool/Power-driven tool)
---	--

Specifications

Item	Specifications
Max. machining diameter	φ38mm(1-1/2in)
Max. Standard	320mm(12-19/32in)
Max. headstock stroke	R.M.G.B. type 289mm(11-3/8in) : OP N.G.B. type 95mm(3-47/64in)
Tool post configuration	Gang type Turning tool + Power-driven tool Turret type 10 stations
Tool	Number of Gang type 4 tools Turret type Max.2tools / station
Sleeve	Number of tools Max.3tools / station Max. drilling capability φ23mm(29/32in) Max. tapping capability M16×P2.0
Power driven attachment	Number of Gang type B-axis controlled power-driven tool unit (Front : 4 tools, rear : 4 tools) Turret type Max.2tools / station Max. drilling capability Gang type φ10mm(25/64in) Turret type φ10mm(25/64in) Max. tapping capability Gang type M8×P1.25 Turret type M8×P1.25 Spindle Gang type Max.6,000min ⁻¹ Turret type Max.5,700min ⁻¹ Drive Gang type 2.2kW(continuous) / 3.0kW(5min. / 30%ED) Turret type 2.7kW(continuous) / 4.0kW(5min. / 30%ED)
Main spindle indexing angle	C-axis control
Main spindle speed	Max.7,000min ⁻¹
Main spindle motor	7.5kW(continuous) / 11kW(10min. / 25%ED)
Dimensions (W×D×H)	2,955×1,430×1,975mm

Backworking Attachment

Item	Specifications
Max. chucking diameter	φ38mm(1-1/2in)
Max. length for front ejection	150mm(5-7/8in)
Max. parts projection length	75mm(2-61/64in)
Number of tools	Stationary tool Max.8 tools Power driven tool Max.8 tools
Back 8-Spindle unit	Max. drilling capability Stationary tool φ23mm(29/32in) Power driven tool φ10mm(25/64in) Max. tapping capability Stationary tool M16×P2.0 Power driven tool M8×P1.25
Sub spindle indexing angle	C-axis control
Sub spindle speed	Max.7,000min ⁻¹
Sub spindle motor	7.5kW(continuous)/11kW(10min./25%ED)

Gang edge + 8-position turret + Backworking tool post

The above composition of the tool post reassures enhanced scalability for complex machining with adequate number of tools.

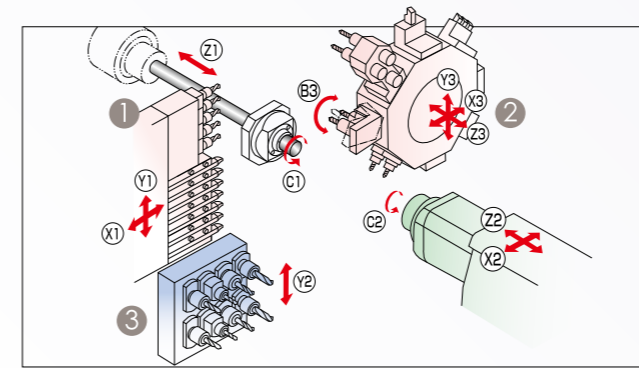

▼ Tool Post	▼ Tooling
1	Turning tool(□16mm) 6 tools Turning tool(□12mm) 7 tools Power-driven tool 5 tools

2	Turning tool(□16mm) 1 tool/station Turning tool(□12mm) max.3 tools/station Front-end working tool max.3 tools/station Rear-end working tool max.3 tools/station Power-driven tool max.2 tools/station
---	---

3	Rear-end working tool 8 tools (Stationary tool/Power-driven tool)
---	--

Specifications

Item	Specifications
Max. machining diameter	φ20mm (25/32in)
Max. Standard	205mm (8in)
Max. headstock stroke	R.M.G.B. type 160mm (6-19/64in):OP N.G.B. type Bar diameter×2.5 (max.50mm) (max.1-31/32in)
Tool post configuration	Gang type Turning tool + Power-driven tool Turret type 8 stations
Turning tool	Number of Gang type 6 tools (□16mm), 7 tools (□12mm) Turret type 1 tool/station (□16mm), max. 3 tools/station (□12mm)
Sleeve holder	Number of tools max. 3 tools/station Max. drilling capability φ14mm (35/64in) Max. tapping capability M12×P1.75
Power driven attachment	Number of Gang type 5 tools Turret type max. 2 tools/station(mountable at each 8 positions) Max. drilling capability Gang type φ10mm (25/64in) Turret type φ10mm (25/64in) Max. tapping capability Gang type M8×P1.25 Turret type M8×P1.25 Spindle Gang type max.8,000min ⁻¹ Turret type max.5,750min ⁻¹ Drive Gang type 2.2kW Turret type 2.7kW(continuous)/4.0kW(5min./30%ED)
Main spindle indexing angle	C-axis control
Main spindle speed	max.10,000min ⁻¹
Main spindle motor	3.7kW(continuous)/5.5kW(10min./60%ED)
Dimension (W×D×H)	2,730×1,350×1,865mm
Weight	4,150kg

Backworking Attachment

Item	Specifications
Max. chucking diameter	φ20mm (25/32in)
Max. length for front ejection	105mm (4-9/64in)
Max. parts projection length	75mm (2-61/64in)
Number of tools	8 tools
8-spindle backworking unit	Max. drilling capability Stationary tool φ12mm (1/2in) Power driven tool φ6mm (15/64in) Max. tapping capability Stationary tool M10×P1.5 Power driven tool M5×P0.8
Sub spindle indexing angle	C-axis control
Sub spindle speed	max.10,000min ⁻¹
Sub spindle motor	2.2kW(continuous)/3.7kW(10min./40%ED)

The Pursuit of reduced idle times both mechanically and electrically through the latest software allow complex components to be manufactured in the fastest possible times to improve both production output & profitability.



The Latest SW Model Heading for the Highest capability in Machining of Small Diameter Workpieces.

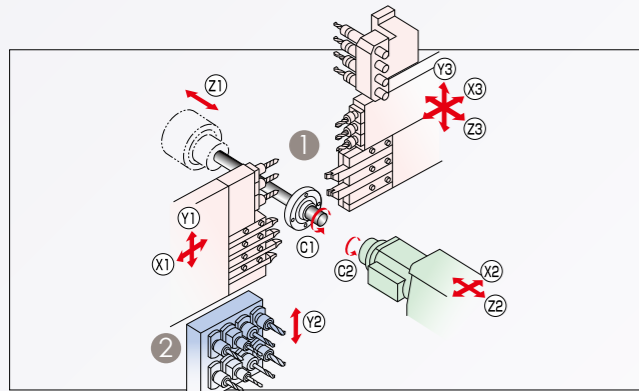
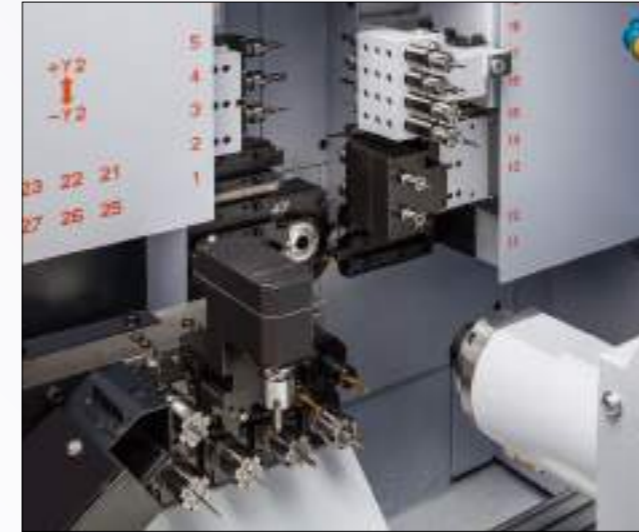

■ Specifications

Item	Specifications
Max. machining diameter	φ20mm (25/32in)
Max. headstock stroke	Standard 205mm (8in) R.M.G.B. type 175mm (6-57/64in):OP
Tool post configuration	Front Turning tool + Power-driven tool Rear Turning tool+4-spindle sleeve holder+Power-driven tool
Turning tool	Number of tools Front 4 tools (□20mm/□16mm) Rear 2 tools (□12mm/□16mm)
4-spindle sleeve holder	Number of tools Front 4 tools Rear 4 tools
	Max. drilling capability φ10mm (25/64in) Max. tapping capability M8×P1.25
Power driven attachment	Number of tools Front 3pos. Rear 3pos.
	Max. drilling capability φ8mm (5/16in) Max. tapping capability M6×P1.0 Spindle speed max.8,000min ⁻¹ Drive motor 1.0kW(continuous)/1.2kW(5min./30%ED)
Main spindle indexing angle	C-axis control
Main spindle speed	max.10,000min ⁻¹
Main spindle motor	2.2kW(continuous)/3.7kW(10min./25%ED)
Dimension (W×D×H)	2,588×1,150×1,765mm
Weight	3,400kg

▼ Tool Post

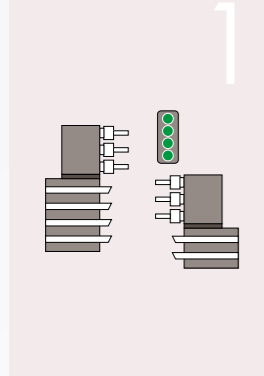

▼ Tooling

Turning tool	6 tools
Front-end working tool	4 tools
Rear-end working tool	4 tools
Power-driven tool	6 tools

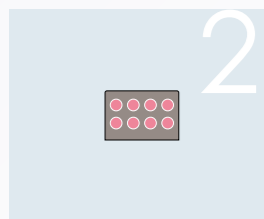

Rear-end working tool (Stationary tool / Power-driven tool)	8 tools (max. 8 tools / max. 6 tools)
---	---------------------------------------

■ Backworking Attachment

Item	Specifications
Max. chucking diameter	φ20mm (25/32in)
Max. length for front ejection	80mm (3-5/32in)
Max. parts projection length	30mm (1-3/16in)
8-spindle backworking unit	Number of tools 8 tools
	Max. drilling Stationary tool φ10mm (25/64in) Power-driven tool φ8mm (5/16in)
	Max. tapping Stationary tool M8×P1.25 Power-driven tool M6×P1.0
Sub spindle indexing angle	C-axis control
Sub spindle speed	max.10,000min ⁻¹
Sub spindle motor	2.2kW(continuous)/3.7kW(10min./25%ED)

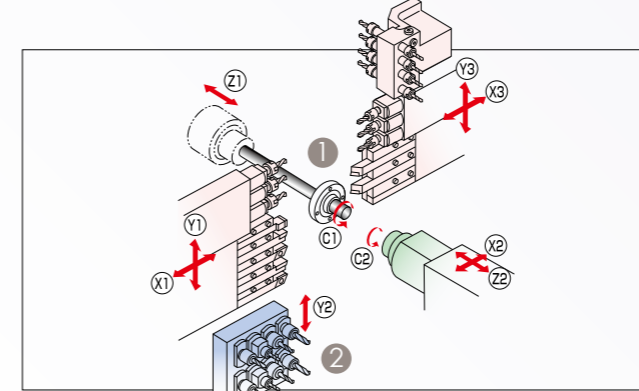

■ Specifications

Item	Specifications
Max. machining diameter	φ13mm (33/64in)
Max. headstock stroke	Standard 135mm (5-5/16in) R.M.G.B. type 95mm (3-47/64in):OP
Tool post configuration	Front Turning tool + Power-driven tool Rear Turning tool+4-spindle sleeve holder+Power-driven tool
Turning tool	Number of tools Front 5 tools (□10mm) Rear 2 tools (□10mm)
4-spindle sleeve holder	Number of tools Front 4 tools Rear 4 tools
	Max. drilling capability φ8mm (5/16in) Max. tapping capability M8×P1.25
Power driven attachment	Number of tools Front 3pos. Rear 3pos.
	Max. drilling capability φ5mm (3/16in) Max. tapping capability M4×P0.7 Spindle speed max.12,000min ⁻¹ Drive motor 1.0kW(continuous)/1.2kW(5min./30%ED)
Main spindle indexing angle	C-axis control
Main spindle speed	max.15,000min ⁻¹
Main spindle motor	2.2kW(continuous)/3.7kW(10min./25%ED)
Dimension (W×D×H)	1,995×920×1,700mm
Weight	2,100kg

▼ Tool Post

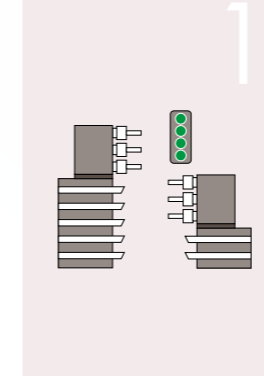

▼ Tooling

Turning tool	7 tools
Front-end working tool	4 tools
Rear-end working tool	4 tools
Power-driven tool	6 tools

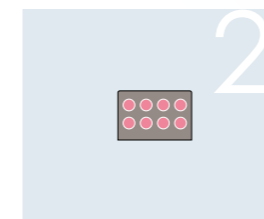

Rear-end working tool (Stationary tool / Power-driven tool)	8 tools
---	---------

■ Backworking Attachment

Item	Specifications
Max. chucking diameter	φ13mm (33/64in)
Max. length for front ejection	80mm (3-5/32in)
Max. parts projection length	20mm (25/32in)
8-spindle backworking unit	Number of tools 8 tools
	Max. drilling Stationary tool φ8mm (5/16in) Power-driven tool φ5mm (3/16in)
	Max. tapping Stationary tool M6×P1.0 Power-driven tool M4×P0.7
Sub spindle indexing angle	C-axis control
Sub spindle speed	max.15,000min ⁻¹
Sub spindle motor	2.2kW(continuous)/3.7kW(10min./40%ED)

Complex Machines for Large-Diameter Workpieces
Now Aim for Higher Functionality, Productivity and Accuracy

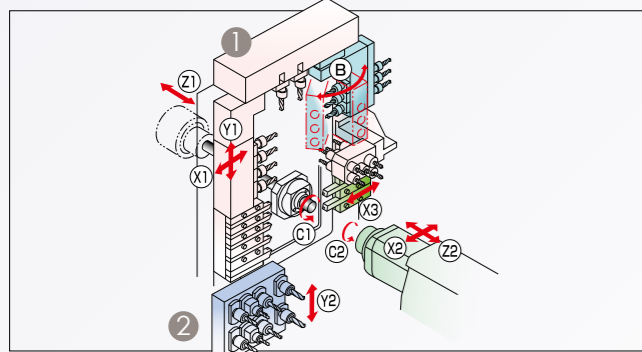
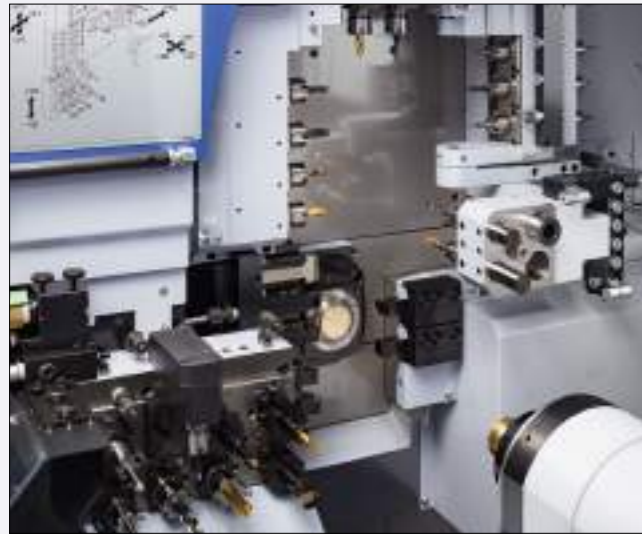

Specifications

Item	Specifications
Max. machining diameter	φ38mm(1-1/2in)
Max. headstock stroke	Standard 320mm(12-19/32in)
	R.M.G.B. type 288mm(11 1/32in) : OP
	N.G.B. type Bar diameter×2.5(max.95mm)(max.3-47/64in)
Number of turning tools	Number of tools 5 tools on the front(stationary type)+2 tools on the rear(X3 axis control)
	Tool shank □20mm(T100)/□16mm
5-spindle sleeve holder	Number of tools Front 5 tools Rear 5 tools
	Max. drilling capability φ23mm(29/32in)
	Max. tapping capability M16×P2.0
Power driven attachment	Cross milling : 4 tools
	Number of tools Cartridge type : At 2 position B-axis controlled power-driven tool unit : At 1 position (Front 3 tools+Rear 3 tools)
	Max. drilling capability φ10mm(25/64in)
	Max. tapping capability M8×P1.25
	Spindle speed max.6,000min ⁻¹
Drive motor 2.2kW(continuous) / 3.0kW(5min./30%ED)	
Main spindle indexing angle	C-axis control
Main spindle speed	max.7,000min ⁻¹
Main spindle motor	7.5kW(continuous) / 11kW(10min./25%ED)
Dimensions (W×D×H)	2,740×1,315×2,120mm
Weight	4,300kg

Tool Post

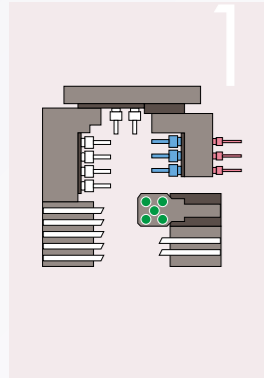

Tooling

Turning tool	7 tools
Front-end working tool	5 tools
Rear-end working tool	5 tools
Power-driven tool	4 tools
Cartridge type	2Pos
B-axis controlled power-driven tool unit	1Pos (Front 3 tools+Rear 3 tools)

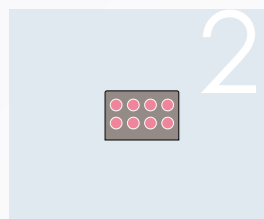

Rear-end working tool	8 tools (Stationary tool/Power-driven tool)
-----------------------	--

Backworking Attachment

Item	Specifications
Max. chucking diameter	φ38mm(1-1/2in)
Max. length for front ejection	150mm(5-7/8in)
Max. parts projection length	70mm(2-3/4in)
8-spindle backworking unit	Number of tools 8 tools
	Max. drilling Stationary tool φ14mm(35/64in)
	Power driven tool φ8 mm(5/16in)
Max. tapping capability	Stationary tool M12×P1.75
	Power driven tool M6×P1.0
Sub spindle indexing angle	C-axis control
Sub spindle speed	max.7,000min ⁻¹
Sub spindle motor	3.7kW(continuous)/5.5kW(10min./40%ED)

CNC SWISS TYPE AUTOMATIC LATHE

Complex machining functions adaptable to multiple industries.



Photo: SR-20RV type B



Illustration: SR-20RV type B

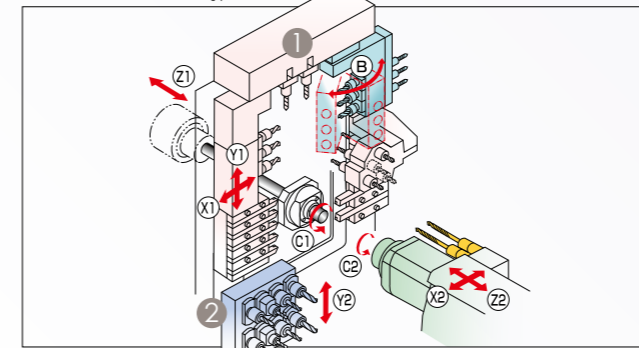

Tool Post

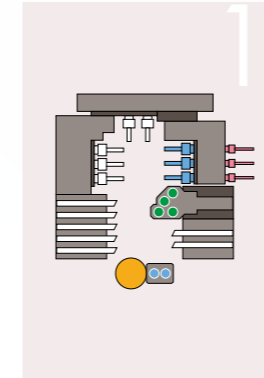

Tooling

Turning tool	7 tools
Front-end working tool	6 tools
Rear-end working tool	4 tools
Power-driven tool	3 tools
Cartridge type	2Pos
[type A]	
Angle adjustable power-driven tool	1Pos (Front 3 tools+Rear 3 tools)
[type B]	
B-axis controlled power-driven tool unit	1Pos (Front 3 tools+Rear 3 tools)

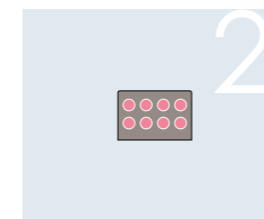

Rear-end working tool	8 tools (Stationary tool/Power-driven tool)
-----------------------	--

Specifications

Item	Specifications
Max. machining diameter	φ20mm (25/32in)
Max. headstock stroke	Standard 205mm (8in)
	R.M.G.B. type 160mm (6-19/64in):OP
	N.G.B. type Bar diameter×2.5 (max.50mm) (max.1-31/32in)
Number of turning tools	Number of tools 5 tools on the front + 2 tools on the rear
	Tool shank □12mm
4-spindle sleeve holder	Number of tools Front 4 tools Rear 4 tools
	Max. drilling capability φ12mm (1/2in)
	Max. tapping capability M10×P1.5
2-spindle front sleeve holder	Number of tools(sleeve) 2 tools
	Max. drilling capability φ10mm (25/64in)
	Max. depth of hole 100mm (3-15/16in)
Power driven attachment	Cross milling : 3 tools
	Number of tools Cartridge type : At 2 position
	Number of tools [type A] Angle adjustable power-driven tool : At 1 position (Front 3 tools+Rear 3 tools)
	Number of tools [type B] B-axis controlled power-driven tool unit : At 1 position (Front 3 tools+Rear 3 tools)
	Max. drilling capability φ10mm (25/64in)
Max. tapping capability	M8×P1.25
Spindle speed	max.8,000min ⁻¹
Drive motor	2.2kW
Main spindle indexing angle	C-axis control
Main spindle speed	max.10,000min ⁻¹
Main spindle motor	2.2kW(continuous)/3.7kW(10min./25%ED)
Dimensions (W×D×H)	2,334×1,200×1,700mm
Weight	2,600kg

Backworking Attachment

Item	Specifications
Max. chucking diameter	φ20mm (25/32in)
Max. length for front ejection	80mm (3-5/32in)
Max. parts projection length	30mm (1-3/16in)
8-spindle backworking unit	Number of tools 8 tools
	Max. drilling Stationary tool φ12mm (1/2in)
	Power driven tool φ6mm (15/64in)
Max. tapping capability	Stationary tool M10×P1.5
	Power driven tool M5×P0.8
Sub spindle indexing angle	C-axis control
Sub spindle speed	max.10,000min ⁻¹
Sub spindle motor	2.2kW(continuous)/3.7kW(10min./25%ED)

SR-20JII type B

SR-20JII type A

Ever-Evolving SR-20JII with Versatile Features to Respond to Varied Needs



Photo: SR-20JII type B



Illustration: Type B

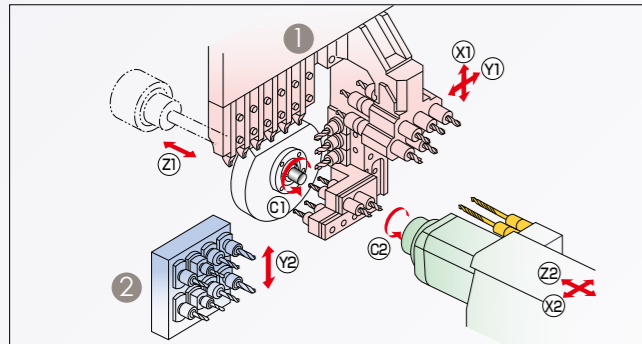

Specifications

Item	Specifications
Max. machining diameter	φ20mm(25/32in) Standard 205mm(8in)
Max. headstock stroke	R.M.G.B. type 160mm(6-19/64in) N.G.B. type Bar diameter×2.5 (max.50mm)(max.1-31/32)
Number of tools	6 tools
Tool shank	□12mm
5-spindle sleeve holder	Number of tools Front 5 tools Rear 5 tools
	Max. drilling capability φ12mm(1/2in) Max. tapping capability M10×P1.5
2-spindle front sleeve holder	Number of tools 2 tools
	Max. drilling capability φ10mm(25/64in) Max. depth of hole 100mm(3-15/16in)
	Number of tools Cross milling: 3 tools (ER16) + Cartridge type 2 Pos Cross milling: 3 tools (ER20×1, ER16×2) + Cartridge type 2 Pos
Power driven attachment	Max. drilling capability φ10mm (25/64in) Max. tapping capability M8×P1.25 Spindle speed max.8,000min ⁻¹ Drive motor 2.2kW
Main spindle indexing angle	C-axis control
Main spindle speed	max.10,000min ⁻¹
Main spindle motor	2.2kW(continuous)/3.7kW(10min./25%ED)
Dimensions (W×D×H)	2,250×1,200×1,700mm
Weight	2,750kg

Backworking Attachment

Item	SR-20JII type B	SR-20JII type A
Max. chucking diameter	φ20mm(25/32in)	
Max. length for front ejection	100mm(3-15/16in)	
Max. parts projection length	30mm(1-3/16in)	
Number of tools	8 tools	4 tools
Unit especially for backworking	Max. drilling capability Stationary tool φ12mm(1/2in) Power-driven tool φ6mm(15/64in) Max. tapping capability Stationary tool M10×P1.5 Power-driven tool M5×P0.8	
Sub spindle indexing angle	C-axis control	
Sub spindle speed	max.10,000min ⁻¹	
Sub spindle motor	2.2kW(continuous)/3.7kW(10min./25%ED)	

Tool Post

5-spindle cross drilling unit ER16

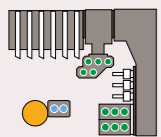

Tooling

Turning tool	6 tools
Front-end working tool	7 tools
Rear-end working tool	5 tools
Power-driven tool (ER16)	3 tools
Cartridge type	2 Pos

5-spindle cross drilling unit ER16/20

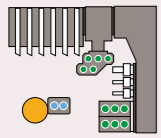

Turning tool	6 tools
Front-end working tool	7 tools
Rear-end working tool	5 tools
Power-driven tool (ER20)	1 tool
Power-driven tool (ER16)	2 tools
Cartridge type	2 Pos

type B



2

type B	Rear-end working tool 8 tools (Stationary tool/Power-driven tool)
type A	Rear-end working tool 4 tools (Stationary tool/Power-driven tool)

type A



SR-10J type C

With improved secondary machining capability and operability, the evolutionary advanced SR-10J is now on the market.



Specifications

Item	Specifications
Max. machining diameter	φ10mm (25/64in)
Max. headstock stroke	Stationary G.B. type 135mm (5-5/16in) R.G.B. type 105mm (4-9/64in) R.M.G.B. type 75mm (2-61/64in):OP
Number of turning tools	Number of tools 6 tools Tool shank □8mm
4-spindle sleeve holder	Number of tools Front 4 tools Rear 4 tools
	Max. drilling capability φ6mm (15/64in) Max. tapping capability M5×P0.8
Power driven attachment	Number of tools 3 tools
	Max. drilling capability φ4mm (5/32in) Max. tapping capability M3×P0.5 Spindle speed max.10,000min ⁻¹ Drive motor 0.5kW
Main spindle indexing angle	C-axis control
Main spindle speed	max.15,000min ⁻¹
Main spindle motor	2.2kW(Continuous)/3.7kW(15min./60%ED)
Dimension (W×D×H)	1,865×775×1,695mm
Weight	1,400kg

Backworking Attachment

Item	Specifications
Max. chucking diameter	φ10mm (25/64in)
Max. length for front ejection	70mm (2-3/4in)
Max. parts projection length	20mm (25/32in)
Number of tools	4 tools
4-spindle backworking unit	Max. drilling capability Stationary tool φ4mm (5/32in) Power-driven tool φ4mm (5/32in) Max. tapping capability Stationary tool M3×P0.5 Power-driven tool M3×P0.5
Sub spindle indexing angle	C-axis control
Sub spindle speed	max.10,000min ⁻¹
Sub spindle motor	0.55kW(Continuous)/1.1kW(15min./50%ED)

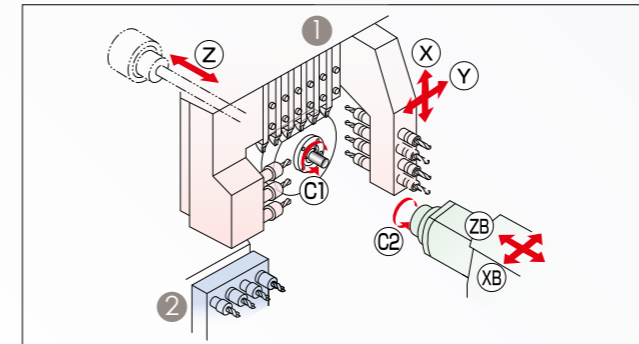

Tool Post

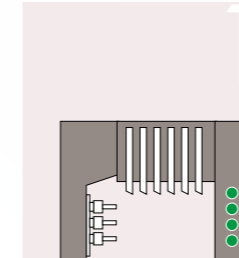

Tooling

Turning tool	6 tools
Front-end working tool	4 tools
Rear-end working tool	4 tools
Power-driven tool	3 tools

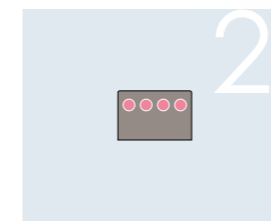

Rear-end working tool (Stationary tool)	4 tools
(Power-driven tool)	max. 4 tools
(Power-driven tool)	max. 2 tools

By selecting a G.B. type, tool post and tool unit and arranging them according to the machining process it enables many different kind of machining option.



Photo: type G / (Cartridge type 5-spindle cross drilling unit)/N.G.B.type

type G

- * SB-12R type G : [Max. machining diameter]
- ** SB-16R type G : [Max. machining diameter]
- ** SB-20R type G : [Max. machining diameter]
- * SB-12R type G : [Max. machining diameter]
- ** SB-16R/20R type G : [Max. machining diameter]

□ A Variety of Tooling Layouts of Cartridge-Type Cross Drilling Units

Basic model

Turning tool (6 tools / 7 tools)
 Power-driven tools (2-spindles) designed for cross drilling

Cartridge-type (3Pos.)

Milling unit / Front drilling unit / Special power-driven unit
 Sleeve holder

Front/rear power-driven tools
 Front/rear stationary tools

Variation 01 **Variation 02** **Variation 03** **Variation 04** **Variation 05**

Variation 06 **Variation 07** **Variation 08** **Variation 09** **Variation 10**

Tool Post

4-Spindle cross drilling unit

Turning tool (□12mm) 6 tools
 Turning tool (□10mm) 7 tools
 Front-end working tool 4 tools
 Rear-end working tool 4 tools
 Power-driven tool 4 tools

5-Spindle cross drilling unit

Turning tool (□12mm) 6 tools
 Turning tool (□10mm) 7 tools
 Front-end working tool 4 tools
 Rear-end working tool 4 tools
 Power-driven tool 5 tools

Cartridge type cross drilling unit
 5-Spindle / 5-Spindle high-speed

Turning tool (□12mm) 6 tools
 Turning tool (□10mm) 7 tools
 Power-driven tool 2 tools
 Cartridge type 3Pos

2

Rear-end working tool 4 tools
 (Stationary tool/Power-driven tool)

(type G / N)

Illustration: type G / (Cartridge type 5-spindle cross drilling unit)/N.G.B.type

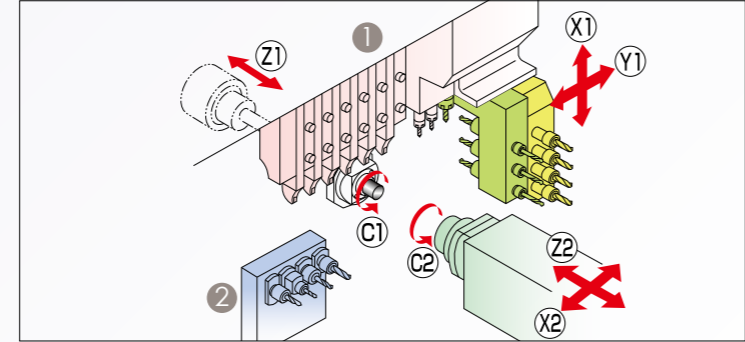

Type C

- * SB-16R type C : [Max. machining diameter]
- ** SB-20R type C : [Max. machining diameter]



Type N

■ Specifications

Item	4-Spindle Cross drilling unit			5-Spindle Cross drilling unit			Cartridge-type cross drilling unit											
	12R	16R	20R	12R	16R	20R	5-Spindle			5-Spindle high-speed								
Max. machining diameter	φ13mm(33/64in)	φ16mm(5/8in)	φ20mm(25/32in)	φ13mm(33/64in)	φ16mm(5/8in)	φ20mm(25/32in)	φ13mm(33/64in)	φ16mm(5/8in)	φ20mm(25/32in)	φ13mm(33/64in)	φ16mm(5/8in)	φ20mm(25/32in)						
Max. headstock stroke	Type C			205mm (8in)			Type G						205mm (8in)					
	Type G			12R : Bar diameter×2.5 (max.30mm) (max.1-3/16in)			16R/20R : Bar diameter×2.5 (max.50mm) (max.1-31/32in)						Type N			Bar diameter×2.5 (max.55mm) (max.2-11/64in)		
Number of turning tools	Type N			6 tools (□12mm)/7 tools (□10mm)			Front 4 tools						Rear 4 tools					
4-spindle sleeve holder	Number of tools			Front 4 tools			Rear 4 tools						12R : φ10mm (25/64in) 16R/20R : φ12mm (1/2in)					
	Max. drilling capability			12R : φ10mm (25/64in) 16R/20R : φ12mm (1/2in)			M10×P1.5											
	Max. tapping capability			M10×P1.5														
Power driven attachment	Number of tools			Cross power driven att. 4 tools (ER16)			Cross power driven att. 5 tools (ER11)			Cross power driven att. 2 tools (ER11)								
	Max. drilling capability			ER16 φ7mm (9/32in)			ER11 φ5mm (3/16in)			φ6mm (15/64in)			φ7mm (9/32in)					
	Max. tapping capability			ER16 M6×P1.0			ER11 φ5mm (3/16in)			M5×P0.8			M6×P1.0					
	Spindle speed			ER16 max.6,000min ⁻¹			ER11 max.10,000min ⁻¹			max.8,000min ⁻¹			max.6,000min ⁻¹					
	Drive motor			1.0kW(continuous)/1.2kW(5min./30%ED)			C-axis control											
	Main spindle indexing angle			C-axis control														
	Main spindle speed			12R : max.15,000min ⁻¹ , 16R/20R : max.10,000min ⁻¹														
	Main spindle motor			2.2kW(continuous)/3.7kW(10min./25%ED)														
	Dimensions (W×D×H)			2,070×1,177×1,760mm														
	Weight			1.650kg (type C), 1.750kg (type G), 1.700kg (type N)														

■ Backworking Attachment

Item	Type C		Type G			Type N
	16R	20R	12R	16R	20R	20R
Max. chucking diameter	φ16mm(5/8in)	φ20mm(25/32in)	φ13mm(33/64in)	φ16mm(5/8in)	φ20mm(25/32in)	φ20mm(25/32in)
Max. length for front ejection	80mm (3-5/32in)		80mm (3-5/32in)			
Max. parts projection length	30mm (1-3/16in)		30mm (1-3/16in)			
Number of tools	—		4 tools			
4-spindle backworking capability	Max drilling Stationary tool		φ8mm (5/16in)			
	Power driven tool		φ6mm (15/64in)			
unit	Max tapping Stationary tool		M6×P1.0			
	Power driven tool		M5×P0.8			
Sub spindle indexing angle	—		C-axis control			
Sub spindle speed	max.8,000min ⁻¹		max.12,000min ⁻¹		max.9,000min ⁻¹	
Sub spindle motor	1.0kW		0.55kW(continuous)/1.1kW(15min./40%ED)			

Star Micronics Enters Its New Territory With the Fixed-Headstock Lathes.

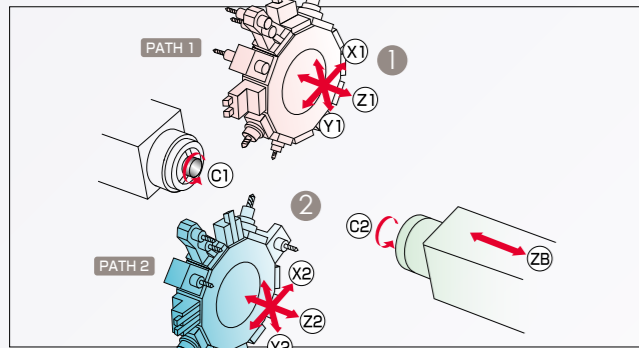
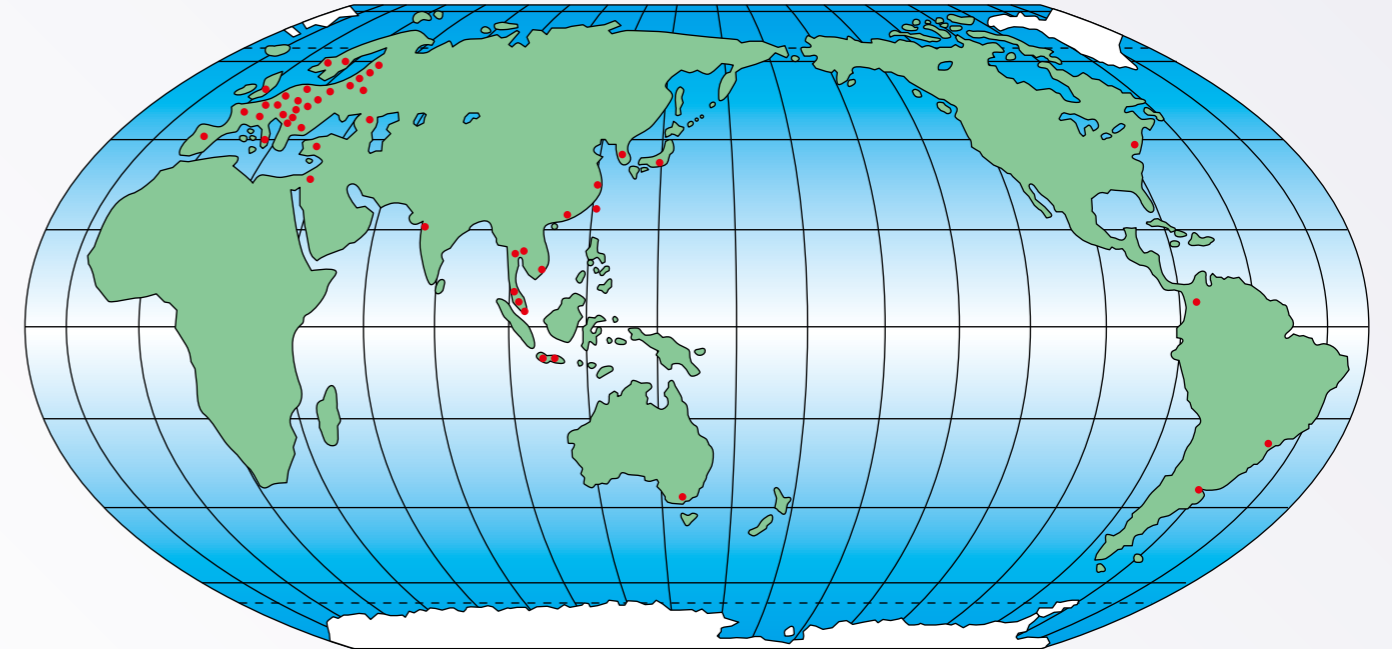

Specifications

Item	Specifications		
Main spindle	Max. machining diameter	φ51mm(2in)	
	Max. machining length	125mm(4-59/64in)	
	Main spindle indexing angle	C-axis control	
	Main spindle speed	max.5,000min ⁻¹	
	Main spindle motor	7.5kW(continuous)/15kW(1.0min./15%ED)	
	Through-spindle hole diameter	φ52.5mm(2-1/16in)	
Sub spindle	Chuck type	Hydraulic rotary cylinder	
	Max. machining diameter	φ51mm(2in)	
	Max. length for front ejection	125mm(4-59/64in)	
	Max. parts projection length	80mm(3-5/32in)	
	Main spindle indexing angle	C-axis control	
	Main spindle speed	max.5,000min ⁻¹	
Tool post	Main spindle motor	7.5kW(continuous)/15kW(1.0min./15%ED)	
	Through-spindle hole diameter	φ52.5mm(2-1/16in)	
	Chuck type	Hydraulic rotary cylinder	
	Type	12-stationed turret	
	Number of tools	□20mm(25/32in) max. 2 tools/station	
	Number of sleeves	max. 2 sleeves/station	
PATH 1	Power driven tool	max. 2 tools/station	
	Spindle speed	max.6,000min ⁻¹	
	Power driven tool	Drive motor	4.5kW(continuous)/7.5kW(5min./30%ED)
		Max. drilling capability	φ 16mm(5/8in)
		Max. tapping capability	M12×P1.75
	Milling		φ 20mm(25/32in)
Type		12-stationed turret	
Number of tools		□20mm(25/32in) max. 2 tools/station	
PATH 2	Number of sleeves	max. 2 sleeves/station	
	Power driven tool	max. 2 tools/station	
	Spindle speed	max.6,000min ⁻¹	
	Power driven tool	Drive motor	4.5kW(continuous)/7.5kW(5min./30%ED)
		Max. drilling capability	φ 16mm(5/8in)
		Max. tapping capability	M12×P1.75
Milling		φ 20mm(25/32in)	
	Dimensions (W×D×H)	2,800×2,070×2,130mm	
Weight	6,600kg		

Tool Post

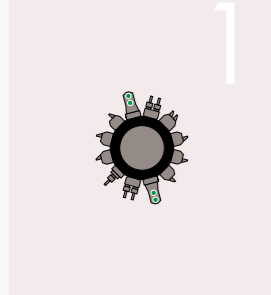

Tooling

Turning tool(□20mm)	max.2 tools/station
Front-end working tool	max.2 tools/station
Rear-end working tool	max.2 tools/station
Power-driven tool	max.2 tools/station

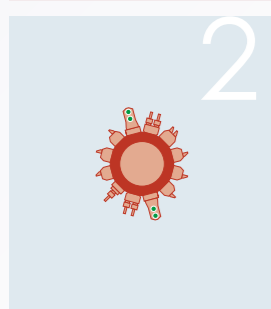

Turning tool(□20mm)	max.2 tools/station
Front-end working tool	max.2 tools/station
Rear-end working tool	max.2 tools/station
Power-driven tool	max.2 tools/station

ARGENTINA	HISUCOM S.R.L.
AUSTRALIA	HS CNC MACHINES PTY. LTD.
AUSTRIA	HELMER WERKZEUGMASCHINEN MARA WERKZEUGPRODUKTION GMBH
BELARUS	ALFLETH ENGINEERING AG
BELGIUM	OUDE REIMER BV
BRAZIL	STAR TECH CENTER DO BRASIL
BULGARIA	ALFLETH ENGINEERING AG
		BULMAKMETAL LTD
		SHANGHAI XINGANG MACHINERY CO., LTD.
CHINA	IMOCOM S.A.
COLOMBIA	ALFLETH ENGINEERING S.R.O
CZECH REPUBLIC	FLEXTEK A/S
DENMARK	STAR MACHINE TOOL FRANCE
FRANCE	STAR MICRONICS GMBH
GERMANY	VIRAG HIGHTECH CNC KFT.
HUNGARY	COSMOS IMPEX (INDIA) PVT. LTD.
INDIA	PT. JAYA METAL TEKNIKA
INDONESIA	PT. MARUKA INDONESIA
		TEKTEAM LTD.
ISRAEL	R. F. CELADA SPA
ITALY	STAR KOREA TRADING CO., LTD.
KOREA	OUDE REIMER BV
LUXEMBOURG	CK MAC SDN.BHD
MALAYSIA	SAEILO JAPAN (M) SDN. BHD.
		OUDE REIMER BV
		CNC SERVICES LIMITED
NETHERLANDS	RANDS LTD.
NEW ZEALAND	ALFLETH ENGINEERING AG
POLAND	ALFLETH ENGINEERING SPOL S.R.O.
RUSSIA	ALFLETH ENGINEERING D.O.O
SLOVAK REPUBLIC	MACHINE TERMINAL SDN. BHD.
SLOVENIA	SAEILO TECHNOLOGIES PTE LTD.
SINGAPORE	DAUNERT SA
		LENIMA MACHINE TOOL AB
SPAIN	STAR MICRONICS AG.
SWEDEN	KENUC PRECISION MACHINERY CO., LTD.
SWITZERLAND	STAR MICRONICS (THAILAND) CO., LTD.
TAIWAN	SAEILO (THAILAND) CO., LTD.
THAILAND	STAR TURKEY CNC MAKINA SAN. TIC. LTD. STI.
		STAR MICRONICS GB LIMITED
TURKEY	STAR CNC MACHINE TOOL CORPORATION
UNITED KINGDOM	KAMOGAWA (VIETNAM) CO., LTD.
U.S.A.	
VIETNAM	